

1986



Cobalt Boats

OWNERS MANUAL

1 9 8 6 C O B A L T

Welcome to the world of Cobalt and its family of proud owners.

The name, Cobalt, has become the symbol of excellence in the world of boating. Behind this name are the creators and makers who believe quality and owner satisfaction are unquestionably the most important parts of every boat we build.

No other boat is more respected for styling, comfort, convenience and attention to detail. Your concern for proper operation, care and maintenance will provide you with many years of boating satisfaction.

This manual was prepared to acquaint you with the operation and maintenance of your Cobalt. We suggest you read this manual carefully and follow the recommendations to assure enjoyable and trouble-free operation.

It is also to your own personal advantage to become well acquainted with the rules and general "know how" of boating.

For service and assistance, remember to call upon your Cobalt dealer. He will be happy to assist you in matters concerning maintenance, warranty and any other questions you may have concerning your Cobalt.

TABLE OF CONTENTS

I. Equipment and Government Regulations	
1. Lights	4
2. Whistle or Horn	4
3. Fire Extinguisher	4
4. Life Saving Devices	4
5. Additional Recommendations	4
6. Inland Lakes	4
7. Intracoastal Waters	4
II. Boating Industry Associations Certification	5
III. Interior/Exterior Care	
1. Upholstery	6
2. Vacuuming	6
3. Carpet	6
4. Teakwood	7
5. Canvas	7
IV. Boat Operation	
1. Top	9
2. Top Stowage	10
3. Canvas Maintenance	11
4. Seat Adjustment	11
5. Cabin Access Doors	12
6. Instrument Panel	13
7. Engine Control	21
8. Steering System	21
9. Power Trim	22
10. Warning Labels	23
11. High Speed Operation	24
12. Lifting Rings	25
13. Trash Receptacle	25
14. Fold Down Ladder	26
15. Water Skiing	26
16. Deck Hatch	26
17. Engine Access	26
18. Dual Batteries and Switches (Twin Engine Only)	27
19. Optional Equipment	28
V. Propellers and Propeller Chart	30
VI. Technical Information	
1. Engine Operation/ Maintenance/Service	34
2. Break In	34
3. Winterizing and Storage	34
4. Fuel Requirements	35
5. Trouble Check Chart	35
6. Electrical System	38
7. Wiring Diagrams	38
8. Circuit Breakers	38
9. Light Bulbs	38
10. Specifications	48
11. Cobalt Warranty	49
VII. Service Record Pages	50

I. EQUIPMENT AND GOVERNMENT REGULATIONS

1. Lights

Motorboats under 26 feet in length underway between sunset and sunrise must display proper lights. A boat at anchor must display a white anchor light less than 20 feet over the hull and that must be visible for at least one mile to a boat approaching from any direction.

2. Whistle or Horn

All boats 16 feet to 26 feet in length (Class 1) are required to carry a horn or whistle which is audible at least one mile. It may be hand, mouth, or power operated.

3. Fire Extinguisher

All I/O boats up to 26 feet in length (Class A and Class 1) are required to carry at least one B-1 type approved and portable fire extinguisher. Your Cobalt is standard equipped to meet all of the above requirements.

4. Life Saving Devices

All boats must carry one Coast Guard approved type 1, 2, or 3, (wearable) device for every person on board. In addition, each boat over 16 feet in length is required to carry one approved type 4 throwable life saving device such as a ring life buoy or buoyant cushion. When the approval stamps are no longer legible and the equipment cannot otherwise be identified as being approved, the equipment must be replaced with currently approved equipment.

5. Additional Recommended Equipment

Although not required by law, the conscientious boatman will make sure that his boat is equipped with the following items:

1. Compass
2. Distress signal flares
3. Flashlight
4. First Aid Kit
5. Anchor and anchor line
6. Tool Kit
7. Paddle

6. Inland Lakes

All boats operating on inland lakes are under the jurisdiction of state governments. You should always check your local state laws for specified equipment necessary when navigating their waterways.

7. Intracoastal Waters

Regulations governing equipment necessary while operating in intracoastal waters are different than inland rules. Make sure you have the proper equipment on board. The best source for information is the U.S. Coast Guard.

II. BOATING INDUSTRY ASSOCIATIONS CERTIFICATION

Boating Industry Associations is a National Trade Association serving all elements of the Recreational Boating Industry.

Its members include manufacturers of all types of boating equipment — outboard and inboard boats, sailboats, marine engines, outboard motors, boat trailers, boating accessories and supplies.

B.I.A. certification means but one thing. When you, as a boat owner, have this certification, you can be assured that lighting, ventilation, steering, flotation, capacity, fuel system, horsepower rating and anything that will insure your safety are within the rigid U.S. Coast Guard requirements.

Your Cobalt is B.I.A. Certified and meets U.S. Coast Guard standards.

III. INTERIOR/EXTERIOR CARE

1. Vinyl Interior/Upholstery Care

The vinyl fabric in your Cobalt's interior was especially selected to take the tough punishment of the elements and hard usage of an active boater. One big, single caution, however, in the care of your interior is to avoid contact with sharp objects. With all its toughness and wear qualities it is no match for a screwdriver you forgot to take out of your back pocket before sitting down.

Keeping your Cobalt interior clean and beautiful is easy. Ordinary dirt can be removed by washing with warm water and a mild soap. Apply soapy water to a large area and allow to soak for a few minutes. Brisk rubbing with a cloth should then remove most dirt. This procedure may be repeated in case of stubborn or imbedded dirt. A soft bristle brush may be used after the soap has been applied. Other cleaning suggestions — Chewing gum may be removed by careful scraping and by the application of kerosene or naphtha. Tars, Asphalt, Creosote — each of these items will stain the vinyl if allowed to remain in contact. Wipe off as quickly as possible and clean the area using a cloth dampened with kerosene or naphtha. Paint should be removed immediately. Do not use paint remover or liquid type brush cleaner. Use a white cloth dampened with kerosene or naphtha. Nail polish and nail polish remover — these substances will cause permanent harm to the vinyl. Fast and careful wiping or immediate blotting after contact will minimize the staining. Spreading of liquid while removing should be avoided. Waxing and refinishing — waxing improves the wearability and cleanability of the vinyl. Use any hard wax.

CAUTION SHOULD BE EXERCISED IN USING FLAMMABLE SOLVENTS.

2. Vacuuming

A very effective and easy way to keep your interior ship shape is giving it a good vacuuming. You may use your own canister type or the ones available at a car wash. The vacuum cleaner allows you to pick up in tight areas such as under bow, jump and lounge seats. It's also a great way to clean up any debris in the bilge area. (If you're at a car wash, it's a good idea to use the pressure nozzle to wash the bilge area prior to vacuuming.)

3. Carpet Care

The carpet in your Cobalt is made of the finest materials available. It will not rot or mildew. Scrubbing with soapy water will handle most tough jobs. A simple hosing for mild cleanups will bring out that new look again. If your carpet accidentally gets stained with grease and normal soap and water won't clean it, you can use gasoline or acetone on a rag, provided it is used sparingly.

CAUTION: Use extreme caution while using any flammable liquids. Make sure you are in a well ventilated area.

4. Teakwood Care

While it is generally said that teakwood is maintenance free, it is better to consider teakwood as a material that requires a minimal amount of work to maintain.

If the care of teakwood is completely ignored, after a long period of time you can expect its color to turn gray. In addition to the fading of its color, the surface finish will tend to become rough. This roughing results and gradually becomes more apparent as the oil in the wood evaporates or dries out causing a shrinking and separation of the wood's grain.

For appearance sake and to avoid this "roughing" it is suggested that you use an application of the teak oil that was supplied with your Cobalt. Instructions for use are on the label.

5. Canvas/Top/Camper Care

Boat canvas is, in most cases, subjected to more severe punishment than practically any other type of canvas or fabric item.

Moisture, dirt, chemicals from industrial fallout, heat, ultraviolet rays and salt water (in some cases), are all factors anxious to destroy your boat top. These elements can do serious damage if left unchecked. Let's take these elements one at a time and see what we can do to slow their destructive process.

MOISTURE — Can cause shrinkage, mold, (and mildew if fabric is not properly treated). The best method of prevention is to allow all canvas items to dry thoroughly while installed on the boat. Shrinkage can occur anytime an article is allowed to dry while loose. Most shrinkage will occur the first few months after initial installation. When canvas items are erected on the boat and properly adjusted, shrinkage can only occur in areas of looseness. Mold and mildew can be avoided by keeping your unit clean and well ventilated.

DIRT — Can create a starting point for mold when moisture is present. Cleaning periodically with a mild detergent and water while unit is erected on the boat will extend the canvas life and provide a better appearance. Cleaning can be accomplished with a sponge, soft scrub brush or by using one of the serve-yourself car washes. Unit should always be erected fully and adjusted to a tight, smooth appearance before washing. Allow unit to air dry thoroughly before removing curtains.

CHEMICALS — From industrial fallout can cause decay of vinyls and fabrics if allowed to accumulate for long periods of time. There are so many different types of chemicals involved it would not be practical to try to describe them here. Keeping your unit clean is the best answer.

HEAT — Under certain conditions can cause plasticizer migration. Any vinyl coated fabric when enclosed in a polyethylene container and subjected to sunlight is subjected to potential migration of the vinyl plasticizers. This will result in cracks appearing in the vinyl component and a stiffening effect on the fabric. Polyethylene bags or tubes are meant only for protection during shipping and handling. DO NOT USE THEM FOR STOWAGE.

ULTRAVIOLET DEGRADATION — Most synthetic fabrics or nylon parts today are U.V.R. treated to resist ultraviolet effects. The best protection, however, is to avoid long periods of stowage in areas subjected to direct sunlight.

SALT WATER — Corrosive effects of salt water, as well as chemicals from industrial installation, can corrode brass or aluminum fittings of fasteners. Your canvas has snap fasteners made of stainless steel. These can be protected by keeping them clean and occasionally lubricating them with petroleum jelly.

In summary, the things you can do to protect your canvas items for extended years of enjoyment are:

1. Keep it clean. DO NOT use harsh cleaners.
2. Side curtains and rear window should demand extra care to prevent scratching. Ideally, they should be washed with clear water, preferably hosed off, wiping it with your hand at the same time. Do not attempt to use a cloth or chamois skin. Any dirt or grit in the cloth may result in scratches. Clear water and using your (clean) hand is the safest way.
3. Be sure that the top is completely dry before stowing.
4. Keep unit well ventilated when stowed. NO POLY BAGS.
5. Keep fasteners clean and lubricated.

The materials used to produce your boat top and curtains are the best obtainable. Reasonable care will assure you of a long life and many years of service.

WARNING: Do not use convertible tops, side curtains, aft curtain, etc., for storage. Adequate ventilation is not possible and mold/mildew will form. For storage, we recommend an optional travel/mooring cover made of duck canvas that does have the ability to breathe. For further information, see your Cobalt dealer.

IV. BOAT OPERATION

1. Erecting Canvas Top

- a. Convertible Top — standard
 1. Remove top and extension legs from “top storage area”.
 2. Attach extension legs to top mounts on each side of the boat. (Attaches with quick disconnect pins or with knurled knobs).
 3. Slide top bow onto extension legs with the short bow closest to the windshield.
 4. Remove storage boot and unroll canvas.
 5. Open frame and snap front of canvas to windshield.
 6. Snap the top tail panels to the sides of the boat.
- b. Side Curtains — optional
 1. Zip the side curtains to the top and then snap to the windshield and deck.
- c. Stern Curtain — optional
 1. Attach the stern curtain to the top with the zipper.
 2. Snap to the deck starting at the center rear and work forward evenly.
- d. Camper Top — optional
 1. The camper top erects in the same manner as the standard top with the exception of the forward edge which zips to the standard top. Please follow the same procedure outlined previously in “Standard Top”.
 2. Install camper top side/aft curtains by zipping to camper top, then to each other and then snapping to deck.
- e. Bimini Top — optional
 1. Remove top from top storage area.
 2. Attach to top mounts on each side of boat.
 3. Slide top bow onto extension legs with the short bows facing forward.
 4. Attach forward straps to eyelets on windshield.
 5. Attach aft straps to eyelets on the deck aft of the windshield.
 6. Adjust the straps as necessary for proper fit.

- f. Vista Cruiser Top — optional (21 Cuddy & 23's only)
 - 1. The Vista Cruiser Top erects in the same manner as the camper top. Please follow these instructions.
- g. Bowrider Tonneau Cover
 - 1. Open walk-thru doors.
 - 2. Snap cover to boat starting at bow and working aft.
 - 3. Close windshield center door and snap the canvas to the underside of the door.
 - 4. Walk-thru doors may be closed if desired.

NOTE: The standard canvas top and optional side and stern curtains must not be used for storage. The material does not allow for ventilation and mildew/mold may form on the interior of the boat. A duck canvas travel mooring cover is recommended for storage. Please consult your Cobalt dealer.

WARNING: Do not operate your Cobalt with the stern curtain or camper canvas completely closed. The cockpit must be open for fuel compartment ventilation.

2. Stowage of the Canvas Tops

The following is the recommended procedure for folding and storage of the top:

- a. Disconnect the tail panels from the side of the boat and allow them to hang free.
- b. Disconnect the top snaps from the windshield. (At this point, the two bows should still be separated.)
- c. Grasp the bows and fold them together. (Allow the canvas to gather between the bows.)
- d. Roll the canvas around the bows. (As you roll the canvas, insure its tightness and pull the side of the canvas to prevent wrinkling.)
- e. Slide the boot over the canvas and snap or zip.
- f. Remove the top from the “top bow extension legs” and stow the top in the “top storage compartment”.
- g. Remove the extension legs and stow them in the “top storage compartment”.

NOTE: Always make sure that all canvas is completely dry before storage or mildew may form.

3. Canvas Maintenance

The fabric is first soaked (with occasional agitation) in a solution with the following proportions of Clorox and Ivory Flakes.

1/2 cup (4 oz.) Clorox

1/2 cup (4 oz.) Ivory

1 gallon 'handwarm' water

The fabric remains in this solution until most of the stains disappear or for 20 minutes.

The fabric may be washed in an automatic washer on the COLD cycle using 2 cups (16 oz.) Clorox and one cup (8 oz.) Ivory Flakes. The fabric is then line dried.

UNDER NO CIRCUMSTANCES are these fabrics to be put in HOT WATER. UNDER NO CIRCUMSTANCES are these fabrics to be run through the HOT drying cycle of an automatic dryer. FABRIC SHOULD BE LINE DRIED. UNDER NO CIRCUMSTANCES ARE THESE FABRICS TO BE STEAM PRESSED AT A DRY CLEANERS.

If leaking occurs after washing this may be the result of insufficient rinsing. If the fabric continues to leak after a very thorough rinsing, it may be necessary to apply a coat of silicone air drying water repellent. This should be done on a warm sunny day, giving the application sufficient time to completely dry. Such silicone water repellents are available through Scotchgard or 3-M Company products.

4. Seat Adjustment and Operation 17BR, 18DV, 19BR, and 21BR

The driver's seat is adjustable fore and aft. To attain desired position, lift the release handle mounted under the forward lip of the driver's seat cushion, move seat, and release handle. Make sure handle retracts fully and seat is locked in place.

The passenger's seat is not adjustable.

To lay the sleeper seats down, simply grasp the forward edge of the seat cushion and lift until mechanism releases. Then extend into the sleeper position. On the driver's side, it will also be necessary to lift the release handle to slide the front of the mechanism to its most forward position. Reverse this procedure to replace in normal position.

While in the sleeper position, the after-most cushion can be raised and locked into a lounge position. To lock, press the support legs to an over center position. These are located under the cushion and are exposed when the cushion is raised.

223

Both captain's chairs are adjustable by turning the lock knob located under the seat on the outboard side counterclockwise, positioning the seat and tightening the lock knob.

CONDESA

Pilot's Seat

This seat is easily adjustable by loosening the knurled knob located outboard of the driver's seat. Move seat to the desired position and retighten the knob. The seat may be moved to its further most aft position for stand up driving. Passenger seat is not adjustable. Note: Stand up driving is not recommended.

Rear Bench Seat Assembly

The bench seat has two functions:

1. Engine Access

The seat slides forward to expose the engine(s). First release the locking slide bolts. Then, grasp the two handles in the front of the base and pull evenly. Reverse procedure to close this access.

2. Sleeper Position

First, slide the bench seat forward following the above procedure. Then, release the support straps (located on the back of the seat). Then, lower the back of the seat. The seat assembly may then be slid aft so that the back is resting on the support lip over the engine.

21CC, CS23

Pilot's Seat

Follow the same procedure as is used in the Condesa. The passenger's seat is not adjustable.

Rear Bench Seat Assembly

1. Engine Access

The entire bench seat assembly lifts for engine access.

2. Sleeper Position

Release the slide bolt on the front of the seat cushion. This will allow the cushion to slide forward forming a berthing area.

5. Cuddy Cabin Access Doors

a. CONDESA

Large bi-fold doors with companionway hatch.

To open, first unlock and raise the companionway hatch. Then, open doors and latch open with the hook under the inboard side of the dashboard. The rubber bumper on the side of the dashboard is adjustable to take up any slack between the door and the side of the dash. With the doors open, the companionway hatch can be lowered to obtain maximum visibility for the driver.

To lock from inside cabin, first slide the slide bolt located on the port side of hatch

opening to its most forward position. Then lock the key lock. From inside the cabin, with doors closed and hatch closed, slide the slide bolt aft over the key lock area. Small bi-fold access doors.

These are unlocked from inside the cabin. The slide lock assembly is controlled by the handle above the doors. They will remain in the open position by snapping them into the open position.

b. CS23

Large bi-fold doors.

To open, unlock key lock, and open main doors to starboard. Make sure they are secured in the open or closed position. Do not allow to swing free while underway. The port cabin door slides outboard for better cabin access.

c. 21CC, 223

Large bi-fold doors with companionway hatch.

To open, first unlock and raise the companionway hatch. Then, open doors and use the strap to secure in the open position.

6. Instrument Panel

1. Clock — Electric
2. Fuel Gauge — shows approximate amount of fuel remaining in tank.
3. Voltmeter — shows the condition of charge in the battery. Only indicates while the ignition is in the “on” position. With the engine at idle or not running, it may show as low as 10 to 12 volts. With the engine running at cruising speeds and above, it should show 12 to 14 volts.
4. Speedometer (Miles Per Hour)
5. Rudder Indicator — Shows position of drive unit in reference to the center line of the boat.
6. Tachometer(s) — (Revolutions Per Minute)

In twin engine installation, it would be very unusual for both engines to indicate exactly the same. The reasons for this are:

 - a. The power steering pump is on one engine only. This pump will normally slow this engine down approximately 150 RPM at maximum throttle setting.
 - b. Engine tune. It is almost impossible to tune two engines identically the same and therefore the top RPM's may vary.
 - c. Propellers. If either propeller is dented or the blades are slightly damaged, this may cause a difference in readings.
 - d. The tachometers, themselves, may indicate slightly differently.

Summary — A slight difference of 50-200 RPM is normal at top RPM. If more difference is noted, check with your Cobalt dealer.

7. Oil Pressure Gauge(s)

Pressure can vary according to type of engine. It is normal for a hot engine to have low pressure at idle, (depending on type of oil, pressure may drop as low as 10 PSI at idle). Oil pressure should be maintained as follows:

MerCruiser

In Line Engines 30-60 PSI @ 2000 RPM

V-8 Engines 30-55 PSI @ 2000 RPM

OMC

V-6 Engines 30-50 PSI @ 2000 RPM

V-8 Engines 30-50 PSI @ 2000 RPM

Volvo

V-8 Engines 30-50 PSI @ 3000 RPM

DANGER: Should oil pressure drop below 30 PSI at the indicated RPM, there is a malfunction in the engine or gauge or a low level of oil. Check immediately before further operation.

8. Temperature Gauge(s)

Temperature may fluctuate slightly while running. Maximum temperature may vary depending on type of engine.

DANGER: Should water temperature reach 180 degrees Fahrenheit, your engine is overheating and should be checked immediately for probable cause.

9. Trim Gauge(s) — Shows the position of the drive unit(s) in reference to the bottom (keel) of the boat.
10. Horn Button — Horn is mounted under deck on starboard side.
11. Lighter.
12. Bilge Blower Indicator — Indicates when bilge blower is operating.
13. Bilge Pump Indicator — Indicates when bilge pump is operating in manual or automatic mode.
14. Interior Light Indicator — Indicates when interior lights are on.
15. Dash Light Indicator — Indicates with dash instrument lights.
16. Exterior Light Indicator — Indicates with navigation or anchor lights.
17. Two Position Switches — Controls equipment as labeled.

18. Three Position Exterior Light Switch
Up position — navigation (running) lights, bow light and stern light. Center position — off. Down position — stern light only.
19. Circuit Breakers
Push to reset if necessary. If the button continues to pop out, consult your Authorized Cobalt Dealer.
20. Ignition Key Switch
21. Indicator Light — For auxiliary equipment.
22. Low Fuel Indicator — Will momentarily light when ignition is first turned on. It will indicate with approximately $\frac{1}{8}$ tank or less.
23. High Temperature Indicator — Will momentarily light when ignition is first turned on. It will indicate when engine temperature exceeds approximately 170 degrees.
24. Low Oil Pressure Indicator — Will momentarily light when ignition is first turned on, then go off. If the engine is not started, and the ignition key is left on, it will indicate after approximately 30 to 60 seconds (warm up). It will immediately indicate when oil pressure drops below 5 - 7 lbs.

NOTE: Many Chevrolet V-8 engines will idle when hot with pressure in this range which will make the indicator light flicker slightly. This is normal. If the light indicates steadily, have your dealer check the system before further use.

NOTE: Items 23 - 25 are dealer adjustable to suit your individual needs.
25. Low Voltage — Will momentarily light when ignition is first turned on. It will indicate if the electrical system drops below 10.8 volts. If the engine is not running with the ignition on, or at a dead idle, and you have many electrical items turned on such as lights, blower, pump, etc., the light may indicate. If the engine is accelerated above approximately 1500 RPM, the light should go off after a few seconds.

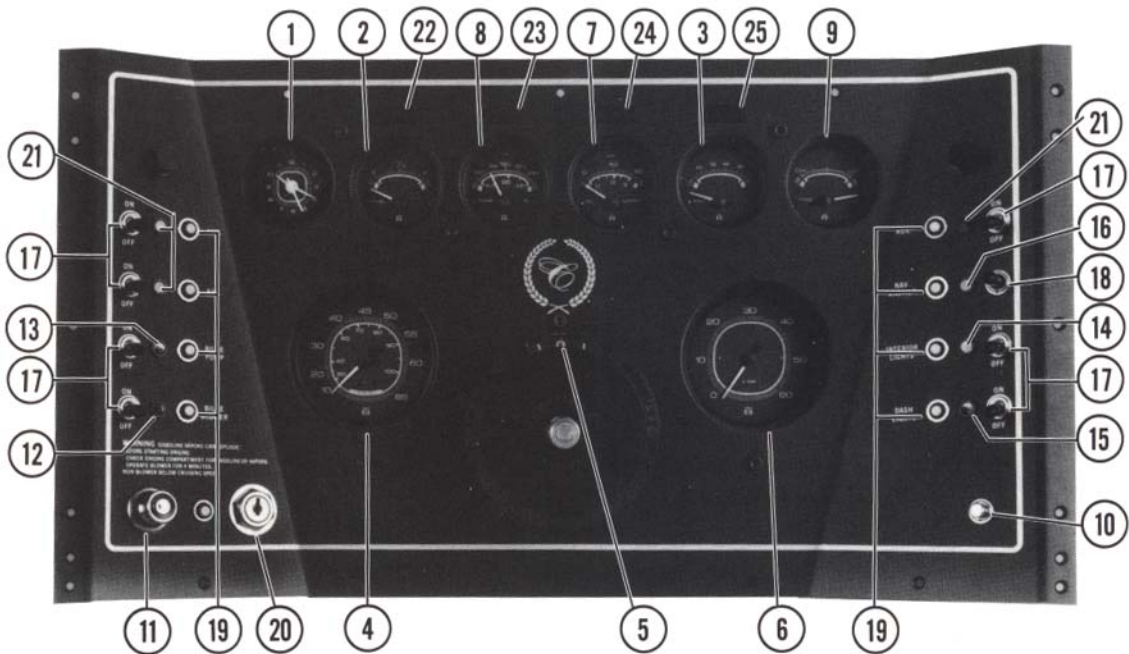

18DV-19BR INSTRUMENT PANEL

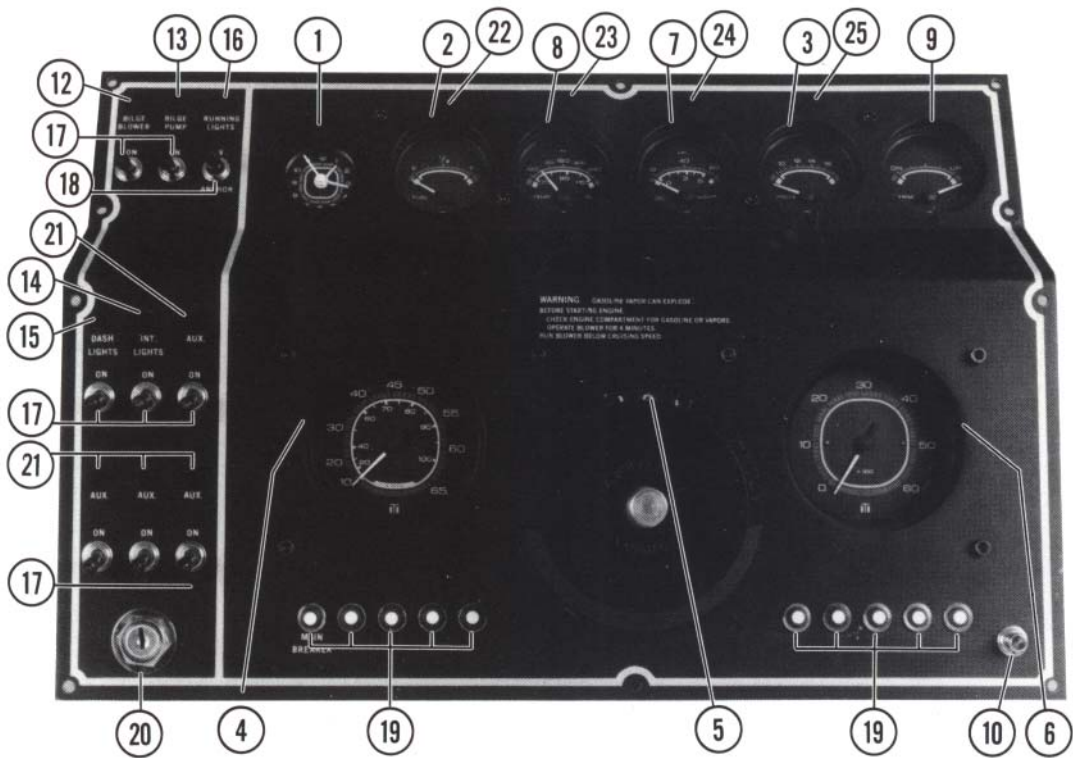

21BR, 21CC, 223 CONDURRE INSTRUMENT PANEL

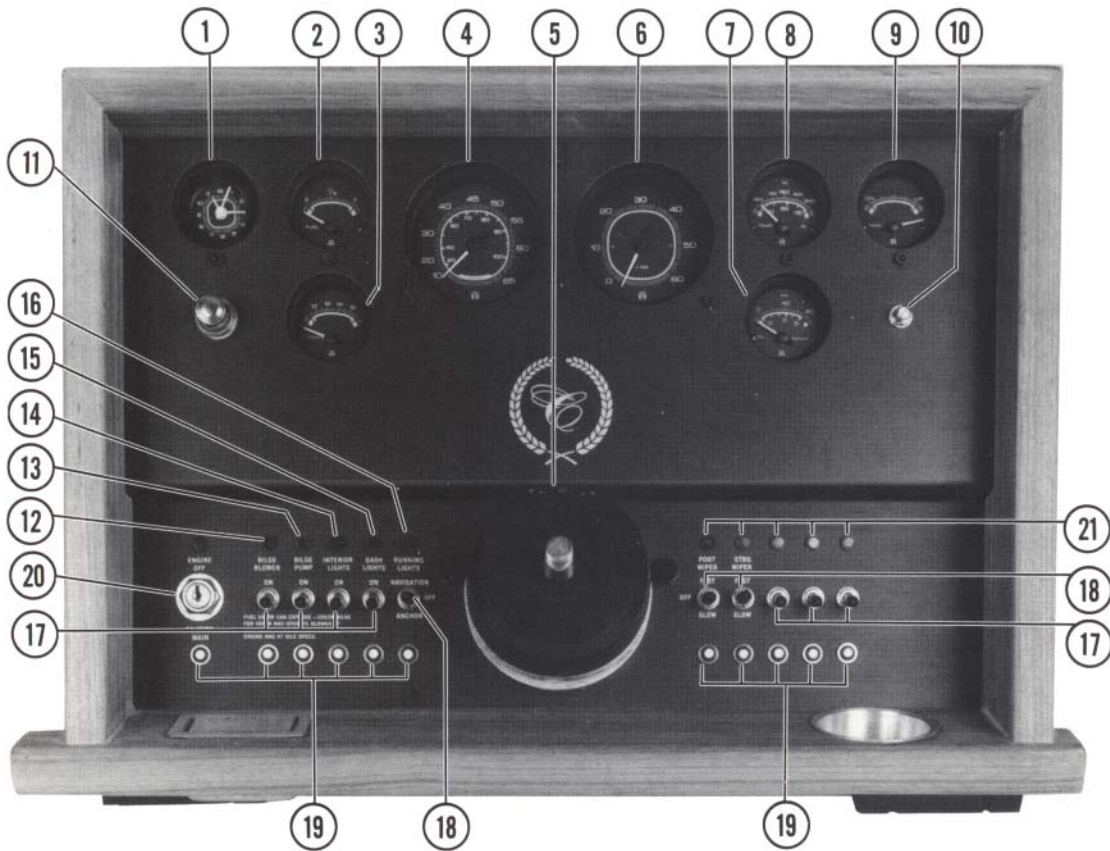
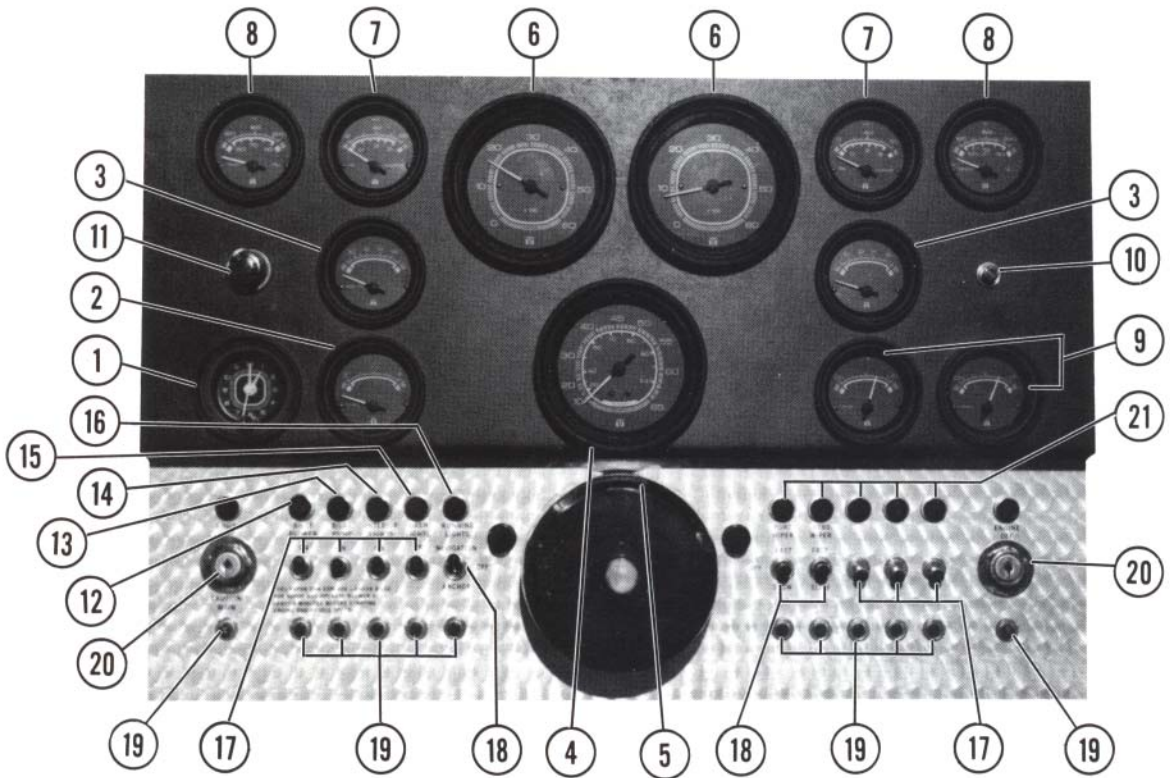

Figure 2
CONDESA SINGLE ENGINE
INSTRUMENT PANEL



**CONDESA TWIN ENGINE
INSTRUMENT PANEL**

7. Engine Control

Single Engine Models

The engine control controls shifting, throttle and incorporates the power trim control which is covered in another section entitled “Power Trim”.

OMC and Volvo

Engine will start only in neutral. To move handle from neutral position (vertical), lift the button under handle, then move handle. Moving handle forward will engage forward gear initially. Continuing forward movement will advance throttle. Moving handle aft will engage reverse gear initially. Continued aft movement will advance throttle.

Cold Starting — While handle is in neutral position, pull entire handle away from side of boat and move handle forward. This will allow you to advance the throttle while leaving the shift mechanism in neutral.

MERCUISER

The same procedure is used for MerCruiser as for the OMC. For cold starting, while handle is in the neutral position, depress button in the center of the bottom of the handle and move forward. Please consult the engine owners manual.

Twin Engine Models

The engine control in your twin engine Cobalt controls shifting and throttle.

The engines will only start in neutral. Moving handles forward will engage forward gear. Moving handles aft will engage engines into reverse gear. Continuing movement in either direction past gear engagement will advance the throttles. The handles may be used as one to control both engines at the same time or independently to advance the throttle of one engine more than the other. It is also possible to shift one engine in forward and the other in reverse for maneuvering at dead slow speeds.

Cold Starting — While the handles are in the neutral position, pull the handles away from the control assembly and move handles forward. This will allow you to advance the throttles while leaving the shift mechanisms in neutral.

8. Steering System

The steering system in your Cobalt is the finest available in the boating industry today. It is a mechanical system, with power assist in all installations.

Steering/Propeller Torque

Steering or propeller torque is always present in any drive system. In some systems, it is more noticeable than in others. Your boat has power steering and you should not encounter this torque to any significant degree. If you encounter movement in the steering wheel when released, please check with your dealer. It may be necessary to adjust the power steering assembly.

Wandering/Fishtailing

Wandering is a characteristic of all deep vee bottom boats at slow speed. There is no cure for wandering, however, a very basic operational technique can be applied which will minimize this characteristic. If the steering wheel is moved back and forth to compensate for wandering, invariably, the situation will be accentuated. If the steering wheel is left in a centered position, the boat will wander back and forth slightly, however, the overall course of the boat will be a straight one.

The steering is the most important system in the entire boat from a safety standpoint. It should be inspected by a qualified mechanic at regular service intervals.

9. Power Trim

General

Single Engine

The power trim changes the drive unit angle in reference to the transom of the boat. Regardless of engine type, a few basic operating techniques should be applied.

1. The drive unit should be lowered fully prior to initial acceleration.
2. After the boat has attained planing speed (18-24 MPH), the trim should be raised for maximum speed and handling characteristics.
3. If the trim is raised too high, porpoising (bouncing) and cavitation (propeller slippage) can occur.
4. It will be necessary to readjust the trim angle as boat speed changes.

Twin Engine

Your power trim is controlled by two (2) switches mounted on the engine control console. For general operating characteristics, please refer to the power trim, "Single Engine" section. The basic operating techniques remain the same for twin engine as for single.

The power trims may be operated simultaneously as one unit and will have the same effect as a single engine power trim system. In addition to this, the power trims, like the throttle controls, may be operated independently of each other. This will enable you to correct for side to side trim by raising or lowering one of the drive units independently of the other. For example, if the boat were leaning to the starboard side, it would be possible to compensate by raising the port drive unit slightly higher than the starboard unit. Conversely, if the port side of the boat was down, it would be possible to compensate for this by raising the starboard drive higher than the port drive. It is important to remember that correcting for side to side listing or lean can be compensated for only when the boat is on plane, above 18 to 24 MPH. Once the list or lean has

been eliminated, the drive units can be raised or lowered together as one without a significant change in the side to side position of the boat.

Single Engine Models

Your power trim is controlled from the engine control handle.

MerCruiser — Please consult your engine owners manual.

OMC — Your engine control is made by Morse Control and incorporates trim/tilt buttons in the side and bottom of the hand grip. The switch on the bottom of the hand grip will raise and lower the drive for trimming. The buttons on the side of the hand grip control the tilting. The ignition must be turned on to operate these controls. NOTE: Do not run engine with the drive tilted. See your engine owner manual.

Volvo — Your engine control is made by Morse Control and incorporates trim/tilt buttons in the side and bottom of the hand grip. the switch on the bottom of the hand grip will lower the drive from any position and raise the drive for trimming. The buttons on the side of the hand grip will raise the drive for trailering. They will also lower the drive from any position.

Twin Engines Models

The power trim/tilt is controlled by toggle switches. The switches without the protectors are the trims.

MerCruiser & Volvo — The trim toggle switches will lower the drives from any position. They will also partially raise the drives. To fully raise the drives, it is necessary to operate the trim switches and the tilt switches (protected) simultaneously.

OMC — The trim toggle switches will operate the trim motors only. The tilt switches (protected) will operate the tilt motors only. NOTE: Do not operate engine(s) with the drive(s) tilted. See your engine owners manual.

10. Warning Labels

Your Cobalt has several warning labels displayed to point out safety hazards. The areas are as follows:

a. Boarding Ladder/Swim Platform

“WARNING: Under no circumstances should anyone be allowed to enter or exit your Cobalt from the boarding ladder or swim platform while engine is running.”

b. Engine Flame Arrestor

“Leaking fuel is a fire and explosion hazard. Inspect fuel system regularly. Examine fuel tank for leaks or corrosion at least annually.”

c. Dashboard

“Operate Bilge Blower at least two minutes before starting engine. Run continuously during starting and below cruising speeds.”

d. Windshield Wing, Driver’s Side Cobalt Check List

For maximum enjoyment and safety, check each of these items BEFORE you start your engine:

- DRAIN PLUG (Securely in place?)
- LIFE-SAVING DEVICES (One for every person on board?)
- STEERING SYSTEM (Working smoothly and properly?)
- FUEL SYSTEM (Adequate fuel? Leaks? Fumes?)
- BATTERY (Fully charged? Proper water level?)
- ENGINE (In neutral?)
- CAPACITY PLATE (Are you overloaded?)
- WEATHER CONDITIONS (Safe to go out?)
- ELECTRICAL EQUIPMENT (Lights, horn, pump, etc.?)
- EMERGENCY GEAR (Fire Extinguisher? Bailer? Paddle? Anchor and Line? Signalling Device? Tool Kit? Etc.?)

e. RECOMMENDED SAFETY RULES

- REMAIN SEATED WHILE UNDERWAY
- AVOID USING REAR PAD OR SUNDECK WHILE ENGINE IS RUNNING
- DO NOT USE BOARDING LADDER WHILE ENGINE IS RUNNING
- TURN OFF ENGINE AND ALL ELECTRICAL SYSTEMS WHILE RE-FUELLING
- TURN OFF ENGINE(S) WHEN SWIMMERS ARE NEAR BOAT

f. WARNING: Maneuverability above 50 MPH is limited. Sudden turns may cause loss of control.

11. High Speed Operation

a. Maneuverability

When operating any boat at high speed, a great deal of caution must be exercised. This is particularly true during turns. Gradual turns can be completed at high speed by a competent driver but it must be emphasized that sudden turns at any speed and particularly at high speed can be especially dangerous. It is possible to throw passengers from their seats and even from the boat if caution is not exercised. Remember, common sense is the rule for safe boating.

b. Wake Jumping

Your Cobalt is not designed for wake jumping. When crossing another boat’s wake, it is recommended that you throttle back so as to prevent your boat from

leaving the water. Wake jumping can be very dangerous. It is possible for the boat to re-enter the water on its side, transom, or bow. In any of these instances, you and your passengers could suffer serious injury. Also, damage to the boat could take place causing a hazardous condition.

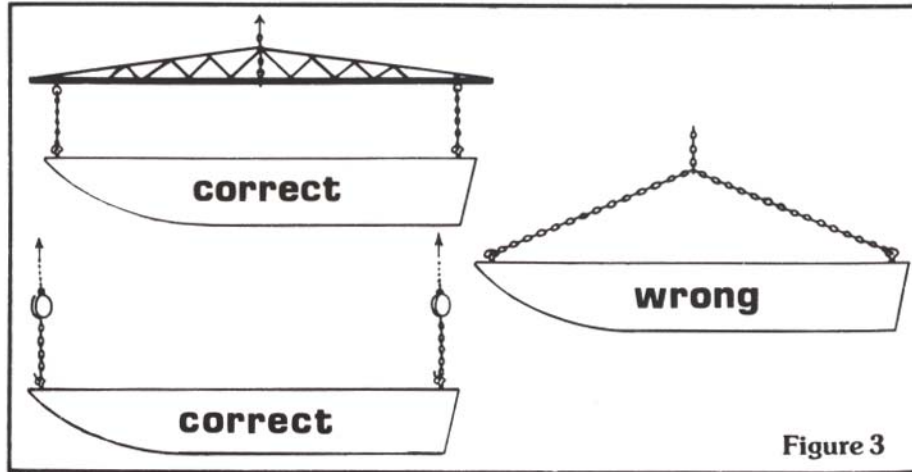

Fig. #3 illustrates the correct and incorrect hook-up for lifting.

**12. Lifting Rings On Your Cobalt (See Fig. #3)
(18DV, 19BR, 21'S, CONDESA Only)**

The lifting rings on your Cobalt have been strength tested by an independent testing laboratory and are found to be capable of withstanding almost 2½ times the weight of the boat.

Keep in mind however, that there is a proper way to lift your Cobalt. Lifting pressure should always be vertical from the rings. Improper lifting could cause damage. If only one hoist is used, a spreader bar must be employed to avoid side strain on the rings.

NOTE: Lift rings must not be used for storage. After your Cobalt is lifted into position, support must be placed under the hull and all of the weight removed from the lifting rings. For further information, please consult your Cobalt Dealer. Fig. #3 illustrates the correct and incorrect hook-up for lifting.

**13. Trash Receptacle
18DV, 19BR**

To remove this compartment, first open fully. Then lift up and pull out from the bottom. After it clears the lower lip, lower and remove. To reinstall, reverse the procedure.

21BR

To remove, open hanging locker door and release the expansion cord from the back of the trash receptacle. The receptacle can then be removed.

21CC, CS23, CONDESA

Your Cobalt is equipped with a trash receptacle. It is located under the driver's captain's chair. To release, pull receptacle open.

14. Fold Down Boarding Ladder

THIS LADDER MUST ONLY BE USED WHILE ENGINE IS OFF. (See warning label section). To lower, unsnap securing strap, and lower. Be sure ladder is raised and secured prior to starting engine. Caution should be used while using this ladder, in that any substance can be slippery when wet.

15. Water Ski Towing

If your Cobalt has lifting rings, the ring may be used for water skiing lines. In other models, the ski tow hook may be used for one or more lines. In all models, the transom eyes or stern cleats may be used.

16. Deck Hatch

21CC, CS23, 223, and Condesa

The deck hatch is manually operable. To open, simply release the one or two hasps on the forward edge of the hatch, make sure the support bracket adjusters are loose, and raise the hatch to the desired position and secure the adjusters.

WARNING: Do not use a raised hatch for support while on the deck.

17. Engine Accessibility

Standard Interior

17BR, 18DV, 19BR

1. Open engine box by using teak handle. Do not lift on the underside of the jump seat cushion. When closing the motor box, do not allow the box to "slam shut".

CONDESA

The engine(s) in your Cobalt is accessible by sliding the bench seat assembly forward and opening the engine cover behind the seat.

First, open slide bolts on the forward end of the bench seat base. Then, using the handles on the front of the base, pull seat assembly forward to the stops. It is important to pull evenly on these handles or the seat may bind. If it does, push seat closed and repeat operation.

When the seat is forward, it is then possible to release the two slide bolts on the engine hatch (located under rear deck lid) and raise the hatch to fully expose the engine(s).

For major service, it is possible to remove the engine box by releasing the spring loaded disconnects on the sides of the motor box (two per side) and remove the entire box from the boat.

21BR, 21CC, CS23

Open the engine box by lifting the teak handle. When closing, do not allow the box to “slam shut”. The position of the bench seat has no effect on the operation of the motor box itself.

Condurre 223

Motor box lid is electrically controlled. Make sure battery switches are turned on and operates the appropriate switch on the dash. If the battery is dead, simply lift the hatch by hand (quite heavy). The electric mechanism automatically disconnects.

Optional Interiors

Sundeck — 18DV, 19BR

Open engine box by using teak handle. Do not lift on the underside of the seat cushion. When closing the motor box, do not allow the box to “slam shut”.

Sundeck — 21BR

Open sundeck lid. For further access, open the slide bolt on each side panel and open bi-fold door for access to the sides of the engine.

18. Dual Batteries and Dual Battery Switches (Twin Engines)

Your twin engine Cobalt is equipped with two batteries and two battery switches. The basic purpose of this system is to enable you to allow either engine to charge either/or both batteries. It also enables you to isolate one battery from the entire electrical system while using the other. From a safety standpoint, this will prevent you from accidentally running both batteries down when using electrical equipment without operating the engines.

- a. Line up the starboard engine battery switch to “position 1” and the port engine battery switch to “position 2”. (Normal Operation)
- b. Starboard engine battery switch to “position 2” and the port engine battery switch to “position 1”. (Normal Operation)
- c. If you want one engine to charge both batteries, place that engine’s battery selector switch to the “all” position and the other engine’s selector to “off”. (Emergency Only)
- d. If you want both engines to charge one battery, place both battery switches on either “position 1” or “position 2”, depending on which battery you want charged. (Emergency Only)

- e. If you want both engines to charge both batteries, put both battery switches in the “all” position. (Emergency Only)

To isolate the batteries from the electrical system for storage purposes or for charging from an external battery charger, place both switches in the “off” position.

CAUTION: If both engines are allowed to charge both batteries at all times, an overcharged condition of one of the batteries or both can exist. Under normal operating circumstances, it is important that each engine be selected to its own battery only.

19. Optional Equipment

a. Swim Platform

To avoid damage to the optional swim platform, always be sure the outdrive unit is in the straight ahead position before tilting the outdrive all the way up. (Single Engine Only)

NOTE: Make sure the engine is shut off before using swim platform.

b. Camper Top

See Section IV Boat Operation 1. Canvas.

c. AM/FM Stereo Cassette

There are separate instructions in the owner’s packet that give specific instructions for operation.

d. Remote Control Spotlight

1. Has both flood and spot beams controlled by a three position switch on the spotlight control panel.

NOTE: The spotlight control panel has two (2) fuses behind it accessible by removal of the panel itself. The fuses are for the bulb and the spotlight motor.

2. Rotates more than 360 degrees and will travel up and down by using “joy stick” control.
3. Speed at which spotlight moves is controlled by the black knurled knob.

e. Docking Lights

Controlled by “aux” switch on dash.

f. Trim Tabs

The trim tabs are a separate system in themselves and are not to be used in lieu of the engine power trim system.

1. Before accelerating, make sure the tabs are both fully raised.

2. Do not use the tabs until the boat has reached the desired speed and the power trim has been adjusted to the proper setting.
3. Operate only one tab at a time and in small increments. As the tab takes effect, you will notice it causes the boat to veer off course slightly. Correct for this as it happens. In other words, it will be necessary to use the trim tab and correct the steering simultaneously.

Basic operating techniques — Bow high attitude

1. Make sure both tabs are fully raised.
2. Lower both tabs simultaneously for approximately five seconds.
3. Accelerate the boat to planing speed and see if the desired effect is attained.
4. If not, raise or lower both tabs until desired attitude is obtained.
5. After desired attitude is obtained, one trim tab may be adjusted independently of the other to compensate for listing.
6. Make it a habit to raise both tabs each time the boat is slowed to less than planing speed.

NOTE: If in doubt, raise the tabs completely and start over again.

g. Extra Battery and Switch (Single Engine)

This option gives you the ability to isolate the entire boat from the batteries, and switch to either or both batteries. Under normal situations, the switch should be in “position 1” or “position 2” rather than the “all” position. This will keep one battery in reserve should the other fail. Battery selection should be made with engine off only. We recommend alternating batteries on a daily basis.

h. Portable Head

Please consult the owner’s manual supplied with the head for proper operation.

V. PROPELLERS AND PROPELLER CHART

Propellers — General

Nothing is more important to the proper performance of your boat than the condition of the propeller(s). Even minor damage (often invisible to the naked eye) can adversely affect the boat's performance. Common symptoms of damage to propellers are a sudden drop in RPM, vibration or sudden loss of speed.

A propeller is measured by two dimensions: 1) the diameter; and, 2) the pitch. The diameter is determined by measuring the distance from the center of the propeller to the tip of one blade and multiplying that figure by two. Pitch is expressed in the number of inches a prop will advance in a solid medium in one revolution.

Operational characteristics of your boat, including its speed, may change due to several factors: atmospheric conditions; additions of extra equipment and accessories or passengers; marine growth on the bottom; and, engine condition. Other factors include damage to the prop(s), tides, water temperature and direction of wind. Some of these factors are directly correctable by repair or maintenance. Others are beyond human control. A few which may be considered permanent operating conditions may be compensated for by a change in prop(s). Such a change should not usually be undertaken without the advice of a knowledgeable and experienced boatman or your dealer unless you are prepared to spend much time and money on hit and miss methods that may or may not result in improved performance.

Stainless Steel

For the ultimate in top speed, stainless steel propellers will increase top speed by two to four MPH. However, they will do so at the sacrifice of some of the pulling power for water skiing and heavy loads. Stainless steel propellers should only be used when additional speed is desired. Under normal usage, aluminum propellers will give you the best overall performance. Keep in mind that if hitting a submerged object, aluminum will bend easier than stainless, absorbing most of the shock and help protect the stern drive. On the other hand, stainless may not bend and transmit the shock into the drive which could cause internal damage. For further information, please consult your Cobalt dealer.

Pulling Power

If you need extra pulling power, you can obtain this by decreasing the pitch of your propeller(s) by two degrees. This will not endanger the engine or drive unit as long as the manufacturer's recommended top RPM is not exceeded and should only be done with an experienced driver at the helm. Generally, an aluminum propeller will out-pull a stainless steel propeller of the same pitch size.

STANDARD PROP CHART

	<u>17BR</u>	<u>18DV</u>	<u>19BR</u>	<u>21CC, 21BR</u>	<u>Condurre 223</u>
185 MER V-6	13 ³ / ₄ x 21C 48-78122A4	13 ³ / ₄ x 21C 48-78122A4	N/A	N/A	N/A
190 MER 4	N/A	13 ³ / ₄ x 21C 48-78122A4	N/A	N/A	N/A
200 MER (1.65) V-8	N/A	14 x 19C 48-78120A4	N/A	N/A	N/A
230 MER V-8	N/A	14 x 19C 48-78120A4	14 ¹ / ₂ x 17C 48-78118A4	14 ¹ / ₂ x 17C 48-78118A4	14 x 19C 48-78120A4
260 MER V-8	N/A	13 ³ / ₄ x 21C 48-78122A4	13 ³ / ₄ x 21C 48-78122A4	14 x 19C 48-78120A4	13 ³ / ₄ x 21C 48-78122A4
185 OMC V-6	N/A	14 ¹ / ₂ x 19C 391201	N/A	N/A	N/A
205 OMC V-6	N/A	14 ¹ / ₂ x 19C 391201	N/A	N/A	N/A
230 OMC V-8	N/A	14 ¹ / ₂ x 19C 391201	15 x 17C 391200	15 ¹ / ₂ x 15C 391535	N/A
260 OMC V-8	N/A	14 ¹ / ₄ x 21C 391202	14 ¹ / ₂ x 19C 391201	15 x 17C 391200	N/A

STAINLESS PROP CHART

	<u>17BR</u>	<u>18DV</u>	<u>19BR</u>	<u>21CC, 21BR</u>	<u>Condurre 223</u>
185 MER V-6	13 ³ / ₄ x 21C 48-73982A4	13 ³ / ₄ x 21C 48-73982A4	N/A	N/A	N/A
190 MER 4	N/A	13 ³ / ₄ x 21C 48-73982A4	N/A	N/A	N/A
200 MER (1.65) V-8	N/A	14 x 19C 48-73980A4	N/A	N/A	N/A
230 MER V-8	N/A	14 x 19C 48-73980A4	14 ¹ / ₂ x 17C 48-79794A4	14 ¹ / ₂ x 17C 48-79794A4	14 x 19C 48-73980A4
260 MER V-8	N/A	13 ³ / ₄ x 21C 48-73982A4	13 ³ / ₄ x 21C 48-73982A4	14 x 19C 48-73980A4	13 ³ / ₄ x 21C 48-73982A4
185 OMC V-6	N/A	14 ¹ / ₄ x 21C 389923	N/A	N/A	N/A
205 OMC V-6	N/A	14 ¹ / ₂ x 19C 389924	N/A	N/A	N/A
230 OMC V-8	N/A	14 ¹ / ₂ x 19C 389924	15 x 17C 391290	15 x 16C 389925	N/A
260 OMC V-8	N/A	14 ¹ / ₄ x 21C 389923	14 ¹ / ₂ x 19C 389924	15 x 17C 391290	N/A

Turbo™ Propellers are available for most installations. They will normally increase top end speed by 1-3 MPH with no detrimental effect on low end acceleration or pulling power.

CONDESA, CS23

STANDARD PROP CHART

<u>SINGLE</u>	<u>CONDESA, CS23</u>
260 MER	14 x 19C 48-78120A4
260 OMC	15 x 17C 391200
<u>TWIN</u>	
185 MER	NOT TESTED
190 MER	13 ¹ / ₂ x 23C 48-78124A4
200 MER (1.65)	14 x 19C 48-78120A4
230 MER	13 ³ / ₄ x 21C 48-78122A4
260 MER	13 ¹ / ₂ x 23C 48-78124A4
185 OMC	NOT TESTED
205 OMC	NOT TESTED
230 OMC	14 ¹ / ₂ x 19C 391201
260 OMC	14 ¹ / ₂ x 21C 391202
330 MER	N/A
370 MER	N/A
400 MER	N/A
440 MER	N/A

STAINLESS PROP CHART

<u>SINGLE</u>	<u>CONDESA, CS23</u>
260 MER	14 x 19C 48-73980A4
260 OMC	15 x 17C 391290
<u>TWIN</u>	
185 MER	NOT TESTED
190 MER	13 ¹ / ₂ x 23C 48-75724A4
200 MER	14 x 19C 48-73980A4
230 MER	13 ³ / ₄ x 21C 48-73982A4
260 MER	13 ¹ / ₂ x 23C 48-75724A4
185 OMC	NOT TESTED
205 OMC	NOT TESTED
230 OMC	14 ¹ / ₂ x 19C 389924
260 OMC	14 ¹ / ₄ x 21C 389923
330 MER	N/A
370 MER	N/A
400 MER	N/A
440 MER	N/A

VI. TECHNICAL INFORMATION

1. Engine Operation/Maintenance/Serviceing

Included with your owner's packet is your engine manual(s). This manual was prepared by the engine manufacturer and contains virtually everything you'll need to know concerning operation and care of your engine. It is a good idea to read this manual thoroughly and become acquainted with this information.

It is advisable to maintain a service log to record service checks, such as oil changes, so you can determine when it's time for servicing.

2. The Break-In Period

We cannot stress enough, the importance of reading your engine manual(s) and following the manufacturer's instructions for breaking-in your engine(s).

The comments here on this subject are of a general nature. Your engine manual(s) will give you the engine manufacturer's specific recommendations.

The engine is the very heart of your boat. Proper maintenance is essential. In general, it consists of: proper lubrication; clean fuel lines and carburetor; periodic cleaning and adjustment of spark plugs; and, distributor point and spark timing.

For detailed engine work, we recommend that you obtain the services of an authorized OMC, MerCruiser or Volvo dealer.

Keep a close check on oil pressure and temperature gauges at all times. Use only the correct octane fuel recommended by the engine manufacturer.

Preventive maintenance will prevent many heartbreaking and sometimes costly repairs.

3. Winterizing and Off-Season Storage

- a. Preparing for winter lay up is vital for the preservation of your Cobalt. In frigid zones, you must be particularly attentive to items that can be damaged by freezing.
- b. Step by step instructions on what must be done to your engine(s) for winter storage is outlined in your engine manual(s). Follow these essential instructions carefully. This manual also details procedures for returning your engine(s) to service for in-season usage.
- c. Good storage is very important, be it wet or dry. Proper storing or blocking is necessary to properly support the hull when stored dry.
- d. Provide adequate ventilation if canvas covered. Be sure there are openings at both ends so that a thru draft is created.
- e. Remove battery. Store on wooden shelf or wood base. Store in dry covered place,

charged to capacity and check it periodically during the off-season. Recharge monthly.

- f. If you are able to obtain regular leaded fuel without alcohol, store your Cobalt with the fuel tank full. It is also advisable to add fuel preservative to your tank during winter months or any long periods of storage.

If you are using alcohol blended regular fuel, and most of us are, it is desirable to have the fuel system drained completely. Alcohol attracts water which can corrode aluminum parts such as fuel tanks, fuel pumps, carburetors, etc., during storage periods. It also can deteriorate flexible fuel lines between the fuel tank and fuel inlet of the engine.

- g. It is vital that your Cobalt be stored with the bow slightly elevated; i.e., the same attitude as if the boat were floating at rest. If the boat is stored with the bow down, any moisture will not be able to get out and mold/mildew may form.

4. Fuel Requirements

Marine engines are designed to be operated with regular leaded fuel. As you know, the lead is being removed and alcohol is being substituted as an octane booster. Alcohol can have a detrimental effect on fuel lines, fuel tanks, fuel pumps and carburetors.

At Cobalt, we are most concerned with the safety aspect of the life of the fuel line between the fuel tank and the fuel inlet of the engine. This line is made of a synthetic, flexible material and although it is the best material available, alcohol can deteriorate it especially during periods of storage. For this reason, it is suggested that you have your Cobalt dealer inspect this fuel line at least annually and replace, if necessary.

The situation with fuels and the composition of fuel lines is changing very rapidly, therefore please keep in touch with your Cobalt dealer.

The performance of the engine may also be affected with the changing fuels. Please read your engine owners manual for recommended fuel usage.

5. Trouble Check Chart

Trouble	Possible Cause	Action
Engine won't start	1. Lack of Fuel	Check fuel.
	2. Clogged anti-syphon valve	See authorized Cobalt Dealer.
	3. Clogged fuel tank pick-up	See authorized Cobalt Dealer.
	4. Clogged fuel filter	Replace fuel filter.
	5. Plugged fuel line or defective pump.	Fuel pump may be defective. Inspect pumpsight glass for fuel leakage from fuel pump. See authorized service dealer.

	6. Carburetor float valve stuck	Tap float chamber with a screwdriver handle to free needle valve.
	7. Damp spark plugs	Dry ceramic with clean dry cloth.
	8. High tension leads wet and/or loose	Dry and tighten connections at spark plugs, distributor and coil.
	9. No spark	Check high tension lead on coil.
	10. No spark	Check for loose connections on coil.
	11. Water in fuel supply or old gasoline	Check fuel supply for water contamination. If gasoline is old or if water is present, drain fuel tank and flush with fresh gasoline
Starter won't crank engine	1. Ignition Switch	If inoperative, see Dealer.
	2. Throttle Position	Check to see that remote control is in start position. Change position of throttle ever slightly.
	3. Dead battery	Check level of electrolyte, disconnect battery. Charge battery.
	4. Battery connections loose or corroded	Check for loose connections and corrosion. Clean connections and tighten.
	5. Starter connections loose	Check connections and tighten. If solenoid clicks when attempting to start engine, check battery connections. If condition persists, see your Authorized Service Dealer.
Engine runs erratically	1. Automatic choke out of adjustment	See your Authorized Service Dealer
	2. Water and/or dirt in fuel filter	Clean and inspect filter.
	3. Fuel pump malfunction	Check operation of pump. Replace fuel pump. See your Authorized Service Dealer.

Engine vibrates	4. Fuel tank vent and line plugged	Check for restrictions in line and vent. Blow out line and vent.
	1. Propeller condition	Check for bent, broken or damaged propeller. Check for weeds on propeller or gearcase.
	2. Carburetor out of adjustment.	Adjust carburetor.
	3. Spark plug condition	Check spark plug electrodes and ceramic. Clean and regap. Replace plugs, if necessary.
	4. High tension leads loose or deteriorated	Insure all connections are clean and tight.
	5. Incorrect firing order	Correct firing order, see engine manufacturer's owner's manual for specifications.
Engine runs but boat makes little or no progress	6. Engine out of time	Check timing and dwell specifications of engine. See your engine manufacturer's owner's manual.
	1. Fouled or damaged propeller	Check for weeds on propeller, bent or broken propeller. Remove weeds or replace a damaged propeller. Check outdrive and hull for excessive marine growth.
Performance loss	1. Throttle not fully open	Check to see that throttle opens fully at carburetor.
	2. Improper fuel	Fill tank with correct fuel.
	3. Overheating	Check cooling system. Remove weeds from water intake. Check alternator belt tension. Readjust rudder trim tab.
	4. Boat overloaded	Reduce load.
	5. Boat trim	Distribute boat load evenly.
	6. Improper propeller selection	Select proper propeller pitch and diameter. (See chart in owner's manual).
	7. Excessive bilge water	Check for excessive water, drain bilge.

8. Boat hull condition Clean if growth is present.

6. Electrical System

Your Cobalt electrical system was designed for easy maintenance. Most wiring and looms are readily accessible. Looms from the control panel rest in a channel under the starboard deck.

7. Wiring Diagrams

The diagrams on the following pages outline the electrical system. It is recommended that you let your Cobalt Dealer service any difficulties.

8. Circuit Breakers

All electrical standard equipment devices are controlled with circuit breakers. These breakers will activate if overloaded and cut power to the switch. To restore power, simply push the breakers in and release. (Breakers do not require fuse replacement).

9. Lighting/Bulb Replacement

External Lights

Bow Light Bulb — Perko Fig. 71 12V 10W

Aft Nav. Light Bulb — #90 12V(CS23)

Internal Lights

Under Dash Panel Courtesy Light — #GE1004MB1

Cuddy Cabin Indirect Lights — #211 12V 12CP

Cuddy Cabin Reading Lights — #1141 12V

Cockpit Courtesy Lights — #211 12V 12CP

Instrument Lights

Tachometer(s) — #GE1815

Speedometer — #GE161

Ammeter(s) — #GE161

Oil Pressure(s) — #GE161

Fuel — #GE161

Trim(s) — #GE161

Temperature(s) — #GE161

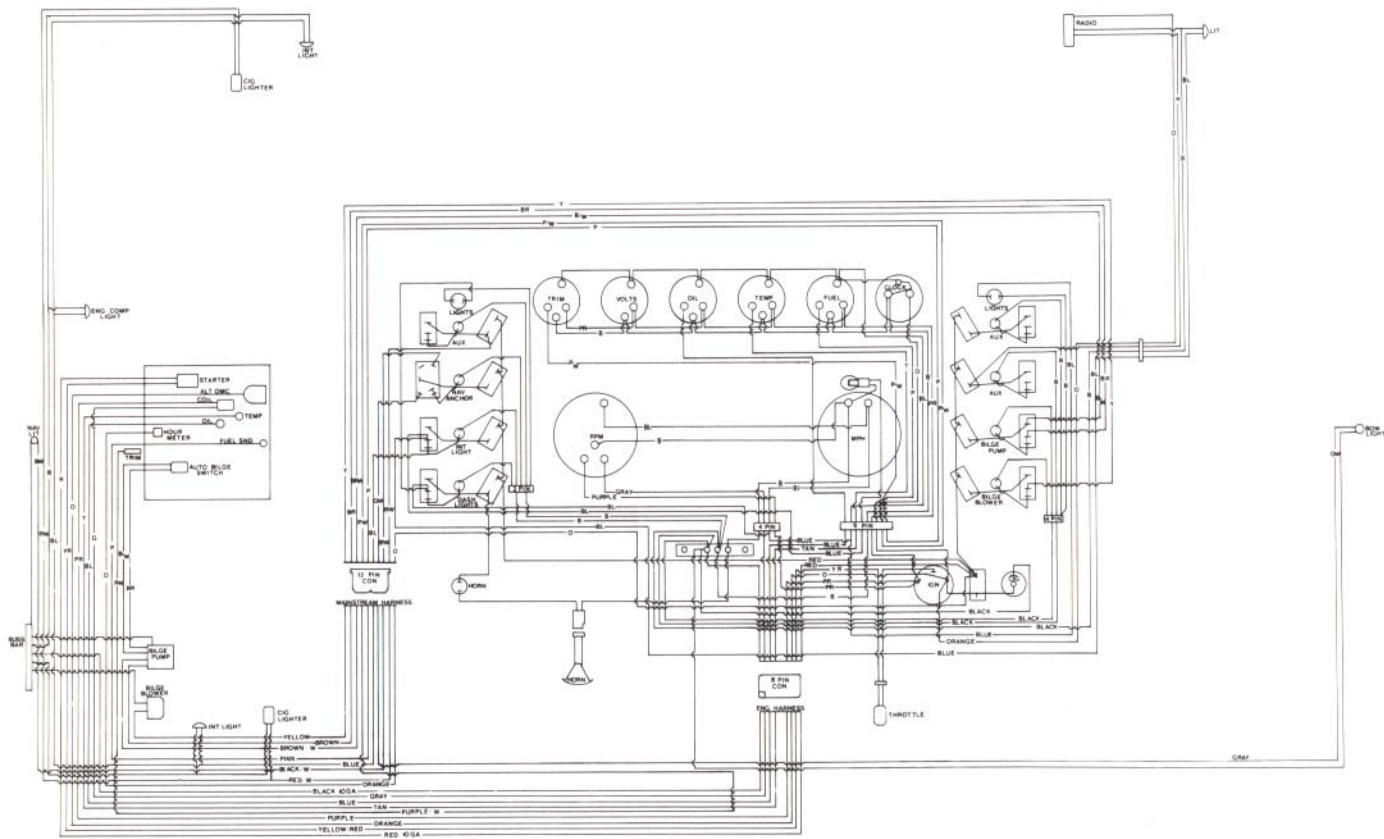

17BR AND CONDESA SINGLE

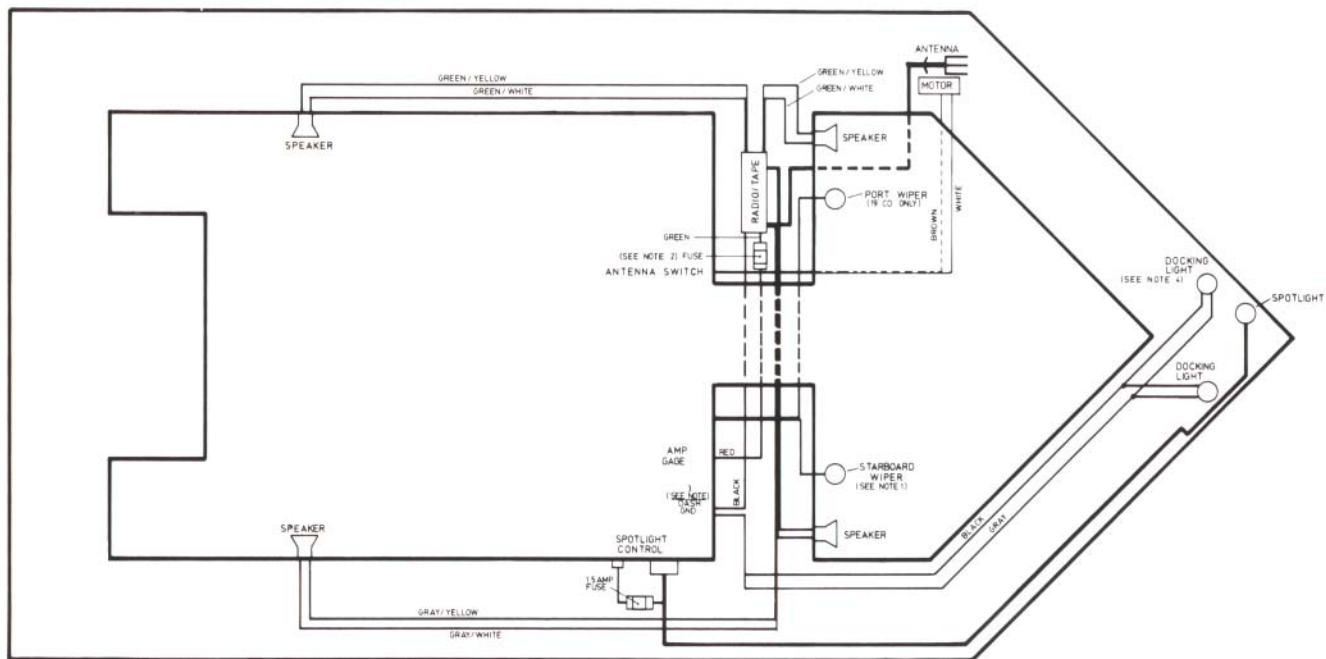

NOTE

- 1 SEE WIPER MOTOR WIRING DIAGRAM & DASH WIRING DIAGRAM FOR WIPER INTERCONNECTION
- 2 FUSE LOCATED BEHIND GLOVE BOX
- 3 DOCKING LIGHTS NEED A 20 AMP CIRCUIT BREAKER INSTALLED ON A DIX SWITCH
- 4 AVAILABLE ONLY ON THE 19 D.V.
- 5 ----- WIRING RUNS UNDER DECK

**18V, & 19BR,
OPTIONAL EQUIPMENT**

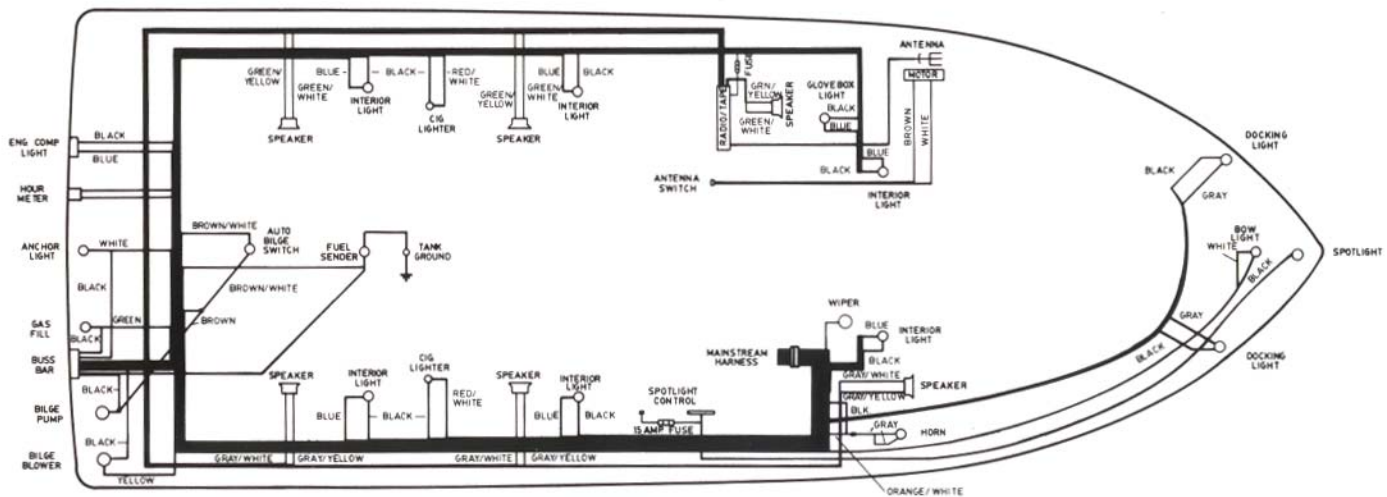

21 BR STANDARD & OPTIONAL EQUIPMENT

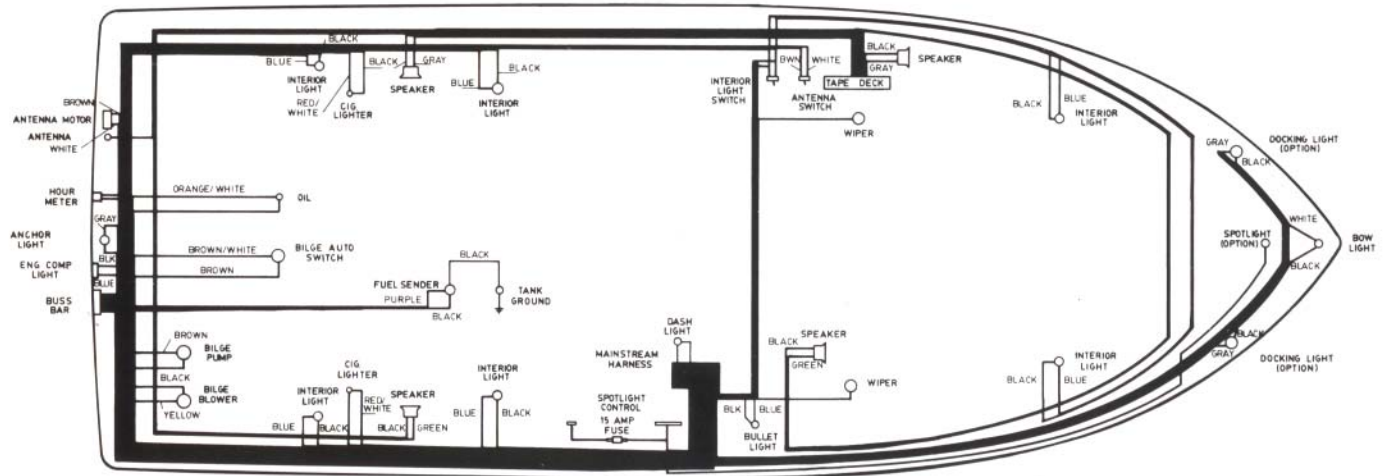

21CC STANDARD & OPTIONAL EQUIPMENT

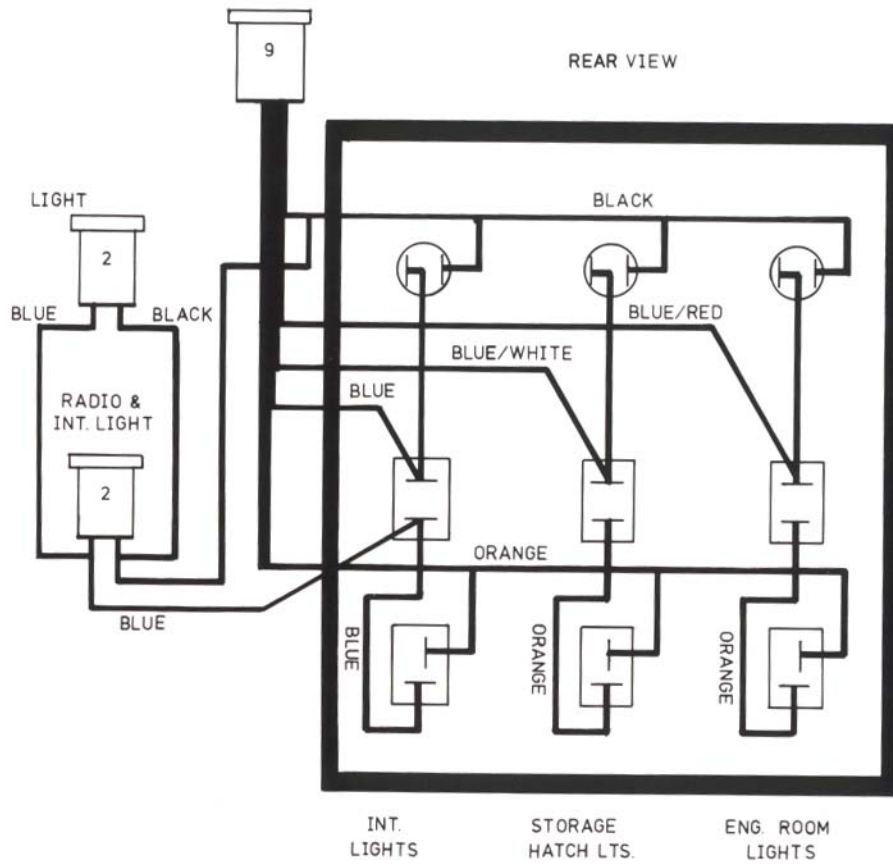

CON. CUDDY PANEL

NOTE:

THIS DIAG. PERTAINS TO ALL MODELS AFTER 1975

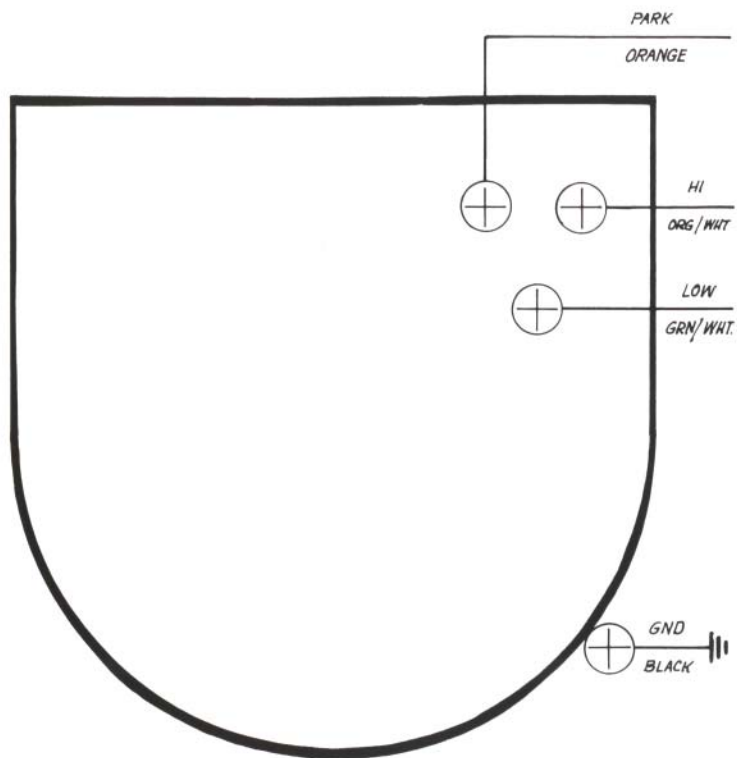

WIPER MOTOR WIRING DIAG.

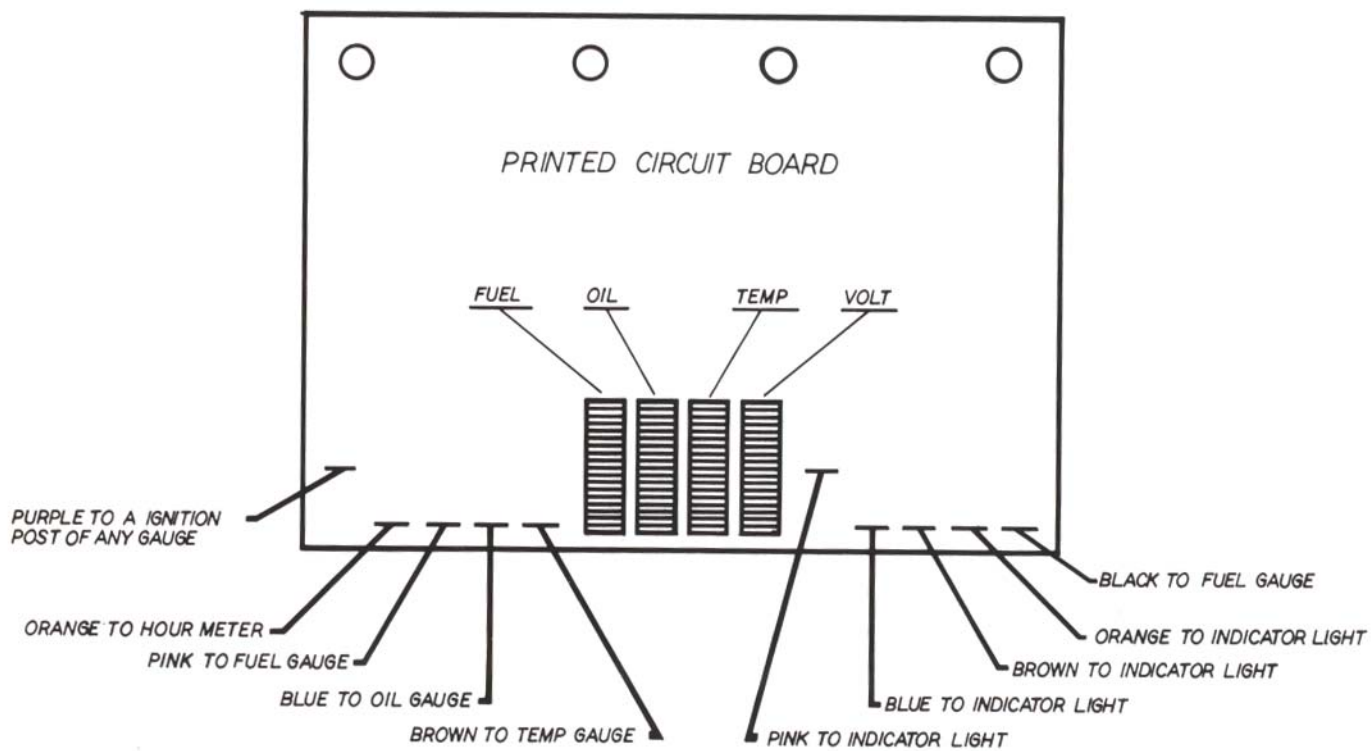

10. Specifications

	17BR	18DV	19BR	21BR	21CC	Condesa Single	Condesa Twin	CS23 Single	CS23 Twin	Condurre 223
Hull Design	DV 20°	DV 24°	DV 24°	DV 20°	DV 20°	DV 24°	DV 24°	DV 24°	DV 24°	DV 20°
Centerline	17'0"	18'2"	19'0"	21'1"	21'1"	22'7"	22'7"	22'7"	22'7"	22'3"
Beam	88 ¹ / ₂ "	88 ¹ / ₂ "	91"	96"	96"	96"	96"	96"	96"	96"
Draft	17"	17 ¹ / ₂ "	17"	17"	17"	18"	21"	17 ¹ / ₂ "	20 ¹ / ₂ "	17"
Freeboard, Forward	34"	30"	30"	38"	38"	42"	42"	35"	35"	35"
Freeboard, Aft	27"	27"	27"	35"	35"	39"	39"	35"	35"	24"
Transom Height	44"	36"	40"	42"	42"	48"	48"	48"	48"	40"
Average Weight	2475	2700	2850	3600	3700	4200	5200	3900	4900	3225
Fuel Capacity	31	38	48	60	60	98	98	71	71	41

Engines:

OMC 175	Chevrolet V-6	262 cu. in.	(2 BBL)
OMC 205	Chevrolet V-6	262 cu. in.	(4 BBL)
OMC 230	Chevrolet V-8	305 cu. in.	(4 BBL)
OMC 260	Chevrolet V-8	350 cu. in.	(4 BBL)
MER 185	Chevrolet V-6	262 cu. in.	(2 BBL)
MER 205	Chevrolet V-6	262 cu. in.	(4 BBL)
MER 190	Mercury 4	224 cu. in.	(4 BBL)
MER 200	Chevrolet V-8	305 cu. in.	(2 BBL)
MER 230	Chevrolet V-8	305 cu. in.	(4 BBL)
MER 260	Chevrolet V-8	350 cu. in.	(4 BBL)

Batteries:

Sears DieHard 81 Amp 12V DC, 500 Amp Cold Cranking Power

FIVE YEAR LIMITED WARRANTY ON HULL AND DECK, TWO YEAR LIMITED WARRANTY ON MANY COMPONENT PARTS

Cobalt Boats warrants, to the original retail purchaser only, the hull and deck of each new Cobalt Boat to be free from structural defects in material and workmanship under normal recommended use for a period of five (5) years from the date of delivery to the original retail purchaser.

Cobalt Boats warrants, to the original retail purchaser only, many component parts, other than the hull and deck, of each new Cobalt Boat to be free from structural defects in material and workmanship under normal recommended use for a period of two (2) years from date of delivery to the original retail purchaser.

This warranty does not apply to (1) engines, boat drives, controls, batteries, or other equipment or accessories manufactured by manufacturers other than Cobalt Boats, which are separately warranted by such other manufacturers (appropriate adjustments therefore being provided by their respective manufacturers); (2) Engines or accessories installed by others; (3) windshield leakage, upholstery damage, carpet damage and gelcoat damage; (4) the blistering of gelcoat finishes; and (5) any Cobalt Boat which has been altered, subjected to misuse, negligence or accident, or used for racing or commercial purposes.

Cobalt Boats shall not be liable for special or consequential damages such as, but not limited to, damage for cost of replacement goods or damages for claims of third parties against the purchaser, or damages for loss of profits.

During the applicable warranty period, as set forth above, warranty repairs will be made without charge by Cobalt Boats at its plant in Neodesha, Kansas, or, at the option of Cobalt Boats, by an authorized Cobalt Boats dealer, designated by Cobalt Boats. Transportation to and from the Cobalt Boats plant in Neodesha, Kansas, or to and from our authorized Cobalt Boats Dealer, will be at the owner's expense. All warranty repairs will be subject to the authorization of factory-trained personnel of Cobalt Boats, whose decisions will be final.

To validate this warranty, the warranty registration card must be returned to Cobalt Boats within ten (10) days after purchase by original retail purchaser. Notification of any warranty claim, arising within the applicable warranty period, as set forth above, must be made in writing by the original retail purchaser or by an authorized Cobalt Boats dealer to Cobalt Boats within thirty (30) days after the discovery of the alleged basis for any warranty claim.

In no event shall the liability of Cobalt Boats under this warranty exceed the purchase price of the specific item or items to which such warranty relates.

This warranty constitutes the only express warranty covering new Cobalt Boats. Any implied warranty, which may be determined to pertain to any component of a new Cobalt Boats, is limited to five (5) years on the hull and deck and limited to two (2) years on all component parts covered by the express warranty, as set forth above, except in those states which have other limitations on the duration of an implied warranty.

This warranty gives the original retail purchaser specific rights and remedies. In addition, the original retail purchaser may also have other rights and remedies which vary from state to state.

COBALT BOATS
NEODESHA, KANSAS