



COBALT



*Owner's Manual*

360 Performance Cruiser

### **We Wish You Safe and Happy Boating!**

Your Cobalt 360 Performance Cruiser was built to meet or exceed all applicable boat building standards at the time of manufacture. Your Cobalt boat was inspected and certified prior to introduction, and periodic inspections of this model are conducted in-plant to ensure continued compliance. Cobalt is affiliated with the following organizations for your safety and pleasure.

The American Boat and Yacht Council, Inc. (ABYC) is an independent organization dedicated to developing and maintaining the highest level of marine equipment safety standards for U.S. boat manufacturers. Working closely with the U.S. Coast Guard (USCG) and other authorities, the ABYC reviews marine equipment and systems, including electrical systems, ventilation, steering, flotation, load capacity, fuel system and others that may have an impact on your safety.

The National Marine Manufacturers Association (NMMA) is an independent organization involved in a wide range of activities aimed toward the promotion and improvement of all aspects of boating. Members include manufacturers of boats, engines and marine equipment of all types.

One division of the NMMA provides an inspection and certification program to members. Inspections are performed to the rigid and detailed standards of the USCG and ABYC. Certification requires compliance with all applicable standards and recommendations.

## Welcome

Dear New Cobalt Owner,

From all of us at the factory and from your Cobalt Dealer, thank you for purchasing a Cobalt 360 Performance Cruiser. We greatly appreciate your business and look forward to a long and enjoyable relationship with you as part of the Cobalt family.

This manual is designed to help you maximize the enjoyment of your Cobalt boat, and to acquaint you with proper operation, care, storage and maintenance of your investment.

Even if you're a seasoned boater and have previously owned a Cobalt, I recommend you take time to read through this Owner's manual. As you read this manual, please remember that "common sense" and "courtesy" are the most valuable traits you can have to fully enjoy safe boating. It is also to your personal advantage to become well acquainted with the rules and general "know how" of boating.

For service and for assistance contact your Cobalt dealer. The dealership staff will be happy to answer questions concerning maintenance, warranty or any other operational questions you may have about your Cobalt.

All the best in boating,



Paul St. Clair, Chairman and C.E.O.

## TABLE OF CONTENTS

<b>Section 1 – General Information</b>	
Cobalt Warranty . . . . .	1-3
Owner Responsibility/Warranty Procedure . . . . .	1-4
Features/Construction . . . . .	1-4
Boating Terminology . . . . .	1-5
Specifications . . . . .	1-5
Warning Labels . . . . .	1-6
Standard Equipment . . . . .	1-7
Optional Equipment . . . . .	1-8
Publications . . . . .	1-8
Nautical Terms . . . . .	1-9
Symbols . . . . .	1-12
<b>Section 2 – Responsibilities and Safety</b>	
Owner/Operator Responsibilities . . . . .	2-1
Safety . . . . .	2-9
Navigation . . . . .	2-15
<b>Section 3 – Operating Information</b>	
Precautions . . . . .	3-1
First Time Operation . . . . .	3-2
Getting Underway . . . . .	3-4
<b>Section 4 – Systems</b>	
Machinery Arrangement . . . . .	4-1
Dimensions . . . . .	4-3
Doors, Hatches and Stowage . . . . .	4-4
Deck Plates/Thru-Hulls . . . . .	4-5
Deck Occupancy . . . . .	4-6
Bilge . . . . .	4-6
Fuel . . . . .	4-7
Marine Toilet . . . . .	4-8
Piping . . . . .	4-10
Cabin Distribution Panel . . . . .	4-14
DC Electrical . . . . .	4-15
AC Electrical . . . . .	4-15
Tie Down Locations . . . . .	4-19
Fire Suppression Equipment . . . . .	4-20
<b>Section 5 – Troubleshooting/Maintenance</b>	
Scheduled Maintenance and Service . . . . .	5-1
Unscheduled Maintenance . . . . .	5-3
Interior/Exterior Care . . . . .	5-4
Corrosion Protection . . . . .	5-8
Lifting the Boat . . . . .	5-9
Storage/Winterization . . . . .	5-9
Troubleshooting . . . . .	5-10
<b>Section 6 – Checklist, Forms and Index</b>	
Operation Quick Reference . . . . .	6-1
Service Log . . . . .	6-3
Fuel Log . . . . .	6-4
Float Plan . . . . .	6-5
Alphabetical Index . . . . .	6-6
Useful Information . . . . .	6-7

## COBALT WARRANTY

Ten-year limited transferable warranty on hull and deck structure, two-year limited transferable warranty on other component parts.

Cobalt Boats warrants the hull and deck, including floor, stringers, motor mounts, transom and deck/hull joints of each new Cobalt boat to be free from structural defects in material and workmanship under normal recommended use for a period of ten (10) years from the date of delivery to the original retail purchaser.

Cobalt Boats warrants the gelcoat finish, upholstery, components not having their own warranty and all components manufactured by Cobalt Boats, other than the hull and deck, of each new Cobalt boat to be free from structural defects in material and workmanship under normal recommended use for a period of two (2) years from the date of delivery to the original retail purchaser.

This warranty does not apply to (1) engines, outdrives, controls, batteries, or other equipment or accessories which are separately warranted by the manufacturers thereof (appropriate adjustments therefore being provided by the respective manufacturer); (2) engines or accessories installed by persons or parties other than Cobalt Boats; (3) windshield leakage, upholstery damage, carpet damage and gelcoat damage; and (4) any Cobalt boat which has been altered, subject to misuse, negligence or accident, or used for racing or commercial purposes.

The rights and benefits granted under this warranty to the original retail purchaser of a new Cobalt boat shall extend to any owner of such Cobalt boat during the applicable warranty period, commencing with the date of delivery to the original retail purchaser, as set forth herein, provided this warranty is validated by such owner, as set forth herein. In no event shall the owner of any Cobalt boat, covered by this warranty, have any rights or benefits under this warranty which are greater than the rights and benefits which would have been available under this warranty to the original retail purchaser of such Cobalt boat had the original retail purchaser remained the owner of such Cobalt boat.

Cobalt Boats shall not be liable for special or consequential damages, such as, but not limited to, damages for cost of replacement goods, or damages for claims of third parties against the purchaser, or damages for loss of profits.

To validate this warranty, the original retail purchaser must return the warranty registration card to Cobalt Boats within ten (10) days after purchase of any Cobalt boat covered by this warranty, and any subsequent owner of a Cobalt boat during the applicable warranty period must give written notice of acquisition of a Cobalt boat to Cobalt Boats within ten (10) days after such purchase.

Notification of any warranty claim, arising within the applicable warranty period, as set forth above, must be made in writing by the owner of the Cobalt boat or by an authorized Cobalt Boat dealer to Cobalt Boats within thirty (30) days after the discovery of the alleged basis for any warranty claim.

During the applicable warranty period, as set forth above, warranty repairs shall be made without charge by an authorized Cobalt Boats dealer or, at the option of Cobalt Boats, by Cobalt Boats at its plant in Neodesha, Kansas. All warranty repairs shall be subject to the authorization of factory-trained personnel of Cobalt boats, whose decision will be final. Transportation to and from an authorized Cobalt Boat dealer, and/or to and from the Cobalt Boat plant in Neodesha, Kansas, for warranty repairs, shall be at the owner's expense.

This warranty constitutes the only express warranty covering a new Cobalt boat. Any implied warranty, which may be determined to pertain to any component of a new Cobalt boat, is limited to ten (10) years on the hull and deck structure, and limited to two (2) years on all other component parts covered by the express warranty as set forth above, except in those states which have other limitations on the duration of an implied warranty.

This warranty gives you specific rights and remedies. In addition, you may also have other rights and remedies which vary from state to state.

## OWNER RESPONSIBILITY/ WARRANTY PROCEDURE

### Before Operating

Before operating your new Cobalt, it is necessary you read and understand this manual. Also, take the time to read the other component manuals supplied to you in your owner's packet.

### Warranty Service Requirements

All Cobalt warranty service must be completed by an authorized Cobalt dealer. If you are not able to return your boat to your selling dealership, you must contact him so he may assist you in coordinating the warranty repairs. Any claims against Cobalt Boats without prior approval from Cobalt Boats on repairs completed by a non-authorized dealership may be denied.

### Extended Powertrain Warranty

Your Cobalt warranty includes an Extended Limited Powertrain Warranty. Your dealer submitted the necessary forms to implement this warranty. Please read the extended warranty manual supplied to you by Passport Premiere.

It is important you have your Cobalt serviced per the engine manufacturer's recommended instructions. You must keep, in your possession, records of all service performed should the extended powertrain warranty be needed. This is to prove the required maintenance has been performed. Be sure to collect receipts for work performed and make an entry in the Service Log in the back of this manual.

If you have any questions referencing your Extended Powertrain warranty, please contact your Cobalt dealer.

### If You Sell Your Cobalt

Your warranties are transferable. If you sell your Cobalt to anyone other than an authorized Cobalt dealer, please call Cobalt Boats for the appropriate warranty transfer information (800-468-5764 or 620-325-2653). If the proper transfer procedures are not followed, future warranty may be denied.

### NMMA Certification

Cobalt is a member of the National Marine Manufacturers Association (NMMA). This independent organization's members include boat, engine and marine equipment manufacturers that are focused on the improvement and safety of boating.

Your new Cobalt boat is NMMA certified. An NMMA certification not only satisfies the U. S. Coast Guard (USCG) regulations but also the more rigorous equipment and system standards based on those established by the American Boat and Yacht Council, Inc. (ABYC). Your Formula meets or exceeds NMMA safety-based certifications.

## FEATURES/CONSTRUCTION

### Amenities

Your Cobalt 360 Performance Cruiser combines the amenities of a weekender with the performance of a sport boat. The 360 incorporates classic styling with the long, clean lines that have defined Cobalt design for 30 years.

Standard cruiser features include two berths; a galley with sink, stove, refrigerator/freezer, microwave and storage; head with shower, icemaker and a state-of-the-art entertainment system.

Performance features include a hand-laid reinforced Kevlar with an all-fiberglass stringer system and AME 1000 vinylester resins used on the deck and hull for superior strength, toughness and weight savings. Twin engine power options up to 500 horsepower and a 20° deadrise make the 360 one of the fastest, driest boats in its class.

### Construction Standards/Certifications

A Warranty Statement explaining terms and conditions is supplied in this section. Please familiarize yourself with this statement. Failure to follow operating instructions and proper maintenance can void the warranty.

Construction Standards detailing industry standards followed in building your Cobalt 360 Performance Cruiser are explained in this section. Please contact your Cobalt dealer for additional construction information.

### Serial Number Locations

Your Cobalt 360 boat, its engines and propulsion units, and other equipment onboard will have a serial number for identification. It is a good practice to prepare a list of all serial number items and store it in a safe place other than onboard the boat. A page is supplied at the end of this manual for this purpose. Please refer to the equipment operator's manuals supplied in your owner's packet for location of serial numbers.

## BOATING TERMINOLOGY

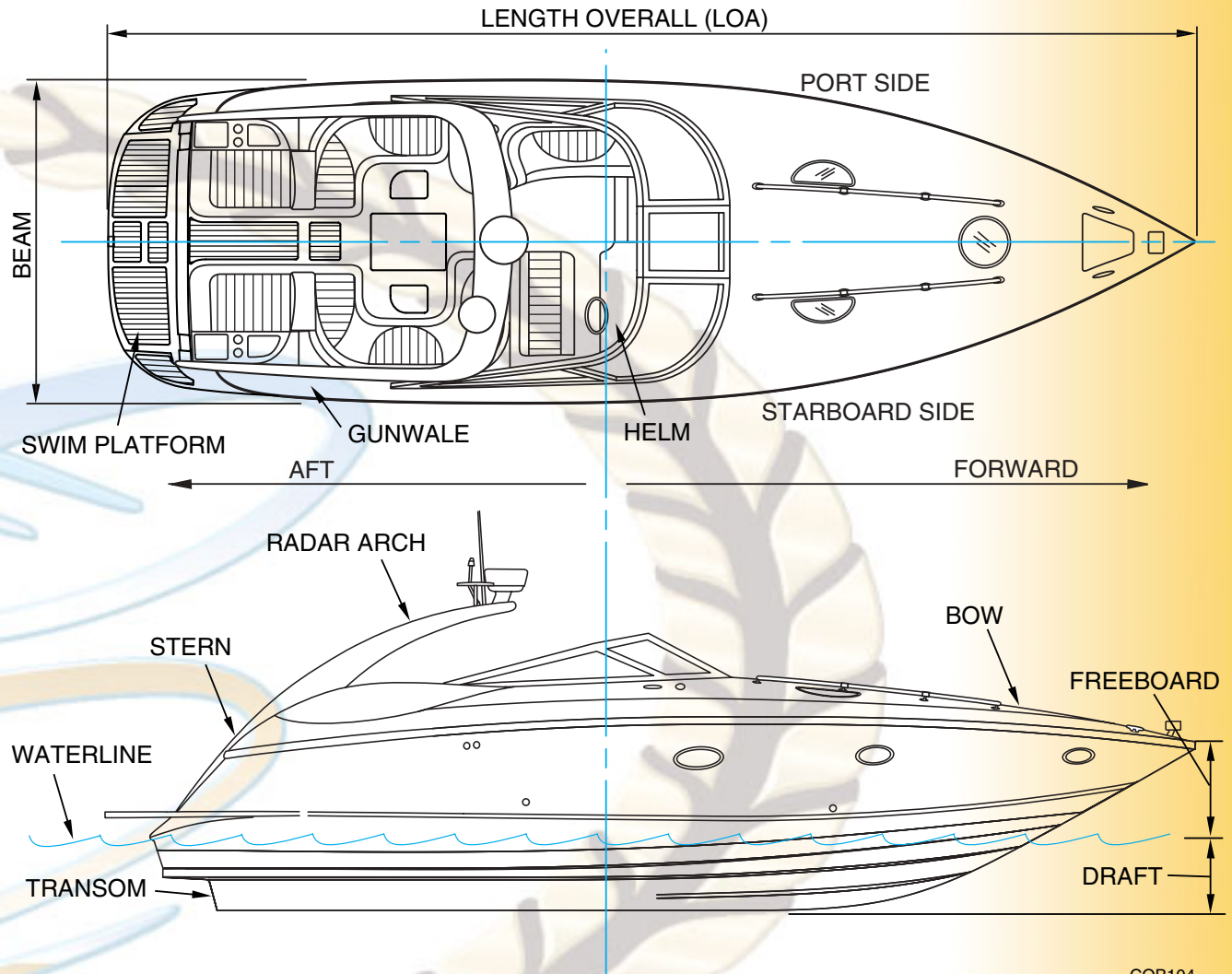

COB104

## SPECIFICATIONS

Style	Performance Cruiser	Freeboard Aft	53" (1.35 m)
Length Overall	36' 0" (11 m)	Fresh Water Capacity	35 gal (132 L)
Beam	10' 6" (3.20 m)	Waste Water Capacity	28 gal (106 L)
Dry Weight	13,710 lbs. (6,219 kg)	Capacity, weight	Yacht Certified
Deadrise	20°	Capacity, persons	Yacht Certified
Fuel Capacity	174 gal (659 L)	Bridge Clearance w/o Radar	8' 5" (2.57 m)
Draft, Drive Up	27" (69 cm)	Bridge Clearance w/ Radar	9' 6" (2.90 m)
Draft, Drive Down	42" (107 cm)	Trailing Height w/o Radar	12' 2" (3.7 m)
Freeboard Forward	52" (1.32 m)	Trailing Height w/ Radar	13' 3" (4.0 m)

# WARNING LABELS

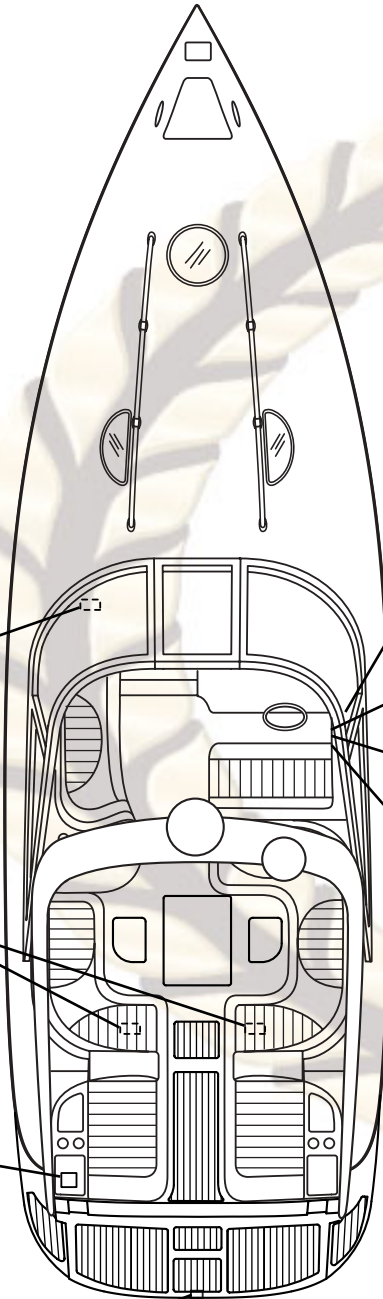

**COBALT CHECK LIST**

For maximum enjoyment and safety, check each of these items BEFORE you start your engine:

- DRAIN PLUG (securely in Place?)
- LIFE-SAVING DEVICES (One for every person on board?)
- STEERING SYSTEM (Working smoothly and properly?)
- FUEL SYSTEM (Adequate fuel? Leaks? Fumes?)
- BATTERY (Fully charged? Proper water level)
- ENGINE (In neutral?)
- CAPACITY PLATE (Are you overloaded or overpowered?)
- WEATHER CONDITIONS (Safe to go out)
- ELECTRICAL EQUIPMENT (Lights, horn, pump, etc?)
- EMERGENCY GEAR (Fire extinguisher, bailer, paddle, anchor and line, signalling device, tool kit, etc?)

**RECOMMENDED SAFETY RULES**

- REMAIN SEATED WHILE UNDERWAY
- AVOID USING REAR PAD OR SUNDECK WHILE ENGINE IS RUNNING
- DO NOT USE BOARDING LADDER WHILE ENGINE IS RUNNING
- TURN OFF ENGINE AND ALL ELECTRICAL SYSTEMS WHILE RE-FUELING
- TURN OFF ENGINE WHEN SWIMMERS ARE NEAR BOAT

**⚠ DANGER**

CARBON MONOXIDE IS COLORLESS, ODORLESS AND DANGEROUS. ALL GASOLINE POWERED ENGINES AND GENERATORS EXHAUST CARBON MONOXIDE (CO). DIRECT AND PROLONGED EXPOSURE TO CO WILL CAUSE BRAIN DAMAGE OR DEATH. SIGNS OF EXPOSURE TO CO INCLUDE NAUSEA, DIZZINESS AND DROWSINESS. Keep Cabin and cockpit Areas Well Ventilated. Avoid Blockage of Exhaust Outlets. See Owner's Manual for More Details.

**⚠ DANGER**

CARBON MONOXIDE IS COLORLESS, ODORLESS AND DANGEROUS. ALL GASOLINE POWERED ENGINES AND GENERATORS EXHAUST CARBON MONOXIDE (CO). DIRECT AND PROLONGED EXPOSURE TO CO WILL CAUSE BRAIN DAMAGE OR DEATH. SIGNS OF EXPOSURE TO CO INCLUDE NAUSEA, DIZZINESS AND DROWSINESS. Keep Cabin and cockpit Areas Well Ventilated. Avoid Blockage of Exhaust Outlets. See Owner's Manual for More Details.

**WARNING**

Gasoline vapors can explode

Before starting engine:

- Check engine compartment for gasoline or vapors.
- Operate blower for 4 minutes.

Run blower below cruising speed

**WARNING**

LEAKING FUEL IS A FIRE AND EXPLOSION HAZARD. INSPECT SYSTEM REGULARLY. EXAMINE FUEL SYSTEM FOR LEAKS OR CORROSION AT LEAST ANNUALLY.

© NMMA 1990/NO.200

**⚠ WARNING**

To minimize shock and fire hazards:

- (1) Turn odd the boat's shore connection switch before connecting or disconnecting shore cable
- (2) Connect shore power cable at the boat first.
- (3) If polarity warning indicator is activated, immediately disconnect cable.
- (4) Disconnect shore power cable at shore outlet first.
- (5) Close shore power inlet cover tightly.

**DO NOT ALTER SHORE POWER CABLE CONNECTORS**

**NMMA**

**YACHT CERTIFICATION**

DESIGN COMPLIANCE WITH NMMA REQUIREMENTS IN EFFECT ON THE DATE OF CERTIFICATION IS VERIFIED. MANUFACTURER RESPONSIBLE FOR PRODUCTION CONTROL.

NATIONAL MARINE MANUFACTURERS ASSOCIATION  
THIS BOAT COMPLIES WITH U.S. COAST GUARD SAFETY STANDARDS IN EFFECT ON THE DATE OF CERTIFICATION  
FBRGLS ENG INC, COBALT BT NEODESHA, KS

**⚠ WARNING**

PROPELLER LOCATED BEHIND THIS BOAT. CONTACT MAY CAUSE SEVERE INJURY OR FATALITY. DO NOT APPROACH OR USE LADDER AND PLATFORM WHEN THE ENGINE IS RUNNING.

COB011

## STANDARD EQUIPMENT

The following is a list of standard equipment furnished with your Cobalt 360 boat:

### Structure/Safety/Performance

5 yr Powertrain Warranty  
10 yr Hull/Deck Warranty  
Battery Charger  
Battery Switch (Three)  
Fire Extinguisher (Portable and Fixed System)  
Fiberglass Stringer System  
Carbon Monoxide Detectors (2)  
Ignition Safety Switch  
Shore Power (Dual 30 amp, 110 volt)  
Stainless Windshield Braces  
Tool Kit  
Trim Tabs (Merc K-Plane)  
Yacht Certification

### Canvas

Bimini Top  
Bimini Enclosure

### Dash

Compass  
Depth Gauge  
Air/Water Temperature Gauge  
Leather Steering Wheel  
Zero Effort Engine Controls  
12-Volt Accessory Outlet  
Tilt Steering Wheel  
Hour Meters  
Waterfall Wood Dash Panels  
Trim Tab Indicator System  
Windshield Wiper, Driver

### Stereo/Video

Cabin Entertainment System – TV, DVD, Stereo,  
Subwoofer, CD Changer  
Driver Remote Stereo Control

### Exterior

Anchor Windlass with Delta Anchor  
Bow Scuff Plate  
Concealed Boarding Ladder  
Transom Storage  
Stainless Steel Foredeck Rail  
Radar Arch

### Interior

Air Compressor  
Air Conditioning Unit, 10 kW  
Cabin Door with Screen  
Cabin Table  
Cockpit Dinette Table  
Corian Wet Bar with Hot/Cold Sink  
DuPont Zodiaq® Galley Top  
Fiberglass Head Unit with Shower  
Fiberglass Liner Deck  
Icemaker  
Microwave Unit, 110 Volt  
Refrigerator/Freezer  
Removable Cockpit Carpet, 40 oz.  
Stainless Steel Windshield Frame  
Stove, 110 Volt  
Transom Walk-Thru Gate  
VacuFlush Head System  
Water Heater (110 Volt with Exchanger)  
110 Volt Convenience Outlet

## OPTIONAL EQUIPMENT

Most optional equipment can only be factory installed at the time of manufacture. For this reason, options cannot be retrofitted. The following is a list of available optional equipment for your Cobalt 360 Performance Cruiser:

### Structure/Safety/Performance

Captain's Call Exhaust  
Electronic Shift Controls  
Generator, Gas (4kW) with Sound Shield  
Generator, Diesel (4kW) with Sound Shield  
Stainless Prop Exchange (Single)  
Thru-Hull Exhaust  
Inverter  
CE Approved Requirements Available for European Markets

### Canvas

Cockpit Tonneau  
Mooring Cover, Sharkskin

### Dash

GPS Unit, In-Dash  
Radar/GPS Unit (In-Dash)  
VHF Radio

### Stereo/Video

Video Cassette Player  
Transom Speaker Package  
Midberth TV Package

### Exterior

10 inch Bow Rail  
Docking Lights  
Foredeck Sunpad  
Spotlight  
Transom Shower  
Teak Swim Platform

### Interior

Aft Walk-thru Filler Cushion  
Spectral Frost Carpet Option  
Admiral Blue Carpet Option  
VacuFlush Toilet w/Macerator

## PUBLICATIONS

Your owner's packet includes information about onboard systems and equipment furnished by suppliers other than Cobalt Boats. Please refer to these manufacturer's manuals for additional operation and maintenance instructions not covered in this manual.

## NAUTICAL TERMS

**ABOARD** – On or in the boat.

**ABYC** – American Boat and Yacht Council, Inc.

**AFLOAT** – On the water.

**AFT** – Toward the rear or stern of the boat.

**AGROUND** – Touching bottom.

**AMIDSHIP** – Center or middle of the boat.

**ANCHOR** – (1) An iron casting shaped to grip the lake bottom to hold the boat. (2) The act of setting the anchor.

**ASHORE** – On the shore.

**ASTERN** – Toward the stern.

**BAIL** – To remove water from the bottom of the boat with a pump, bucket, sponge, etc.

**BEAM** – The widest point on the boat.

**BEARING** – Relative position or direction of an object from the boat.

**BILGE** – The lowest interior section of the boat hull.

**BOARDING** – To enter the boat.

**BOUNDARY WATERS** – A body of water between two areas of jurisdiction; i.e., a river between two states.

**BOW** – The front of the boat.

**BULKHEAD** – Vertical partition (wall) in a boat.

**BUNKS** – Carpeted trailer hull supports.

**BURDENED BOAT** – Term for the boat that must “give-way” to boats with the right-of-way.

**CAPACITY PLATE** – A plate that provides maximum weight capacity and engine horsepower rating information. It is located in full view of the helm.

**CAPSIZE** – To turn over.

**CAST-OFF** – To unfasten mooring lines in preparation for departure.

**CENTER LINE** – A lengthwise imaginary line which runs fore and aft with the boat’s keel.

**CHINE** – The point on a boat where the side intersects (meets) the bottom.

**CLEAT** – A deck fitting with ears to which lines are fastened.

**CONSOLE** – Also called helm. The steering wheel area of the boat.

**CRANKING BATTERY** – The main battery used for engine starting and electrical circuits.

**CURRENT** – Water moving in a horizontal direction.

**DECK** – The open surface on the boat where the passengers walk.

**DEEP CYCLE BATTERIES** – Special long-running batteries which can be repeatedly discharged and recharged without significant loss of power.

**DOLLY WHEEL** – A rolling jack assembly at the front of the trailer used for positioning the coupler during trailer hookup.

**DRAFT** – The depth of the boat below the water line, measured vertically to the lowest part of the hull.

**ELECTROLYSIS** – The break-up of metals due to the effects of galvanic corrosion.

**EPIRB** – Emergency Position Indicating Radio Beacon.

**FATHOM** – Unit of depth or measure; 1 fathom equals 6 feet.

**FENDERS** – Objects placed alongside the boat for cushioning. Sometimes called bumpers.

**FORE** – Toward the front or bow of the boat. Opposite of aft.

**FREEBOARD** – The distance from the water to the gunwale.

**FUEL SENDING UNIT** – The electrical device that is mounted on the outside of a built-in fuel tank and controls the dashboard fuel gauge.

**GIVE-WAY BOAT** – (1) Term for the boat that must take whatever action necessary to keep well clear of the boat with the right-of-way in meeting or crossing situations. (2) The burdened boat.

**GUNWALE** – The rail or upper edge of a boat's side.

**HEAD** – A marine toilet.

**HELM** – The steering wheel or command area.

**HULL** – The body of the boat.

**HYPOTHERMIA** – A physical condition where the body loses heat faster than it can produce it.

**IN-LINE FUSE** – A type of protective fuse located in the power wire of a direct current (DC) circuit usually near the battery.

**KEEL** – The lowest portion of the boat; extends fore and aft along the boat's bottom.

**LIST** – Leaning or tilt of a boat toward the side.

**MAKING WAY** – Making progress through the water.

**MARINE CHART** – Seagoing maps showing depths, buoys, navigation aids, etc.

**MOORING** – An anchor, chain, or similar device that holds a boat in one location.

**NAVIGATION AID** – Recognizable objects on land or sea such as buoys, towers or lights which are used to fix position to identify safe and unsafe waters.

**NMMA** – National Marine Manufacturers Association.

**NO-WAKE SPEED** – The speed at which a boat travels to produce an imperceptible wake.

**PFD** – Personal flotation device.

**PITOT TUBE** – See SPEEDOMETER PICKUP TUBE.

**PLANING HULL** – A hull designed to lift, thereby reducing friction and increasing efficiency.

**PORPOISE** – A condition in which the bow bounces up and down caused by trimming the engine too far out.

**PORT** – (1) The left side of a boat when facing the bow. (2) A destination or harbor.

**PRIVILEGED BOAT** – Term used for the boat with the right-of-way.

**RIGHT-OF-WAY** – Term for the boat that has priority in meeting or crossing situations. The stand on or privileged boat.

**RULES OF THE ROAD** – Regulations for preventing collisions on the water.

**SPEEDOMETER PICKUP TUBE** – Also called pitot tube. The plastic device that extends below the bottom of the boat. It connects to the speedometer with plastic flexible tubing.

**STAND ON BOAT** – Term for the boat that must maintain course and speed in meeting or crossing situations. The privileged boat.

**STARBOARD** – The right side of the boat when looking toward the bow.

**STERN** – The back of the boat.

**STOW** – To pack the cargo.

**SURGE BRAKES** – A type of trailer braking system designed to automatically actuate when the tow vehicle's brakes are applied.

**TRANSDUCER** – The unit that sends/receives signals for the depth sounder.

**TRANSOM** – The transverse beam across the stern.

**TRIM** – Fore to aft and side to side balance of the boat when loaded.

**UNDERWAY** – Boat in motion; i.e., not moored or anchored.

**USCG** – United States Coast Guard.

**WAKE** – The waves that a boat leaves behind when moving through the water.

**WATERWAY** – A navigable body of water.

**VISUAL DISTRESS SIGNAL** – A device used to signal the need for assistance such as flags, lights and flares.

# SYMBOLS

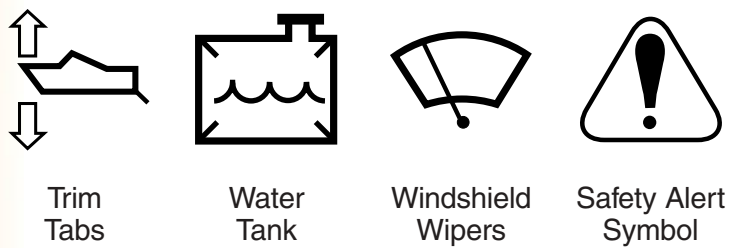
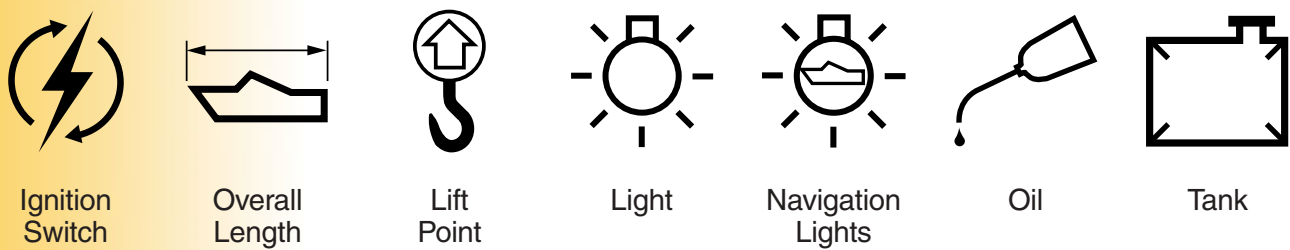
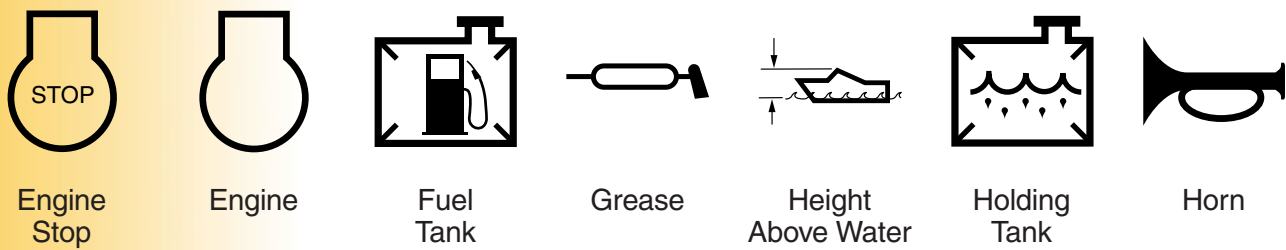
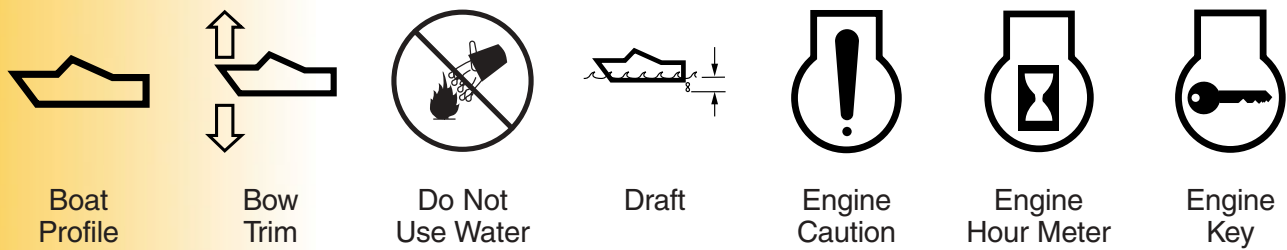
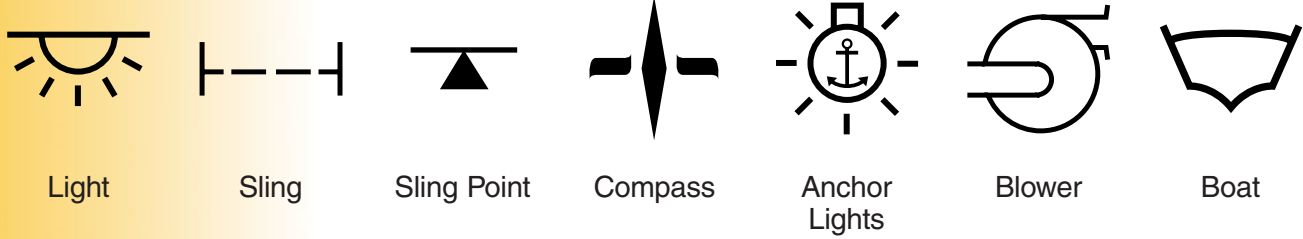

Your safety, the safety of your passengers, and other boaters are among your responsibilities as operator of this boat. Your boat must be in compliance with U.S. Coast Guard (USCG) safety equipment regulations. You should know how to react correctly to adverse weather conditions, have good navigation skills, and follow the “rules of the road” as defined by the USCG and state/county/local regulations.

## OWNER/OPERATOR RESPONSIBILITIES

At the time of delivery, the owner/operator is responsible for:

- Understanding warranty terms and conditions of both the propulsion units and boat.
- Obtaining insurance.
- Examining boat to ensure proper operation of all systems.

Before operating the boat, the owner/operator is responsible for:

- Obtaining state registration of the boat.
- Providing the proper USCG required safety equipment.
- Following proper break-in procedure for the propulsion units.
- Understanding safety information and proper operating procedures within this manual.

While operating the boat, the owner/operator is responsible for:

- Knowing that all safety equipment and personal flotation devices are in good condition and suitable for your boat and passenger load.
- Having at least one other passenger who is capable of handling the boat in an emergency.
- Following safe operating practices and the rules of the road.
- Understanding proper maintenance and knowledge of the boat’s operating systems.
- Providing safety training for the passengers.

- Avoiding use of alcohol and other drugs.
- Providing assistance to other boaters.

## Registration/Documentation

The USCG requires that all power boats operated on the navigable waters of the U. S. must be registered in the state of main use; also, many states require registration in that state whenever boating on waters within their state boundary. Contact your state boating authorities (and neighboring states) for registration information on boats and trailers. Your dealer can supply you with the appropriate forms.

## Required Safety Equipment

The Federal Boat Safety Act of 1971 (FBSA/71) established minimum safety standards for boats and associated equipment, specified by the USCG. In addition, the ABYC and the NMMA work with boat builders to develop voluntary standards that exceed base requirements.

The included safety equipment on your Cobalt meets or exceeds the standards of the USCG, ABYC and the NMMA. Some required safety equipment such as personal flotation devices are not included with your Cobalt boat. Your Cobalt dealer can help you choose the appropriate equipment.



**NOTICE: Many states’ equipment requirements go beyond USCG requirements. Contact your state boating office for further information.**

Equipment requirements for coastal and inland waters differ. Check with local authorities or the USCG for further information about coastal water requirements.

## Navigation Lights

All power boats underway between sunset and sunrise must display proper navigation lights. All boats at anchor must display a proper anchor light. Anchor light must be visible 360 degrees. Your Cobalt 360 Performance Cruiser is equipped with international navigation lights.

## Horn or Whistle

All boats over 4.8 m (16 ft) in length must be equipped with an operable horn or whistle, audible from one mile. Your Cobalt 360 Performance Cruiser is equipped with a USCG approved horn.

### Fire Extinguisher

All inboard/outboard boats must carry an appropriate portable marine type fire extinguisher in operable condition and accessible location. Your Cobalt 360 Performance Cruiser is equipped with a portable and fixed system fire extinguisher.

### Lifesaving Devices

All boats must carry one USCG approved Type I, II, or III, wearable, personal flotation device, of the proper size, for each person on board.

All boats over 4.8 m (16 ft) in length must carry one USCG approved Type IV throwable lifesaving device, such as a ring buoy or buoyant cushion. To meet requirements, each lifesaving device must have a currently legible USCG approval stamp permanently affixed.

Your Cobalt dealer can help you select appropriate PFDs and throwable lifesaving devices for your area.

### Visual Distress Signals

All boats over 4.8 m (16 ft) must have onboard day and night visual distress signals. Your Cobalt dealer can help you select appropriate visual distress signals for your area.

### Recommended Safety Equipment

In spite of all efforts to the contrary, problems or mishaps sometimes occur while boating. Stock these items listed below on your boat to help make unexpected events more manageable.

- Anchor and anchor line
- Compass
- First aid kit
- Distress signals (flag for daytime, flares for darkness)
- Flashlight and spare batteries
- Portable radio
- Cellular phone
- Sea anchor
- Binoculars
- Emergency Position Indicating Radio Beacon (EPIRB)
- Boat Hook
- Sun glasses and sun block lotion

### Recommended Spare Parts

The following list contains common spare parts you should carry onboard. Review all the equipment on your boat. Be sure to have spare parts available to maintain and make minor repairs if necessary. Refer to all operator's manuals in your owner's packet for the manufacturer's recommended spare parts.

- Lanyard for ignition safety switch
- Engine and generator oil
- Hydraulic fluid for the steering system and trim system
- Ignition keys
- Tape, tie straps and rope
- Light bulbs and fuses
- Propeller with attaching hardware

### Education Opportunities

Be boat smart from the start, take a boating safety course and get a free vessel safety check annually for your boat. For more information, contact: United States Coast Guard Auxiliary, 800-368-5647, [www.cgaux.org](http://www.cgaux.org); United States Power Squadrons, 888-FOR-USPS, [www.usps.org](http://www.usps.org).

Most boaters can enhance their enjoyment of boating experiences through increased knowledge of safe operation, navigation and regulation of pleasure boats. The following is a list of some other agencies and organizations that offer Water Safety, First Aid and CPR courses or information. To find boating safety courses in your area, call your state's local boating agency or the USCG boating safety course line at 800-336-2628 (800-245-2628 in Virginia).

- American Red Cross
- U.S. Coast Guard Auxiliary
- U.S. Power Squadrons
- State Boating Offices
- Canadian Power and Sail Squadrons
- Yacht Clubs

## **Insurance**

You must get insurance before operating your new boat. Insurance for loss by fire, theft or other causes, or liability protection against accidents is a must for responsible boaters. The boat owner is legally responsible for any damage or injury caused when he, or someone else operating the boat, is involved in an accident. Many states have laws detailing minimum insurance needs. Your insurance agent or your dealer may be able to supply you with more information.

## **Boat Theory**

The following information briefly explains main system theory.

### **Remote Control System**

The shift levers and throttle levers are connected to the engine and propulsion units by mechanical push/pull cables. The shift lever controls the direction of the boat, and the throttle lever controls the speed of the boat.

### **Steering System**

The steering wheel (helm) is connected to a hydraulic cylinder. As you turn the helm, hydraulic fluid directs movement of a steering cylinder. The cylinder is mechanically connected to the drive units.

### **Fuel System**

The fuel system consists of two permanent tanks with separate vent, level sensor and fuel fillers. Each tank has an anti-siphon valve to prevent fuel from accumulating in the bilge if a hose should break.

The system also includes two fuel tank selection valves for individual tank selection. The selection valve allows each engine to receive fuel from either the starboard or port fuel tanks.

### **Ventilation System**

The engine compartment ventilation system consists of switch operated blowers installed within the engine compartment. When activated, the blowers exhaust dangerous fumes and intake fresh air through vents. It is recommended to run the blowers for 4 minutes before starting the engines.

## **Electrical System**

Your Cobalt 360 boat is equipped with two electrical systems. The direct current (DC) system is battery powered and supplies electricity to all the boat's lights, pumps, blowers, refrigerator and engine ignition. An optional inverter converts 12 VDC into 120 VAC for limited uses. The alternating current (AC) system is shore power, generator or inverter powered, and supplies electricity to electrical outlets, stove, icemaker, water heater, air conditioning, microwave and battery charger.

## **Cooling System**

Your engines and generator are cooled by the continuous intake of raw water through independent water intakes. The water flows to water pumps on the engines or generator for circulation around internal components.

The engine water intakes and outlets are located in the drive units. The generator water intake is in the bottom of the hull and the exhaust is on the starboard side above the water line. The air conditioner water intake is in the bottom of the hull and the exit is in the starboard bow area.

Your Cobalt may be equipped with an optional self-contained cooling system that pumps a mixture of fresh water and anti-freeze through a large heat exchanger to reduce temperatures. Raw water is circulated through the other side of the heat exchanger to dissipate heat absorbed by the coolant mixture.

## **Exhaust System**

The engine and generator exhaust systems remove the gases produced by the running engine and vents them away from the boat. Engine exhaust is usually vented through the drive unit propeller but may be diverted through the transom with the optional captain's call exhaust system. Engine and generator cooling water are removed along with the exhaust gases.

## **Lubrication System**

Your engines and the optional generator use a pressurized continuous loop lubrication system that must be periodically serviced in accordance with the manufacturer's recommendations. The engines have electrical transducer units to provide oil pressure signals to gauges at the helm. Full oil pressure must be available for proper lubrication, so monitoring the gauges is important, especially when operating at cruising speeds and above.

## Seaworthiness Inspection

### WARNING

**Do not operate the boat if any problem is found during this inspection. A problem could lead to an accident during the outing causing severe injury or death. Problems found during this inspection should be handled by your Cobalt dealer.**

The following checks are essential to safe boating and must be performed before starting the engines. Get into the habit of performing these checks in the same order each time so that it becomes routine.

- Check the weather report, wind and water conditions.
- Check that required safety equipment is onboard.
- Check that fire extinguisher(s) is fully charged.
- Check that bilge drain plug is properly installed.
- Check that no fuel, oil or water is leaking or has leaked into the bilge compartment.
- Check all hoses and connections for leakage and damage.
- Check that all batteries are fully charged and have the proper level.
- Check electrical circuits (lights, pumps, horn, etc.) for proper operation.
- Check that steering system operates properly.
- Be sure the boat is not overloaded.
- Check that all maintenance has been performed.

## Operation Checklist

While operating your boat, frequently check that the control and steering system continue to operate smoothly. Monitor your gauges for signs of abnormal behavior. Beware of any excessive vibration. Refer to **Before Starting Checklist**, in **Section 3**.

## Environmental Considerations

As a boater, you already appreciate nature's beauty and the peace of the great outdoors. It is a boater's responsibility to protect the natural environment by keeping waterways clean.

### MARPOL Treaty

The USCG enforces the International Convention for the Prevention of Pollution from ships, commonly referred to as the MARPOL Treaty (MARine POLLution). This treaty prohibits the overboard dumping of all ship-generated plastics, chemicals, garbage and oil.

### Fuel/Spillage

### WARNING

**Fumes from rags can collect in bilge and be extremely hazardous. Do not store rags used to wipe-up fuel or solvent spills in the boat. Dispose of rags properly ashore.**

The spilling of fuel or oil into our waterways contaminates the environment and is dangerous to wildlife. Do not discharge or dispose of fuel or oil into the water; it is prohibited and you can be fined. These are two common, accidental types of discharge:

- Overfilling the fuel tanks
- Pumping contaminated bilge water

### Discharge/Disposal of Waste

Waste means all forms of garbage, plastics, recyclables, food, wood, detergents, sewage, and even fish parts in certain waters – in short, nearly everything. We recommend you bring back everything you take out with you for proper disposal ashore.

Use an approved pump-out facility at your marina. Many areas prohibit the discharge of sewerage overboard or even an operable overboard waste discharge.

### Excessive Noise

Noise means engine noise, radio noise or even voices. Many bodies of water have adopted noise limits. Don't use thru-transom exhaust unless you're well off shore. Music and loud conversation can carry a considerable distance on water, especially at night.

## Wake/Wash

Be alert for NO WAKE zones. You may be responsible for any damage or injury caused by your wake/wash. Prior to entering a no wake zone, come off plane to the slowest steerable speed.

## Exhaust Emissions

Increased exhaust (hydrocarbon) emissions pollute our water and air. Keep your engine tuned and boat hull clean for peak performance. Consult your Cobalt dealer and propulsion unit operator's manual for information.

## Paints

If your boat is kept in water where marine growth is a problem, the use of anti-fouling paint may reduce the growth rate. Be aware of environmental regulations that may govern your paint choice. Contact your local boating authorities for information.

## Cleaning Agents

Household cleaners should be used sparingly and not discharged into waterways. Do not mix cleaners and be sure to use plenty of ventilation in enclosed areas. DO NOT use products which contain phosphates, chlorine, solvents, non-biodegradable or petroleum based products. Citrus-based cleaners are excellent for marine cleaning purposes and are safe for you and the environment.

## Fishery Resources

There is a tremendous drain on our fishery resources. Over-fishing and pollution have strained the fish population. Do your part by keeping only what you will eat and practice catch-and-release.

## Foreign Species

If you trailer your boat from lake to lake, you may unknowingly introduce a foreign aquatic species from one lake to the next. Thoroughly clean the boat below the water line, remove all weeds and algae, and drain the bilge before launching the boat in a new body of water.

## Components, Maintenance and Repairs

Only your Authorized Cobalt Dealer should make any alterations, modifications or repairs that could affect safety, design integrity or warranty coverage.

Included with your owner's packet are your propulsion unit manuals. These manuals were prepared by the manufacturer and contain information concerning the operation and care of your engine and drive unit. Please read these manuals thoroughly and become acquainted with this information.

It is advisable to maintain a service log to record service checks, such as oil changes, so you can determine when it's time for servicing. A maintenance log is helpful when requesting warranty service using the extended warranty coverage. Be sure to collect receipts for work performed and make an entry in the **Service Log** in the back of this manual.

## Emergency Considerations

Be prepared to deal with emergencies before they happen. Try to formulate a plan for each type in advance so that decisions can be made quickly and without hesitation. Precious moments lost can mean the difference between losing and saving a life.

### Fire

You must be prepared and act quickly when dealing with a fire. It is not recommended to battle a fire for an extended period of time. Turn engines off and abandon the boat if the fire cannot be extinguished quickly. Swim at least 23 meters (25 yards) upwind from the boat and use the visual distress signals to get assistance.

### **WARNING**

**Gasoline will float on top of water and can burn. If the boat is abandoned, swim up wind, far enough to avoid fuel that may spread over the surface of the water to avoid serious injury.**

Onboard fires involving the fuel system usually result in either an explosion that completely destroys the boat, or the boat burning to the waterline and self-extinguishing. Deciding on abandoning the boat or staying to fight the fire is difficult and depends on many factors. Try to formulate a fire plan in advance to make that decision quickly and without hesitation.

The USCG and other law enforcement agency requirements for fire extinguishers are only the minimum needed. Your Cobalt is equipped with two fixed fire extinguishers, one in the generator compartment and one in the engine compartment. A portable fire extinguisher is located at the helm. Remember, install extra extinguishers where they might be needed. Inspect extinguishers on a regular basis.

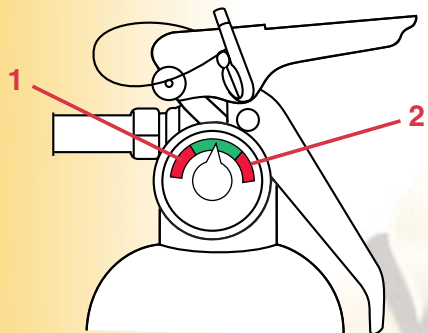

KC-0083C

1. Recharge
2. Overcharge

Be sure to:

- Use caution and do not smoke when refueling.
- Verify that fuel does not leak.
- Use only marine approved equipment on your boat.

### Flooding/Swamping

Improper loading, handling, water conditions, weather and anchoring are the most common causes of flooding. Insist on a safe, stable load. Do not operate the boat exceeding your ability to maneuver it. Use extreme caution in hazardous weather and rough water conditions. Anchor from the bow when using one anchor.

### Collisions/Leaks

If a collision occurs, immediately account for all passengers. Assess the hull for damage and activate the bilge pumps to reduce any water intake. Try to operate the boat to keep the damaged area above water. If necessary, call or signal for assistance.

If a leak is discovered, immediately determine the cause. A collision with an underwater object could cause the hull to develop a leak. A loose fitting or

hose clamp on a piece of equipment could cause a leak. Try to repair the leak if possible. If a leak is threatening the safety of you and your passengers, call or signal for assistance.

### Grounding

In the event you run aground, assess the situation before proceeding. Immediately stop any water from entering the boat. Inspect the propulsion units, steering and control systems, and the hull for damage. Maneuver the boat to safe water only if the hull and all operating systems are in satisfactory operating condition. Otherwise, call or signal for assistance.

### Storms

Take common sense precautions if you are forced to operate your boat in stormy conditions.

- Wear personal flotation devices (PFDs).
- Stow gear below deck and batten down equipment on deck.
- Reduce speed and head for a safe place that you can easily reach.
- If you lose power, keep the boat headed into the waves by using the anchor.

### Water Rescue (Man Overboard)

Immediately react to a person that has fallen overboard. Keep the victim constantly in your sight. Safely return to the victim as soon as possible. Throw the person a life preserver. Turn the engines off and help the person into the boat.

### Medical Emergency

Be prepared in the event of an emergency. Know how to use your first aid kit. Be aware of any special medical conditions of your passengers.

### Drowning

React to a drowning victim the same as described in Water Rescue. Handle the victim with care. They could be injured. If necessary, resuscitate the victim. Immediately signal for help and keep the victim warm.

### Operation Failure

If you experience a propulsion, steering or control failure, immediately turn off the engines. Release the anchor to prevent drifting. Try to determine the failure and repair, if possible. Otherwise, call or signal for assistance.

# Responsibilities and Safety

## Distress Signals

Federal law also requires boats 4.8 m (16 ft) and longer to carry day and night visual distress signals when operating on coastal waters, the Great Lakes, territorial seas or those waters directly connected to them, up to a point where the body of water is less than two miles wide. Carry several types of signaling devices to handle a variety of conditions. Have enough signals on board to last three days.



**NOTICE: Some pyrotechnics are restricted from use on certain bodies of water, so check with local authorities.**

## Radio Communication

Radio communication is the most important avenue of receiving and sending information. Use a VHF/FM radio for short-range communication, and a single-sideband radio (SSB) for long-range.

For all U. S. waters, the National Weather Service operates the NOAA Weather Radio (NWR). This service provides continuous weather information on the following VHF/FM frequencies:

- 162.400 MHz
- 162.425 MHz
- 162.450 MHz
- 162.475 MHz
- 162.500 MHz
- 162.525 MHz
- 162.550 MHz

## Coast Guard Marine Information Stations

- 2670.0 kHz
- 4428.7 kHz
- 6506.4 kHz
- 8765.4 kHz
- 13113.2 kHz

It is good practice to periodically monitor the weather.

## Life Saving Equipment

The following equipment may or may not be required by federal/local regulations.

## Personal Flotation Devices

Federal law requires at least one Type I, II, III, or V Personal Flotation Device (PFD) for each person on board or being towed, and at least one Type IV throwable PFD in the boat.

There are four types of PFDs to wear and one type used for throwing in emergency situations.

Type I Life Preserver: Most buoyant PFDs are effective on all waters, especially open, rough water.

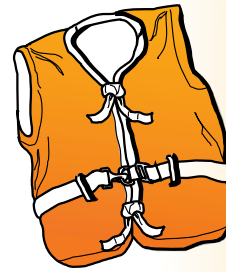

TYPE I  
LIFE PRESERVERS

KC-0041C

Type II Buoyant Vest: Good for calm water near shore on most inland waters where quick rescue is likely.

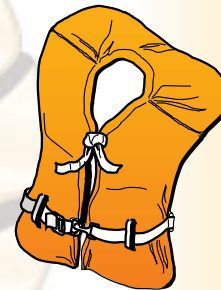

TYPE II  
BUOYANT VESTS

KC-0051C

Type III Flotation Aid: Good for most inland water applications where quick rescue is likely. Comes in various styles and some are designed for watersport activities.



TYPE III  
FLOTATION AIDS

KC-0042C

**Type IV Throwable Device:** Intended for heavy traffic inland waters where help is available. Designed to be thrown to a person in the water and should never be worn.



TYPE IV  
THROWABLE DEVICES  
KC-0071C

**Type V Hybrid PFD:** Inflatable design for special use activities and may be used instead of a Type I, II, or III PFD if used in accordance with the approval conditions on the label and if worn when the boat is underway. Some Type V PFDs provide increased protection against hypothermia.

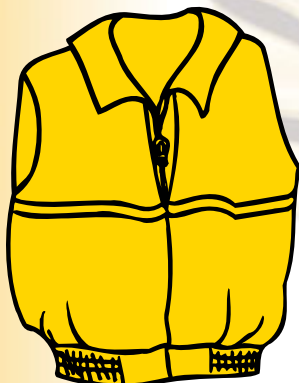

TYPE V HYBRID PFD  
MUST BE WORN  
WHEN UNDERWAY

KC-0043C



**NOTICE:**

- A Type V PFD must be worn to be counted toward the minimum carriage requirements.
- Special PFDs are available for skiing and other watersports. These PFDs are constructed with materials suitable for high impact falls.

PFDs are intended to help save lives. The operator should set an example by wearing one. Wear a PFD whenever boating. It is especially important that children and non-swimmers wear a

PFD at all times. Make certain all passengers know how to put on and properly adjust their PFDs. Also, selecting the proper type PFD for your kind of outing helps ensure your time on the water can be the safest possible.

At the beginning of each season, check PFDs for damage and test for proper flotation. Refer to the PFD manufacturer's information.

**Audible/Visual Distress Signals**







A distress call is transmitted on VHF/FM radio channel 16 (156.800 MHz) or 2182 kHz (SSB). Know your audible signals:

- For emergency, the call sign is "Mayday."
- An urgent situation, the call sign is "Pan-Pan."
- For navigational safety and weather warnings, the call sign is "Security."

Repeat the call sign three times.

Immediately react to a distress call. Assist, if possible, using an emergency frequency. Otherwise continue to monitor the situation until help has arrived.

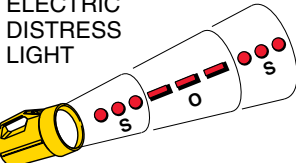
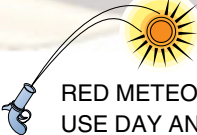
**VISUAL DISTRESS SIGNALS**

 USE DAY ONLY	RED DISTRESS FLARE (HAND)  USE DAY AND NIGHT
 ARMS SIGNALS (USE BRIGHT CLOTH) USE DAY ONLY	USE DAY ONLY  SIGNAL (HAND)
ELECTRIC DISTRESS LIGHT  USE NIGHT ONLY	 RED METEOR FLARE USE DAY AND NIGHT
 DYE MARKER USE DAY ONLY	

COB024C

# Responsibilities and Safety

If you are required to carry distress signals, you must have three USCG approved pyrotechnic devices. Be sure they are in serviceable condition, not exceeding the expiration date and stored in a cool, dry location in a waterproof container.

 **WARNING**

**Pyrotechnic signaling devices can cause injury and property damage if improperly handled. Follow the manufacturer's directions.**

## Sea Anchors

You should have a separate sea anchor onboard to slow drifting. In heavy seas, a sea anchor is set from the bow to control the boat's behavior. The sea anchor holds the bow to the sea and a slow drift.

## Radar Reflectors

Radar reflectors allow you to be seen by other vessels' radar within your area. Mount the reflector as high as possible on the radar arch.

## Life Raft

If operating offshore, you should consider carrying an inflatable life raft. A USCG approved life raft meets a number of stringent specifications. The life raft must be large enough to hold all the boat's occupants and have its own equipment pack including a paddle.

## SAFETY

The popularity of boating and other water sports has undergone an explosion in growth the past few years. Because of this, safety is an important issue for everyone who shares in the use of our waterways.

## Signal Words/Definitions

Throughout this manual specific precautions and symbols identify safety related information.

The Safety Alert Symbol means ATTENTION! BECOME ALERT! YOUR SAFETY IS INVOLVED!

 **DANGER** 

**Indicates the presence of a hazard which WILL cause SEVERE injury, death or substantial property damage.**

 **WARNING**

**Indicates the presence of a hazard which CAN cause SEVERE injury, death or substantial property damage.**

**CAUTION**

**Indicates the presence of a hazard which WILL or CAN cause MINOR or MODERATE personal injury or property damage.**

 **NOTICE:**  
**Indicates installation, operation or maintenance information which is important but not hazard-related.**

The precautions listed in this manual and on your Cobalt boat are not all-inclusive. If a procedure, method, tool, or part is not specifically recommended, you must satisfy yourself that it is safe for you and others, and that the boat will not be damaged or made unsafe as a result of your decision. **REMEMBER – USE COMMON SENSE WHEN OPERATING YOUR BOAT!**

## General Safety

### WARNING

- **Read and understand this manual and the propulsion unit manual, and be sure that you understand all controls and operating instructions before attempting to operate the boat. Improper operation can be extremely hazardous.**
- **Be in control of your boat. Do not operate your boat under the influence of alcohol or other drugs.**

Before each outing you should check all safety equipment, such as fire extinguishers, PFDs, flares, distress flags, flashlights, engine stop switch, etc. They should be operable, in good condition, readily visible, and easily accessed.

Check local weather reports before casting off; do not leave the dock area when strong winds and electrical storms are in the area or predicted to be in the area.

Tell someone your travel plans and leave them a float plan. A float plan makes the job of search and rescue much easier for authorities. A float plan template can be found in the back of this manual.

## Seating

### WARNING

**Do not allow passengers to sit in the two stern sun lounges when the boat is underway.**

Keep your passengers seated in seats. The boat's bow, gunwale, transom platform and seat backs are not intended for use as seats while underway.

## Handholds

### WARNING

**Passengers should use handholds whenever the boat is underway.**

Handholds are provided for your passengers' safety. Be sure your passengers use the handholds whenever the boat is underway. Failure to use handholds could result in a man overboard situation or personal injury.

## Capacity

Know the weight capacity of your boat. Do not overload your boat. Overloading of passengers, personal equipment and supplies could result in an accident, especially in rough waters.

## Loading

Be sure that passengers, personal equipment and supplies are in their proper location before operating the boat. It does not necessarily mean you can carry a passenger for every seat. Keep personal equipment and supplies to an "as needed" basis. Maintain a balanced load (front to back and side to side) at all times.

## Operating Conditions

Every waterway poses hazards that you should avoid, such as shallow water, tree stumps and sand bars. Ask local boaters for information and consult a marine chart when boating on unfamiliar waters. As the operator of the boat, you should try to avoid all hazards, known and unknown. The following information does not contain all possible water hazards.

Operating in shallow water presents a number of hazards. Mud, sand, weeds and debris can foul a propulsion unit propeller or its cooling water. If a propulsion unit strikes an underwater object, check the propulsion unit and boat for damage. If a propulsion unit vibrates after striking an object, it may indicate a damaged propeller.

Sand bars in narrow inlets are constantly shifting, making it difficult to mark them with buoys. Tides in coastal areas affect water levels producing sand bars. Sometimes sand bars are indicated by waves as they form into breakers when passing over the sand bar. Refer to **Grounding**, in this section, if you run aground on a sand bar.

The water level around a dam spillway is a hazardous area. It is subject to rapid changes caused by currents and turbulence. Keep clear of the spillway areas below dams.







## Weather/Seas

Getting caught in severe weather is hazardous. It is recommended to check the weather, sea and wind conditions not only before, but, periodically while you are boating. Refer to **Radio Communications**, in this section, for weather channel information.

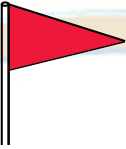
A change in wave height, wind direction and speed indicates deteriorating weather. Take common sense precautions if you are forced to operate your boat in stormy conditions:

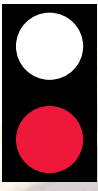
- Wear PFDs.
- Stow gear below deck and batten down equipment on deck.
- Reduce speed and head for a safe place that you can easily reach.
- If you lose power, keep the boat headed into the waves by using the anchor.

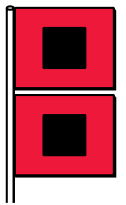
Learn the storm signals.

DAYTIME WARNING	DESCRIPTION	NIGHTTIME WARNING
	<b>Small Craft Advisory</b> - Winds greater than 18 knots, sustained for two hours or more or hazardous wave conditions. Following a storm, hazardous wave conditions can persist long after the high winds have subsided.	
	<b>Gale Warning</b> - Sustained winds (2 or more hours), of 34-47 knots.	
	<b>Storm Warning</b> - Sustained winds of 48 knots or greater.	
	<b>Hurricane Warning</b> - Forecast winds of 64 knots and above. Displayed only in connection with a hurricane.	

COB025C

It is best to avoid operating your boat in foggy weather. When fog sets in, use your GPS and radar unit, if equipped, to take bearings and log courses and speeds. You are required to emit a five-second blast from your horn or whistle once every minute. Additionally, have passengers wear PFDs and observe for oncoming vessels.

## Skill/Experience

 **WARNING**

**Wear your PFD and remain seated when operating the boat.**

Practice your boat operating skills often in calm water. Avoid windy conditions and rough water. Be sure to maintain good visibility at all times. Do not practice close to any obstructions such as piers, bridges, swim areas or moored boats.

Proceed slowly and give yourself plenty of time to react. Remember, your boat is not an automobile. It requires additional time to maneuver and stop.

## Visibility

 **WARNING**

**Clear visibility must be maintained at all times. If necessary, arrange passengers and equipment. Designate a passenger to assist when visibility is limited due to operating conditions.**

Visibility is not only sight, but also hearing. It is very important the operator maintains good visibility at all times. Arrange passengers and equipment to ensure you have unobstructed vision at all times. Check for other boats or any obstacles before turning the boat.

### Drugs/Alcohol

#### **! WARNING**

**Federal and state law prohibit operating a boat under the influence of alcohol and other drugs. These regulations are actively enforced. Impaired operation may result in severe personal injury or death.**

Boating, alcohol and the use of other drugs just don't mix. Mixing boating, alcohol and other drugs results in many marine accidents and deaths. These substances reduce your reaction time and affect your better judgement. Combined with the sun, wind, waves, and noise of other watercraft, the effects of drugs are increased and will significantly reduce your reaction time. As the owner/operator, you are responsible for the alcohol/drug use and onboard behavior of your passengers.



**NOTICE:** If the operator's blood alcohol content is 0.10% (0.08% in some states) or above, violators are subject to a civil penalty up to \$1,000.00 or criminal penalty up to \$5,000.00, one year imprisonment or both. Operating a boat under the influence can also result in a loss of automobile driving privileges.

### Passengers

Whenever you are going for an outing, make sure that at least one passenger is familiar with the operation and safety aspects of the boat in case of emergency. Show all passengers the location of emergency equipment and explain how to use it. Don't allow passengers to drag their feet or hands in the water, or sit on the bow, deck, gunwale or transom platform while the engines are running.

### Ventilation

#### **! WARNING**

**Test the carbon monoxide detectors operation before each trip, at least once a week and after the boat has been in storage. Do not tamper with the operation of the carbon monoxide detectors. They are installed for your safety.**

Your Cobalt 360 boat is equipped with two carbon monoxide (CO) detectors. One detector is located in the cabin and the second is located in the midberth.

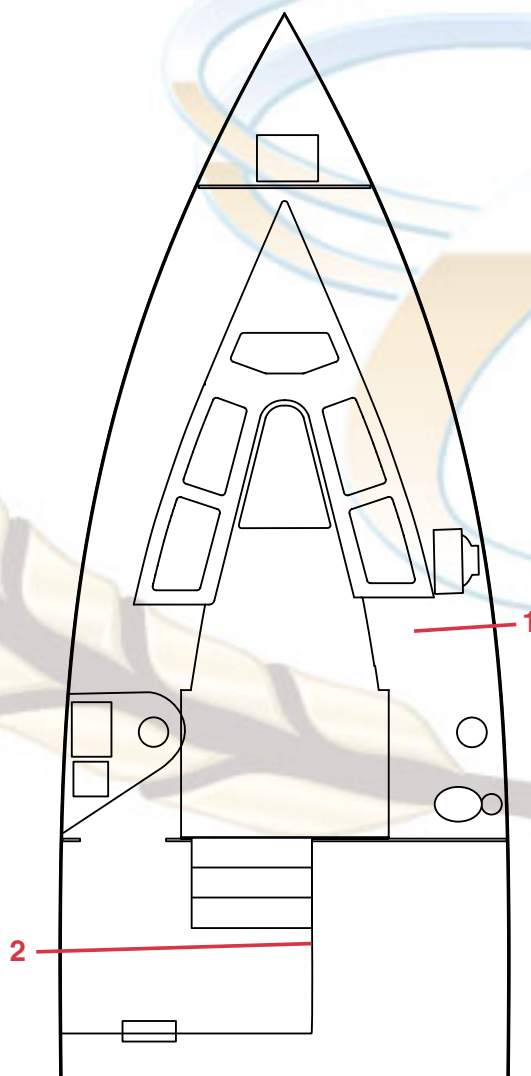

COB027

1. Cabin CO Detector
2. Midberth CO Detector

# Responsibilities and Safety

## CAUTION

A carbon monoxide (CO) detector will only detect the presence of carbon monoxide gas at its sensor. Carbon monoxide may be present in other areas.



**NOTICE:** A carbon monoxide detector will not detect other vapors such as gasoline.



Carbon Monoxide (CO) is a colorless and odorless gas produced by all engines and fuel burning appliances such as heaters, stoves and generators. Even with the best boat design and construction, plus the utmost care in inspection, operation, and maintenance, hazardous levels of CO may still be present in accommodation spaces under certain conditions. Dizziness, ears ringing, headaches, nausea, unconsciousness and cherry red skin color are symptoms of carbon monoxide poison.

KC-5032

To reduce CO accumulation:

- Ventilate the boat interior by opening the deck hatches, windows and cabin door to provide adequate ventilation.
- Do not operate the engines or generator with the canvas installed.
- Only operate fuel burning appliances in well-ventilated areas.
- Avoid idling or using the generator while at idle for extended periods.
- Regularly inspect the engine and generator exhaust system for proper operation.
- Do not use any fuel burning appliances with a transom exhaust port when swimming from the stern swim platform.

Have a suspected CO victim deeply breathe fresh air and immediately seek medical attention.

Blockage of boat exhausts by obstruction.

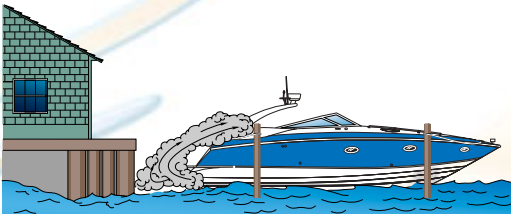

Operating with high bow angle.

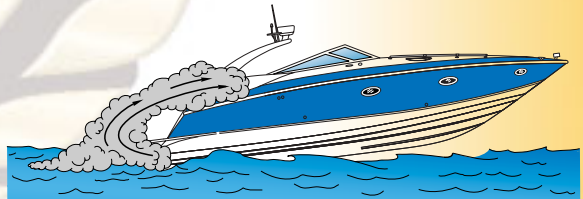

Exhausts traveling along obstruction.

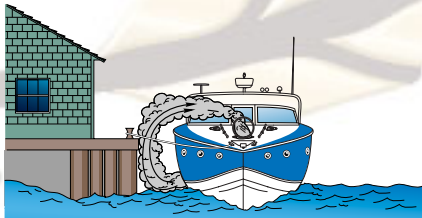

Exhausts from other vessels in confined areas.

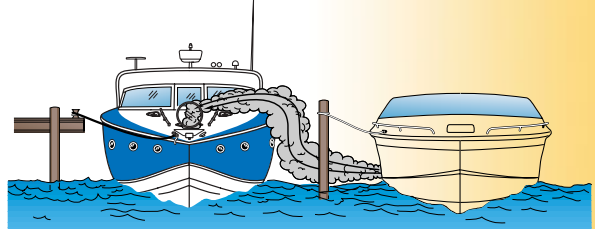

Operating at slow speed or while dead in the water.

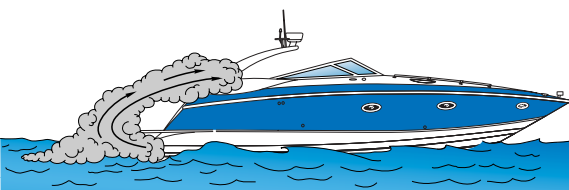

Operating with canvas tops and side curtains in place without ventilation.

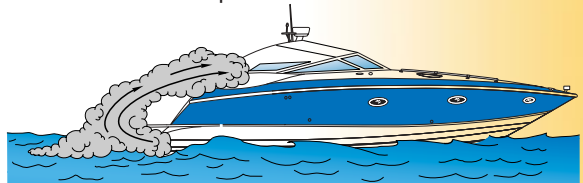

COB093

## Qualified Boat Operators

This manual is not intended to provide complete training on all aspects of boat operation. We strongly recommend that all operators of this boat seek additional training on boat handling and safety. Have all operators become familiar with the handling characteristics, and proper steering and control system usage before attempting high-speed operation.

Some states require youths 16 years of age and younger to complete a boating safety course before operating any watercraft. Many others require operators under the age of 18 to be licensed in small boat operation.

Minors must be supervised by an adult whenever operating a boat. Many states have laws regarding the minimum age and licensing requirements of minors. Be sure to contact the state boating authorities for information.

## Safety While Boating

Your boat is affixed with various safety labels at the time of manufacture. These labels appear at specific locations on the craft where safety is of particular concern. Refer to **Warning Labels**, in **Section 1**.

Safety labels must remain legible. If you suspect a label is missing or becomes damaged, please contact your Cobalt dealer for immediate replacement.

## Federal, State and Local Regulations

The USCG is the authority of the waterways; they are there to help the boating public. State boating regulations are enforced by local authorities. You are subject to marine traffic laws and “Rules of the Road” for both federal and state waterways; you must stop if signaled to do so by enforcement officers, and permit to be boarded as asked.

## Discharge of Oil

The discharge of fuel, oil and other chemicals into the water is prohibited. Be sure to clean up all fuel and oil spillage in the bilge using rags and sponges. Properly store and dispose of them when you get to shore. Do not allow any fuel or oil spillage to be pumped out into the water. If fuel or oil leakage continues to be a problem, immediately have the problem repaired.

When refueling, do not “top-off” the fuel tanks. Allow for expansion which will reduce fuel spillage from the fuel tank vents.

## Solid Waste Disposal



**NOTICE: It is illegal to dispose of any plastic trash into waters of the U.S.**

The disposal of solid waste and plastics into the water is prohibited. Bag all refuse and properly dispose of it when you get ashore.

## Marine Sanitation



**NOTICE: Direct disposal of sanitation waste into some waters could result in being fined. Be sure to check local regulations.**

## CAUTION

**To avoid damaging the waste disposal system and the environment, do not place facial tissues, paper towels or sanitary napkins in the head.**

Have your Cobalt dealer properly service the waste disposal system when needed.

## Excessive Noise

Noise limits are regulated in many areas. Be sure to follow regulations and be courteous.

## Wake/Wash



## WARNING

**You are responsible for injury and damage caused by your wake.**

Observe “No Wake” markers. Use caution when operating around smaller crafts, in channels and marinas, and in congested areas.

## Reporting Accidents

The USCG requires the owner or operator of a boat involved in an accident, to report the incident to the proper marine law enforcement agency for the state in which the accident occurred.

# Responsibilities and Safety

Immediate notification to the nearest State boating authority is required if a person dies or disappears as a result of a recreational boating accident. If a person dies or sustains injuries requiring more than first aid, a formal report must be filed within 48 hours of the accident. A formal report must be filed within 10 days for accidents exceeding \$500 in property damage or complete loss of boat.

## Rendering Assistance

If you see a distress signal or suspect a boat is in trouble, you must assume it is a real emergency and render assistance immediately. By law, the operator in charge of the craft is obligated to provide assistance to any individual in danger if such assistance can be provided safely. Failure to render assistance can result in a fine and/or imprisonment.

The 1971 Boating Safety Act grants protection to a "Good Samaritan" boater providing good faith assistance, and absolves a boater from any civil liability arising from such assistance.

## Watersports Safety

Larger boats produce a wake too big for skiers. Only boats equipped with a ski-tow eye should be used to pull water skiers. It is unlikely that anyone would ski behind your Cobalt 360 Performance Cruiser, but you should be familiar with water sport safety and hand signals.

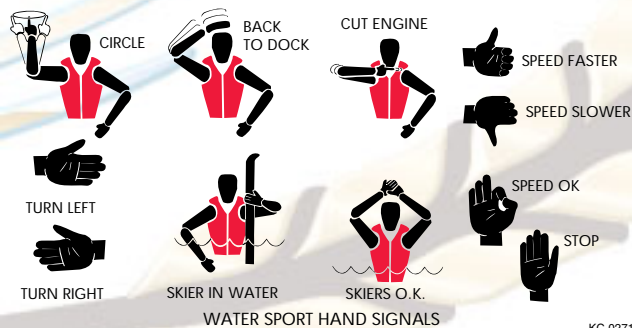

**NOTICE:** It is unlawful to participate in water sports while under the influence of alcohol or other drugs.

When participating in water sports, be safe and courteous and follow these guidelines:

- Be considerate to fishermen and others you share the water with.
- Do not perform water sports in congested areas.
- Stay away from navigation markers.
- Stay away from other boats and water sports participants.
- Return immediately to a fallen water sport participant.
- Regularly inspect water sport equipment to ensure it is safe.
- Do not use any fuel burning appliances with a transom exhaust port when swimming from the stern swim platform.

## WARNING

- **Water sport participants must wear a USCG approved floatation device. A Type III water ski vest is an approved and practical PFD.**
- **Keep at least 30 m (100 ft ) away from all other objects.**
- **When water sporting, have an experienced driver and aft facing observer in the boat.**
- **Do not water sport in shallow water or at night.**
- **Do not jump from a moving boat.**
- **Keep a downed water sporter in sight.**
- **Turn the engines off before you get close to someone in the water.**

## NAVIGATION

### Rules of the Road/Sound Signals

The General Prudential Rule regarding right-of-way is that if a collision appears unavoidable, neither boat has right-of-way. As prescribed in the Rules of the Road, both boats must act to avoid collision.

The information in this section outlines only the most basic of the nautical rules of the road. For more information, contact your local USCG Auxiliary.



## WARNING

**The nautical rules of the road must be followed to prevent collisions between vessels. Like traffic laws for automobiles, the operator is legally required to follow the rules.**



**NOTICE: In general, boats with less maneuverability have right-of-way over more agile craft. You must stay clear of the vessel with right-of-way and pass to his stern.**

### Whistle/Horn Signals

Signaling other boats with a whistle or horn is similar to using turn signals on an automobile. It is not necessary to sound a signal every time a boat is nearby. In general, boat operators should signal their intention to avoid potentially confusing or hazardous situations.

It is customary for the privileged boat to signal first, and the give-way boat to return the same signal to acknowledge she understands and will comply. Use the danger signal (five or more short and rapid blasts) if intent is not clear.

Use the following signal blast early enough to be noticed and understood by other boaters:

- One long blast: Warning signal (coming out of slip or passing astern)
- One short blast: Pass on my port side
- Two short blasts: Pass on my starboard side
- Three short blasts: Engines in reverse
- Five or more short and rapid blasts: Danger signal!

## Encountering Vessels

### Privileged Boats

Privileged boats have right-of-way and can hold course and speed. Sailboats and boats paddled or rowed have the right-of-way over motor boats. Sailboats under power are considered motorboats. Small pleasure craft must yield to large commercial boats in narrow channels.

### Burdened Boats

The burdened boat is the boat that must make whatever adjustment to course and speed necessary to keep out of the way of the privileged boat.

### Crossing Situation

In crossing situations, the boat to the right from the 12 o'clock to the 4 o'clock position has the right-of-way. It must hold course and speed. The burdened boat keeps clear and passes behind the privileged boat. Boats going up and down a river have the privilege over boats crossing the river.

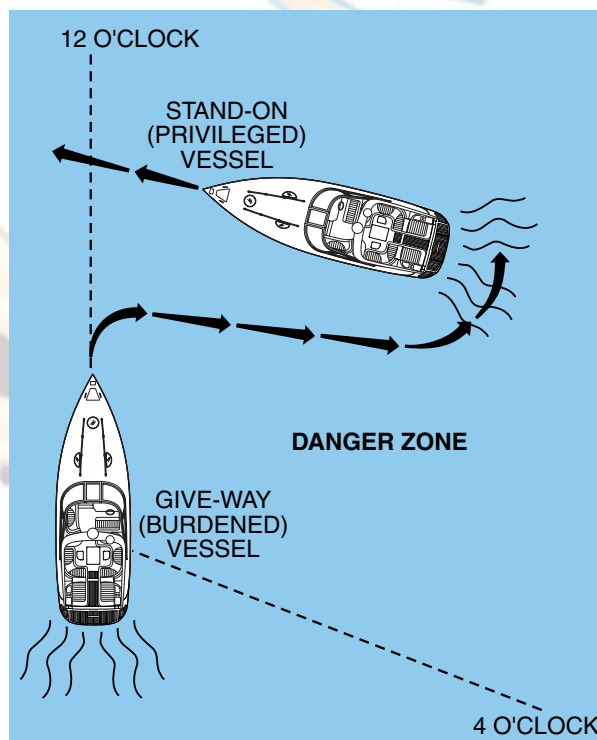

COB017C

# Responsibilities and Safety

## Meeting Head-On

Neither boat has the right-of-way in this situation. Both boats should decrease speed, should turn to the right, and pass port-to-port. However, if both boats are on the left side of the channel, each vessel should sound two short blasts and pass starboard-to-starboard.

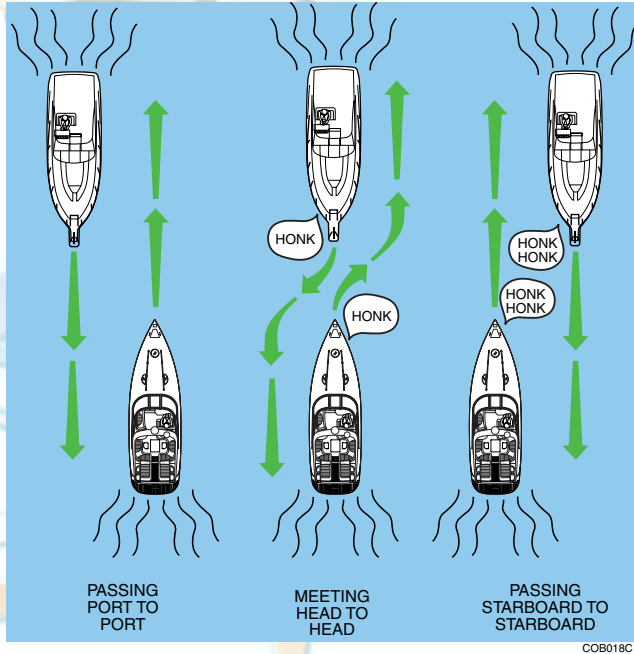

## Overtaking

The boat that is overtaking one ahead of it is the give-way boat and must make any adjustments necessary to keep out of the way of the stand-on boat. The stand-on boat should hold its course and speed.

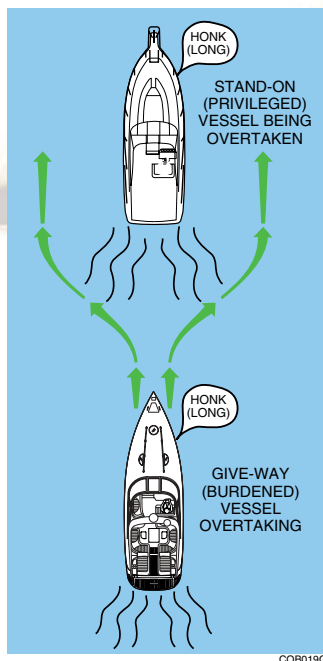

## Special Situations

Boats operating between sunset and sunrise (hours vary by state) must use navigational lights, nighttime operation, especially during bad weather or fog can be dangerous. All "Rules of the Road" apply at night; it is best to slow down and stay clear of all boats, regardless of who has right-of-way.

Protect your night vision by avoiding bright lights and have a passenger, if possible, help keep watch for other boats, water hazards, and aids to navigation.

The size, speed, and direction of the other vessels are determined at night from the running lights. A green light indicates the starboard side of the boat, and a red light indicates the port side. Generally, if you see a green light, you have the right-of-way; if you see a red light, give-way to that vessel.

## Navigational Aids

Learn to recognize the different buoys and day markers; they are the signposts of the waterways. There are two primary marking systems in use in the U.S.; the Uniform State Waterway Marking System (USWMS) used on inland waters and maintained by each state, and the Federal Waterway Marking System (FWMS) used on coastal waters and rivers and maintained by the USCG. In addition, the FWMS has two modified systems; the Western River Buoyage, and the Intercoastal Waterway Buoyage. Be sure to check with local authorities on the buoyage system in use.

The only buoys you are permitted to moor to are mooring buoys. Mooring to a navigation buoy or other navigational aid or regulatory marker is illegal.



MOORING BUOY

MAY SHOW WHITE REFLECTOR OR LIGHT

KC-0412C

The type of hazard/warning buoys and markers depends on the area of jurisdiction. Check with local boating authorities.

The USWMS Cardinal System is used when there is no well defined channel or where an obstruction may be approached from more than one direction. With the cardinal system:

- Pass north or east of BLACK-TOPPED WHITE buoy.

- Pass south or west of RED-TOPPED WHITE buoy.
- RED and WHITE VERTICALLY STRIPED buoy indicates boat should pass outside of the buoy (away from shore).

**Uniform State Regulatory Markers**

USWMS regulatory markers are white with international orange geometric shapes; you must obey regulatory markers.

UNIFORM STATE WATERWAY MARKING SYSTEM (USWMS)

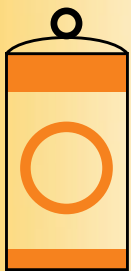

CONTROLLED AREA



DANGER



BOATS KEEP OUT



INFORMATION



DO NOT PASS BETWEEN SHORE AND BUOY



SPECIAL PURPOSE



NAVIGATE TO STARBOARD FACING UPSTREAM



NAVIGATE TO PORT FACING UPSTREAM

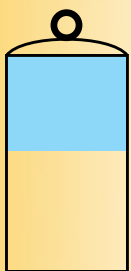

NAVIGATE TO SOUTH OR WEST



NAVIGATE TO NORTH OR EAST

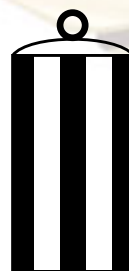

MID-CHANNEL

COB020C

# Responsibilities and Safety

## FWMS

The FWMS Lateral System is for use on navigable waters except Western Rivers and Intercoastal Waterways.

The markings on these buoys are oriented from the perspective of being entered from seaward (the boater is going toward the port). This means that red buoys are passed on the starboard (right) side of the vessel when proceeding from open water into port, and green buoys to the port (left) side.

The right side (starboard) of the channel is marked with RED, even numbered buoys. The left (port) side of the channel is marked with GREEN, odd numbered buoys.







The middle of the channel is marked with RED and WHITE vertically striped buoys; pass close to these buoys.

Obstructions, channel junctions, etc. are marked with RED and GREEN horizontally striped buoys.

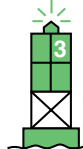
A RED band at the top means the preferred channel is to the left of the buoy; a GREEN top band means the preferred channel is to the right of the buoy.

Day markers are colored and numbered the same as buoys. RED, triangular day markers with even numbers mark the starboard side of the channel. GREEN, square day markers with odd numbers mark the port side of the channel.

Lights, bells and horns are used on buoys for night or poor visibility conditions. Buoys with unique light flashing characteristics are identified on nautical charts with the specific flashing pattern.

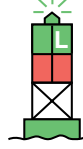
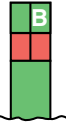
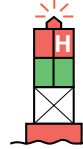
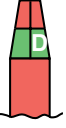
Federal Waterways Marking System (FWMS)			
Lateral Aids Marking the Sides of Channels as seen When Entering From Seaward	Port Side Odd Numbers	 Lighted Buoy	 Can Buoy
	Starboard Side Even Numbers	 Lighted Buoy	 Nun Buoy
Safe Water Aids Marking Mid-Channels and Fairways (No Numbers—May be Lettered)	 Lighted	 Spherical Buoy	 Daymark
Preferred Channel Aids (No Numbers—May be Lettered)	Preferred Channel to Starboard	 Lighted Buoy	 Can Buoy
	Preferred Channel to Port	 Lighted Buoy	 Nun Buoy

COB021C

### Light Structures

Maneuvering a boat at night can be dangerous and confusing. To aid boaters with navigation and warn of hazards, the USCG and the state and local authorities maintain a variety of light structures. Some light structures may be equipped with radio beacons, radar reflectors, and/or signals.

### Minor Lights

Minor lights are colored according to the buoyage marking system in use. They are similar to lighted buoys, except they are usually higher and on more stable platforms to increase visibility. Most minor lights are part of a series to mark a channel, river or harbor.

### Range Lights

Range lights are usually visible in one direction and help a boat operator navigate in a generally safe direction. Steering a course to keep range lights arranged in a line (one on top of the other) will help guide a boat through a channel.

### Lighthouses

Lighthouses can be found at harbor entrances, prominent headlands, isolated danger areas, and along the coast. These striped or patterned structures have unique flashing characteristics to help identify them.



KC-0443C

RANGE LIGHTS

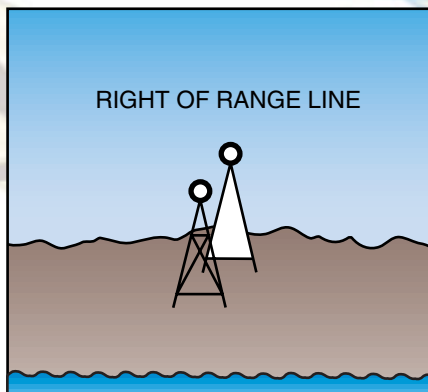
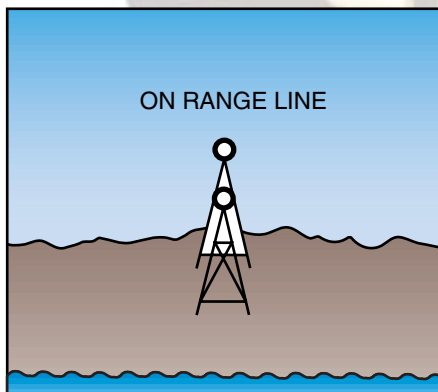
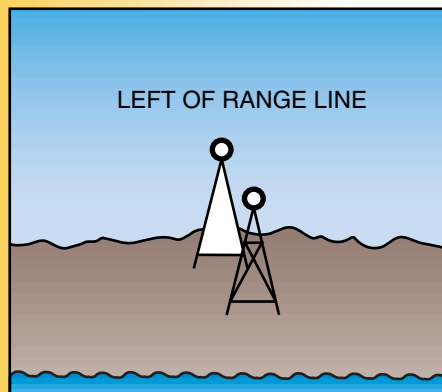
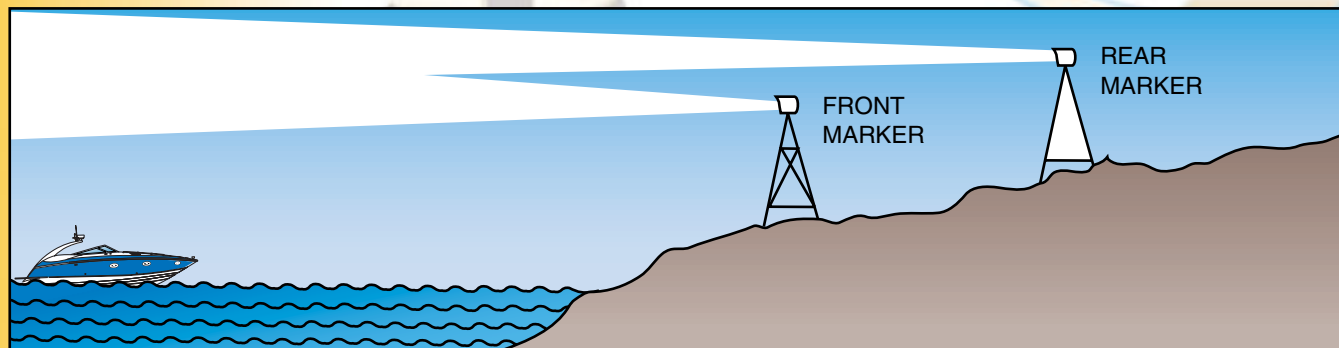

COB022C

# Responsibilities and Safety

## Warning Markers

DIVERS FLAG



USED BY RECREATIONAL DIVERS - INDICATES DIVER'S POSITION

ALPHA FLAG



WORLDWIDE VESSELS ENGAGED IN DIVING OPERATIONS - DOES NOT INDICATE DIVER'S POSITION

DISTRESS FLAG



INDICATES FELLOW BOATER IS IN NEED OF ASSISTANCE



KC-0260C

Navigation markers serve as a means of identifying navigable routes, and indicate water hazards. Boaters should become familiar with navigation markers and stay within marked boundaries and clear of hazards.

COB023C

It is a good idea to ask local authorities if there are hazardous areas and how they are marked. Boaters must also recognize the flag designs which indicate that skin divers are present and keep well clear of the area.

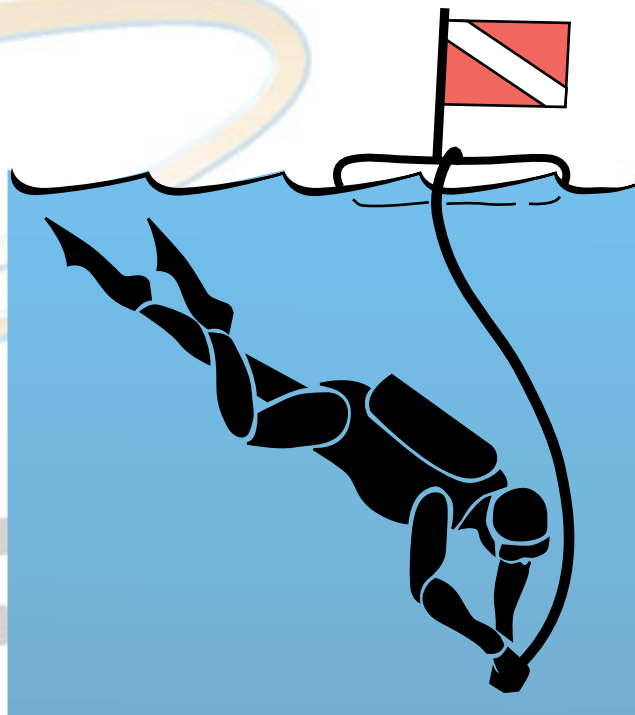

KC-0250C

Watch for swimmers. Swimming areas may not be marked. Steer clear from the area and remain alert.



This section is not intended to provide complete training on all aspects of boat operation. We strongly recommend that all operators of this Cobalt Performance Cruiser seek additional training on boat handling and safety. Have all operators become familiar with the handling characteristics and proper steering and control system usage before attempting high-speed operation.

## PRECAUTIONS

Become familiar with the location and operation of all equipment. Have emergency plans in place. Be sure to perform a safety check before operating your boat.

### CO Poisoning

#### **DANGER**

Carbon monoxide gas (CO) is colorless, odorless and extremely dangerous. All engines and fuel burning appliances produce CO as exhaust. Direct and prolonged exposure to CO will cause **BRAIN DAMAGE** or **DEATH**. Signs of exposure to CO include nausea, dizziness and drowsiness.

#### **WARNING**

Test the carbon monoxide detector operation before each trip, at least once a week and after the boat has been in storage. Do not tamper with the operation of the carbon monoxide detectors. They are installed for your safety.

#### **CAUTION**

A carbon monoxide (CO) detector will only detect the presence of carbon monoxide gas at its sensor. Carbon monoxide may be present in other areas.



**NOTICE: A carbon monoxide detector will not detect other vapors such as gasoline.**



KC-5032

To reduce CO accumulation

- Ventilate the boat interior by opening the deck hatches and windows to provide adequate ventilation.
- Do not operate the engines or generator with the canvas installed.
- Only operate fuel burning appliances in well-ventilated areas.
- Avoid idling for extended periods.
- Regularly inspect the exhaust system for proper operation.
- Do not use any fuel burning appliances with a transom exhaust port when swimming from the stern swim platform.

For additional information, refer to the carbon monoxide detector operator's manual supplied with your boat.

### Fire/Explosion

Most fires are the result of gasoline and oil accumulating in the bilge from careless fueling practices. Use the fire extinguisher at the base of the flames using a sweeping motion. Prudent and accurate use of the available chemicals should contain all but the worst fires. Verify that the fire has been extinguished. If so, check damage and get assistance immediately. If not, get out and swim at least 23 meters (25 yards) upwind from the boat and use the visual distress signals to get assistance. Refer to **Safety**, in **Section 2**, for additional information.

## Boating Under the Influence

### WARNING

Federal and state law prohibit operating a boat under the influence of alcohol and other drugs. These regulations are actively enforced. Impaired operation may result in severe personal injury or death.



**NOTICE:** If the operator's blood alcohol content is 0.10% (0.08% in some states) or above, violators are subject to a civil penalty up to \$1,000.00 or criminal penalty up to \$5,000.00, one year imprisonment or both. Operating a boat under the influence can also result in a loss of automotive driving privileges.

Do not operate your boat under the influence of alcohol or other drugs. You are responsible for the safety of your passengers.

## FIRST TIME OPERATION

### WARNING

Read and understand this manual and the propulsion unit operator's manual, and be sure that you understand all controls and operating instructions before attempting to operate the boat. Improper operation can be extremely hazardous.

Your safety, the safety of your passengers, and other boaters are among your responsibilities as operator of this boat. Your boat must be in compliance with USCG safety equipment regulations. You should know how to react correctly to adverse weather conditions, have good navigation skills, and follow the "rules of the road" as defined by the USCG and state, county and local regulations.

We cannot stress enough the importance of reading your propulsion unit operator's manuals and following the manufacturer's instructions for breaking in your engines.

Before each outing you should check all safety equipment, such as fire extinguishers, PFDs, flares, distress flags, flashlights and engine stop switch. They should be operable, in good condition, readily visible, and easily accessed.

## Fueling

### DANGER

Gasoline is extremely flammable and highly explosive under certain conditions. Stop the engines and generator, and do not smoke or allow open flames or sparks within 15 m (50 ft) of the fueling area.

### WARNING

All precautions must be taken every time you fuel your boat, whether it's gasoline or diesel fuel. Diesel fuel is non-explosive, but it will burn.

### CAUTION

To prevent unwarranted engine damage, refer to your propulsion unit operator's manual for recommended fuel type and octane rating.

Take care not to spill gasoline. If gasoline is accidentally spilled, wipe up all traces of it with dry rags and immediately dispose of the rags properly ashore. Spilled fuel may yellow the gelcoat finish and damage gunwale trim.

### When fueling:

1. Know your fuel tank capacity. Be sure to have enough fuel to reach your destination. If departing for an extended cruise, know the availability of fuel along your route. Practice the One Third Rule: one third to reach the destination, one third to return and one third in reserve.
2. Avoid fueling at night, except under well-lighted conditions.
3. Moor your boat securely to the dock. Know the location of the fire extinguisher in case of emergency.

4. Keep accurate records of your fuel consumption. A fuel log tracking fuel use over time will help determine average consumption.
5. Close all doors, hatches, windows and other compartments.
6. Extinguish cigarettes, pipes, and all other flame producing items.
7. Make sure all power is off, and do not operate any electrical switches.
8. Remove the fuel fill cap using the fuel cap key supplied with your boat.

TYPICAL DECK PLATE KEY

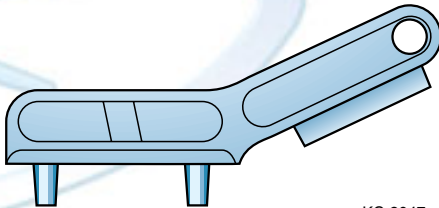

KC-2047

9. Insert the hose nozzle and make sure nozzle is in contact with or grounded against fill opening. This will reduce the risk of static spark.

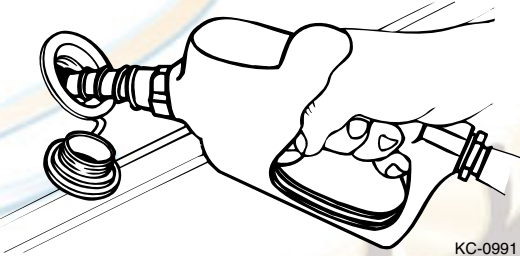

KC-0991

10. Add fuel in accordance with the propulsion unit operator's manual. Do not overfill, and allow enough room for fuel expansion.



#### NOTICE:

- Each time you refuel, inspect all fuel lines, hoses and connections for leaks and deterioration.
- The Federal Water Pollution Control Act prohibits the discharge of oil or oily waste into the water. Violators can be fined \$5,000.00. We urge you to protect our fragile environment by avoiding any type of discharge, trash or litter into our waterways.

#### After fueling:

1. Tighten the fuel fill cap using the fuel cap key. Wipe up any fuel spillage.
2. Open all windows, hatches, doors and compartments.
3. Check all fuel lines, hoses and connections for leaks and deterioration.
4. Be sure to run the blower for at least four minutes before starting the engines. If you smell gasoline fumes, do not start the engines; continue to run the blower until fumes have dissipated.

#### Launching

##### Launching Checklist

Federal and local laws require certain safety equipment to be on board at all times. In addition, responsible boaters carry other equipment in case of an emergency. Check with local boating authorities for any additional requirements over and above federal requirements.

For maximum enjoyment and safety, check each of these items BEFORE launching:

- Install drain plug.
- Have enough life-saving devices for every person onboard.
- Be sure the steering system operates smoothly and properly.
- Verify the amount of fuel in the fuel tanks.
- Verify the batteries are fully charged.
- Check weather conditions.
- Be sure the lights, horn, bilge pumps and other electrical equipment are in operating conditions.
- Be sure the fire extinguisher, signaling devices and other emergency gear are onboard and in proper operating condition.

#### On the Water

Start your engines before casting off. Remember, the boat turns from the stern; therefore, allow plenty of space between the boat and the dock before trying to move away.

## Boarding

When boarding the boat, always step in. Do not jump. Avoid stepping on fiberglass or other potentially slippery surfaces. Board one person at a time.

Do not board the boat while carrying gear. Set the gear on the dock, board the boat and then pick up the gear.

## Loading



### WARNING

All passengers should be carefully seated while the boat is moving. Do not seat on the bow, bow pulpit, deck, gunwale or two stern sundeck pads when the boat is moving.

Do not overload your boat. The performance of your boat is dependent on load weight and distribution. Passengers should distribute themselves to maintain trim. Remember to distribute weight from right to left, and also from front to back.

- Avoid excess weight in the bow or stern.
- Securely stow all extra gear in stowage areas to prevent load shifting. Do not stow gear on top of safety equipment; safety equipment must be quickly accessible.
- In adverse weather, reduce the load in the boat. People/load capacity ratings are based upon normal boating conditions.
- Do not use the drive units as a boarding ramp, use the boarding ladder. To prevent injury, make sure the engines are OFF when swimmers, drivers and skiers are boarding.

Overloading of passengers, personal equipment and supplies could result in an accident, especially in rough waters. Maintain a balanced load at all times.

## Shipshape

Keep the weight distributed evenly. Store all gear in secure areas. Safety equipment must be immediately accessible at all times.

## GETTING UNDERWAY

There are many things to consider to make your boating trip safe and enjoyable. You are responsible for the safety of all passengers, the boat and any damage the boat or its wake may cause. Keep passengers from blocking your view so that you do not run into other boats, swimmers, water skiers, personal water vehicles or aids to navigation.

### Before Starting Checklist



### WARNING

Do not operate the boat if any problem is found during this inspection. A problem could lead to an accident during the outing causing severe injury or death. Have any problem attended to by your Cobalt dealer.

The following checks are essential to safe boating and must be performed before starting the engines. Get into the habit of performing these checks in the same order each time so that it becomes routine.

### Pre-Operation:

- Refer to **Before Every Use**, in **Section 5**.
- Refer to **Launching Checklist**, in this section.
- Test operation of carbon monoxide detectors.
- Open all seacocks and check for leaks.
- Check seawater strainers for leaks and accumulation of debris.
- Open windows, doors and hatches.
- Check that no fuel, oil or water is leaking or has leaked into the bilge compartment.
- Check all hoses and connections for leakage and damage.
- Verify the shift levers are in the neutral position.
- Check that the steering system operates properly.

# Operating Information

- Operate bilge blowers for at least four minutes before starting the engines or generator.
- Do not overload your boat.

## During Operation:

- Check gauges frequently for signs of abnormal operation.
- Check that steering, shift and throttle controls continue to operate smoothly.
- Check for excessive vibration.
- Monitor your fuel supply.
- Verify charging of the batteries.

## After Boating:

- To prevent marine growth from accumulating on the hydraulic cylinder shafts, make sure trim tabs are UP and propulsion unit drives are in the full IN position.
- Remove the ignition keys.

- Stow and secure all equipment.
- Pump bilges dry with manual switch.
- Close all water inlet seacocks.
- If possible, inspect the hull and propellers for damage.
- Check for fuel, oil and water leakage.
- Clean any spills, stains or moisture from the boat. Inspect sea strainers.
- Turn battery select switches off.
- Turn off DC breaker on electrical panel and if not using shore power, turn off AC breaker.
- Remove any food, garbage and wet gear from the boat.
- Secure lockers, hatches and canvas as equipped.

## Instrumentation

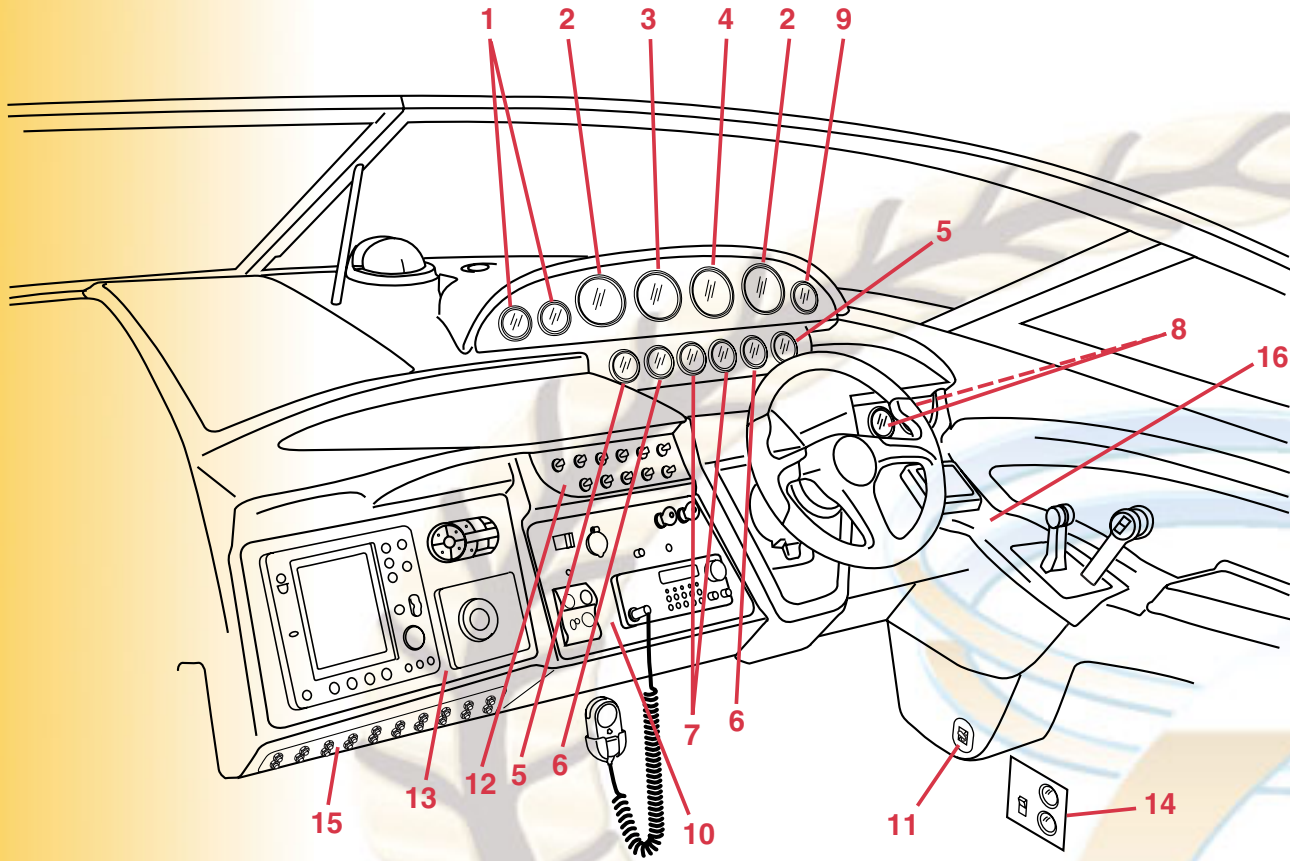

COB001

- 1. Fuel Level
- 2. Tachometer
- 3. Speedometer
- 4. Engine Synchronizer
- 5. Temperature
- 6. Voltmeter
- 7. Oil Pressure
- 8. Water Pressure

- 9. Depth
- 10. Ignition Switch Panel
- 11. Ignition Safety Switch
- 12. Main Switch Panel
- 13. Radar Panel
- 14. Generator Control Panel
- 15. Circuit Breaker Panel
- 16. Shift/Throttle Control Panel

## Gauges

Your Cobalt 360 Performance Cruiser is equipped with two sets of gauges. The port set is for monitoring operation of the port engine. The starboard set is for monitoring operation of the starboard engine. The gauges are illuminated for night operation.

On occasion, a small fluctuation in a gauge reading is not unusual. If an instrument reading is outside the normal or recommended ranges, determine the cause or see your Cobalt dealer. Refer to the propulsion unit operator's manual for normal recommended ranges.

## Fuel Level Gauge

Measures approximate level of fuel in a fuel tank. The left gauge indicates the fuel level in the port fuel tank. The right gauge indicates the fuel level in the starboard fuel tank. The ignition switch must be in the RUN position to activate the gauge. Since the accuracy of your gauge varies with attitude of your Cobalt boat (trim and list), and the fuel pick-up tube cannot withdraw all fuel out of the tank, please observe the One Third Rule. Use one third of your fuel to go out, one third to come back and one third as a reserve.

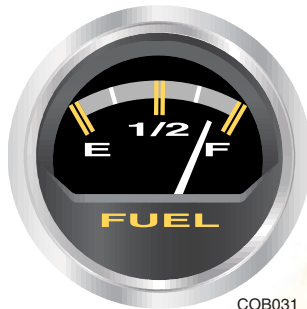

COB031

## Tachometer

Registers engine speed in revolutions per minute (RPM). Use this gauge to keep the engine within the proper operating range. Consult your propulsion unit operator's manual for the proper RPM operating range for your engines.



COB032

## Speedometer

Registers forward speed in miles per hour. Use this gauge to monitor fuel consumption and propeller performance. Since its input is received from a water pressure hose, accuracy is only approximate.

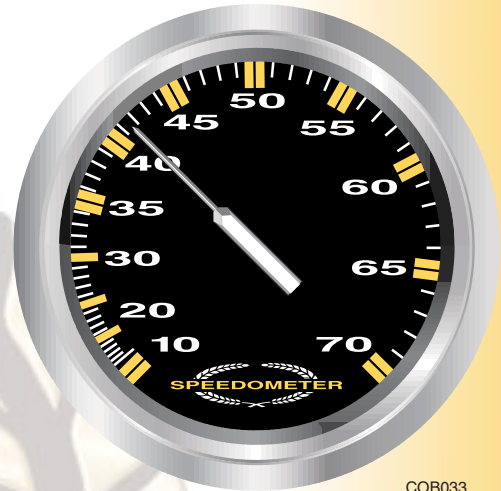

COB033

## Engine Synchronizer

Compares both engine RPMs. When the gauge needle points to zero (straight up), the engines are running at the same rate and are in "sync" with each other. When the needle points to either side of zero, one engine is operating at a higher RPM than the other. The situation is corrected by adjusting one or both throttles until the engines are in sync and the needle points to zero.



COB034

### Engine Water Temperature Gauge

Indicates the water/coolant temperature inside the engine. Refer to the propulsion unit operator's manual for normal operating temperature. After starting the engine, check your temperature gauge for abnormally high readings. If the reading is outside the manufacturer's operating range, immediately turn off the engine. An abnormally high temperature is the result of cooling water blockage. Consult your Cobalt dealer when experiencing a high engine temperature reading.

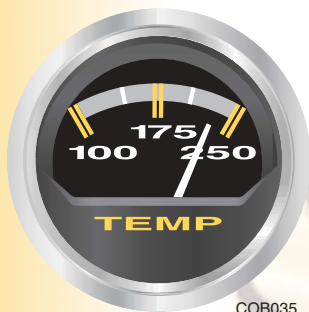

COB035

### Voltmeter

Indicates the condition of the engine's cranking battery in volts DC. With the ignition switch on and the engine not running, a reading between 11.5 and 12.5 volts indicates a fully charged battery. With the engine running at idle, the gauge should read between 10 and 12 volts. With the engine running at cruising speeds and above, it should show 12 to 14 volts. Have your Cobalt dealer check the charging system if the voltmeter reads below these normal ranges.

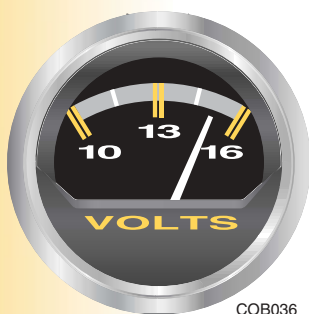

COB036

### Engine Oil Pressure Gauge

Measures the pressure of the engine's lubricating oil. Refer to the propulsion unit operator's manual for normal operating pressure. Many serious engine problems are reflected on oil pressure gauge readings. If the pressure is lower than the manufacturer's specification, immediately shut off the engine. Have your Cobalt dealer correct the problem before operating the engine.



COB037

### Engine Water Pressure Gauge

Registers the engine's cooling water circulating in pounds per square inch (PSI). Refer to the engine operator's manual for correct specifications. Use this gauge to determine if the engine cooling water is properly operating.



COB038

### Digital Depth Gauge

Displays the depth of the water under the boat. To avoid running aground in shallow water, add distance to the meter reading and maintain a very slow speed. The depth gauge features an audible and LCD displayed depth alarm with adjustable shallow and deep limits.

Refer to the depth gauge instructions supplied in your owner's packet for operating information.



COB039

## Hour Meter

An hour meter for each engine is located within the engine compartment. The hour meter accumulates the operating hours of an engine.

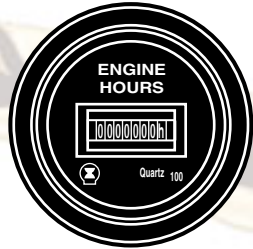

KC-0782

## Ignition Switch Panel

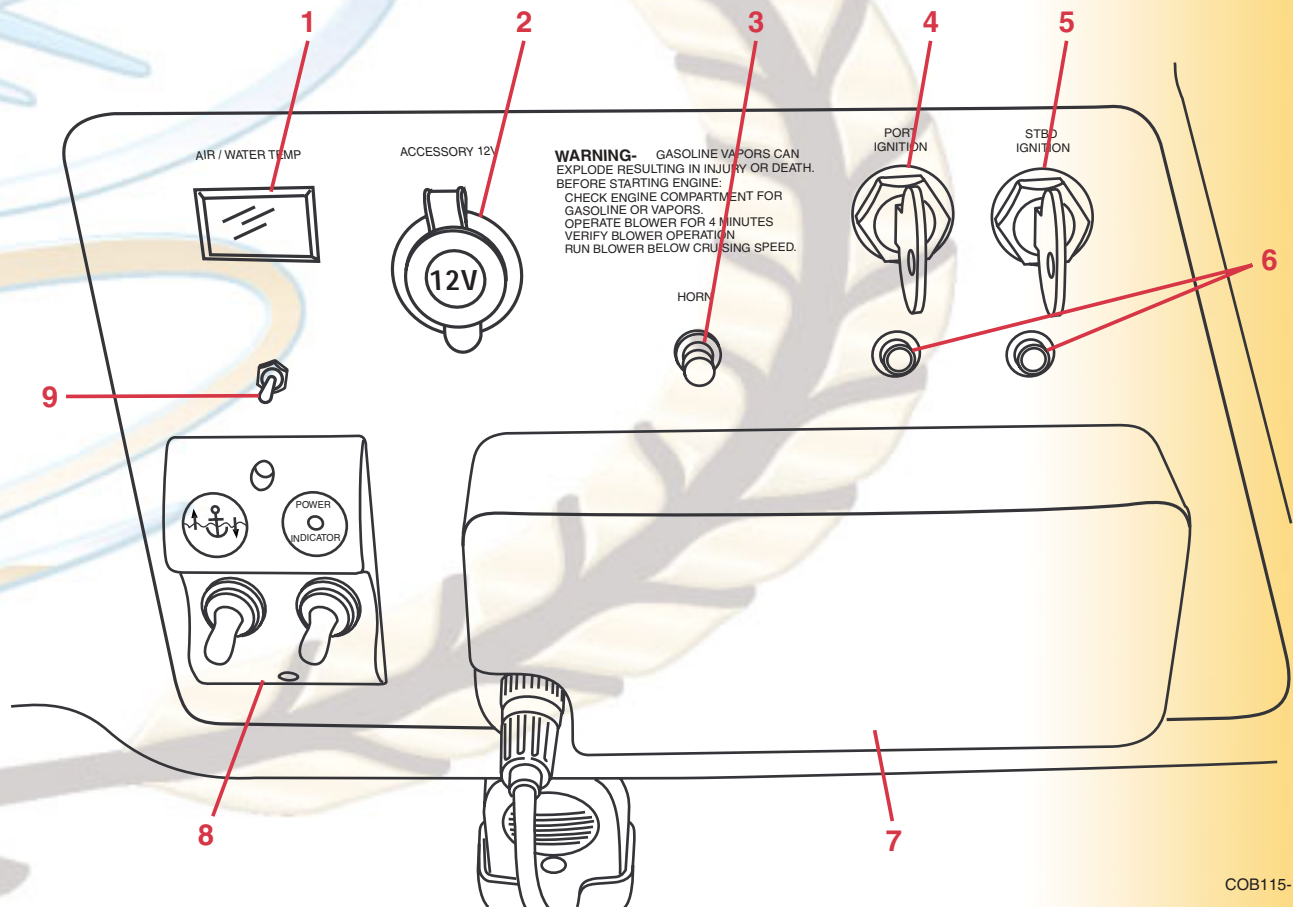

COB115-1

1. Air/Water Temperature Gauge
2. 12-Volt Accessory Power Receptacle
3. Horn Button
4. Port Ignition Switch
5. Starboard Ignition Switch

6. Ignition Breakers
7. VHF/FM Radio
8. Windlass Control Panel
9. Air/Water Temperature Gauge Switch

### Air/Water Temperature Gauge

Moving the toggle switch below the air/water temperature gauge allows you to go between air and water temperature readings. The gauge will display AIR and WATER to indicate which temperature source is in use. For additional information, refer to the air/water temperature gauge operating instructions in your owner's packet.

### 12-Volt Accessory Power Receptacle

Your Cobalt 360 Boat is equipped with a 12-volt accessory power receptacle. The receptacle provides electricity to operate 12 VDC accessory items.

### Horn

Pushing in the button will activate the horn.

### Ignition Switches

Each engine has its separate ignition switch. The left switch is for the port engine, and the right switch is for the starboard engine.

### Ignition Breakers

Press to reset. If the button continues to pop out, consult your Cobalt dealer.

### VHF/FM Radio

The optional 12 VDC VHF/FM marine radiotelephone provides reliable communications between boats, and between a boat at sea to public and private shore stations. For additional information, refer to the radio operating instructions in your owner's packet.

### Windlass Control

The Windlass system can be electronically operated from the helm. For operation of the Windlass system, refer to **Anchoring**, in this section.

### Ignition Safety Switch

**CAUTION**

**Do not allow your Cobalt boat to be operated without the proper use of the ignition safety switch and lanyard.**

Your Cobalt boat is equipped with an ignition safety switch located on the lower lip of the dashboard. The ignition safety switch and lanyard will stop the engines in case of an emergency. Attach the lanyard to the boat operator whenever

the engines are running but be aware there will be a loss of boat control if the switch is activated. If the operator is thrown from the seat or moves too far from the helm, the lanyard will become disconnected from the ignition safety switch, shutting off the engines.

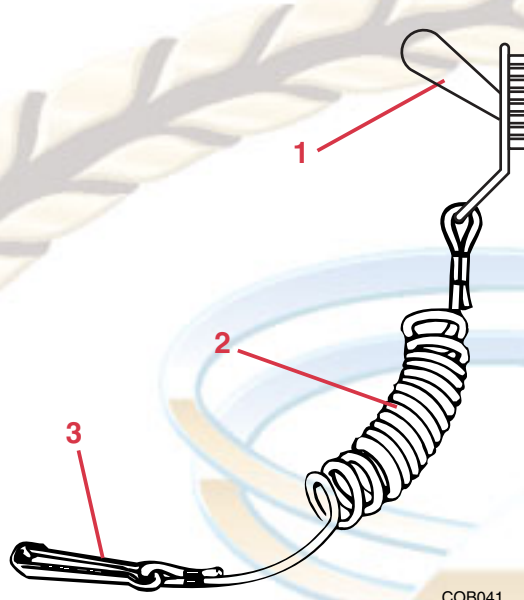

1. Ignition Safety Switch
2. Lanyard
3. Hook

To attach the lanyard, connect the clip to the ignition safety switch and the hook to a strong piece of clothing on the operator, such as a belt loop.

**! WARNING**

**Attach the ignition safety switch lanyard to the operator before starting the engines. This will prevent the boat from becoming a runaway if the operator is accidentally thrown away from the helm.**

**! WARNING**

The ignition safety switch can only be effective when it is in good working condition. Observe the following:

- Do not remove or modify the ignition safety switch and/or lanyard.
- The lanyard must be free from obstructions that could interfere with its operation.

## Main Switch Panel

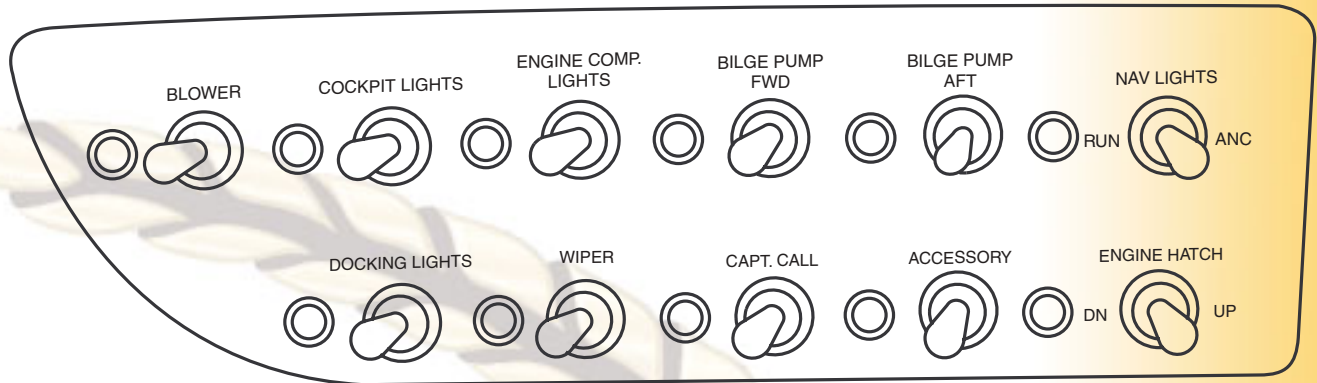

COB042

Each electrical circuit on your Cobalt 360 boat is equipped with a control switch.

The main switch panel is located on the helm to the left of the steering wheel. When a switch is activated, the red light to the port will turn on.

### Blower Switch

#### **WARNING**

Failure to operate the blower can lead to conditions favorable for an explosion which can cause severe personal injury or death.

Activates the engine compartment ventilation blower to remove explosive fumes from the area.

The blower must be operated for a minimum of four minutes each time before starting the engines or generator. In addition, the blower should be operated continuously when at idle or running at slow speeds.

### Cockpit Lights

This switch operates the interior courtesy lighting.

### Engine Compartment Lights

This switch provides illumination within the engine compartment.

### Forward Bilge Pump

This switch manually controls the forward bilge pump.

### Aft Bilge Pump

This switch manually controls the aft bilge pump.

### Navigational Lights

This three position switch activates the navigational (running) lights and the anchor light. Move the toggle toward the “RUN” symbol to activate the operating at night navigational lights. The center position is OFF. Move the toggle toward the “ANC” symbol to activate the all around white anchoring light.



**NOTICE:** Operate the boat between sunset and sunrise using your navigational lights. Navigational lights are legally required to indicate direction and right-of-way at night.

Navigational Lights - You must use your navigational lights (running lights) when operating your Cobalt boat between sunset and sunrise, and when day time visibility is limited. Also, check with the local authorities before operating your boat for other requirements concerning the use of navigational lights.

The navigational lights are identified by a red light on the port side of the vessel, and a green light on the starboard side.

Anchor Light - All boats at anchor must display a proper white anchor light. The anchor light (all around light) is the white light located on top of the radar tower. The anchor light must be visible 360 degrees and will remain on when operating the navigational lights.

### Docking Lights

This switch operates the docking lights. Docking lights are to be used for docking only. It is illegal to use your docking lights while cruising.

### Wiper

This switch activates the windshield wiper.

### Exhaust Diverter

This switch controls the exhaust direction on the optional exhaust diverter system. The exhaust diverter system switches the output of the engines exhaust either to thru-hull exhaust pipes (above water) or down through the propeller hub (below water). The CAPT. CALL switch on the main switch panel determines the routing of the engine exhaust.

In the ON position, engine exhaust is routed through the hull pipes. This position produces the most engine power, but is not acceptable near shore or on inland lakes and rivers.

In the OFF position, engine exhaust is routed down through the hub of the propeller. This position releases the exhaust underwater providing a quieter engine sound.

Be sure to check local regulations regarding noise restrictions before operating this system.

### CAUTION

To avoid damage to the exhaust system, do not switch the exhaust above 3,000 RPM.

### Accessory

This switch is available to operate an accessory item.

### Engine Hatch

This switch activates the engine compartment hatch electronic lift system. If the battery is low, use the jump start studs to raise the compartment. If the battery is disconnected or low on power, the hatch can also be raised manually.

The engine compartment handle is located beneath the rear starboard seat cushion.



COB134

1. Support Pole

### ! WARNING

Before working in engine compartment with hatch raised, install support pole securely.



COB143

Insert handle into engine compartment receiver. Turn knob on handle clockwise to thread it into place. Pull up and raise the engine compartment.



COB125

## Radar Panel

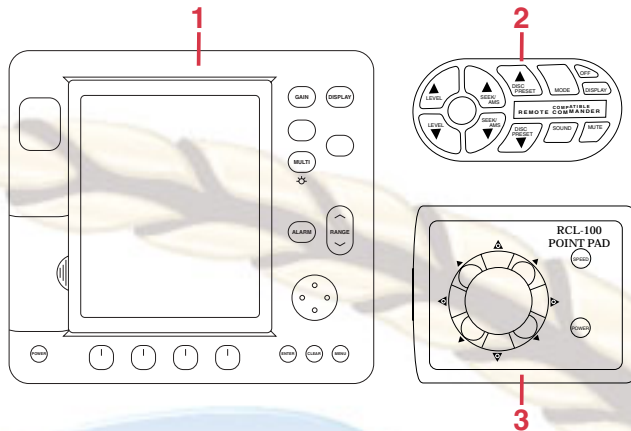

COB116

1. Combination GPS/Radar Unit
2. Stereo Remote Control
3. Search Light Control

### Combination GPS/Radar Unit

The optional global positioning satellite (GPS) system performs many functions. The system can precisely indicate your location, form a trip record or a speed log. In addition, individual mapping chips can be purchased through your Cobalt dealer for most lakes, rivers and coastal areas of the U.S. and Canada. Please consult your Cobalt dealer for further information referencing these chips.

Take some time to thoroughly read and understand the manuals supplied with your GPS to take advantage of the system to its fullest capability.

### Stereo Remote Control

This panel provides remote control of the stereo system from the helm.

### Search Light

All functions of the optional search light can be electrically operated by remote control from the helm using the remote control panel. For additional information, refer to the search light operating instructions in your owner's packet.



COB072

## Generator Control Panel

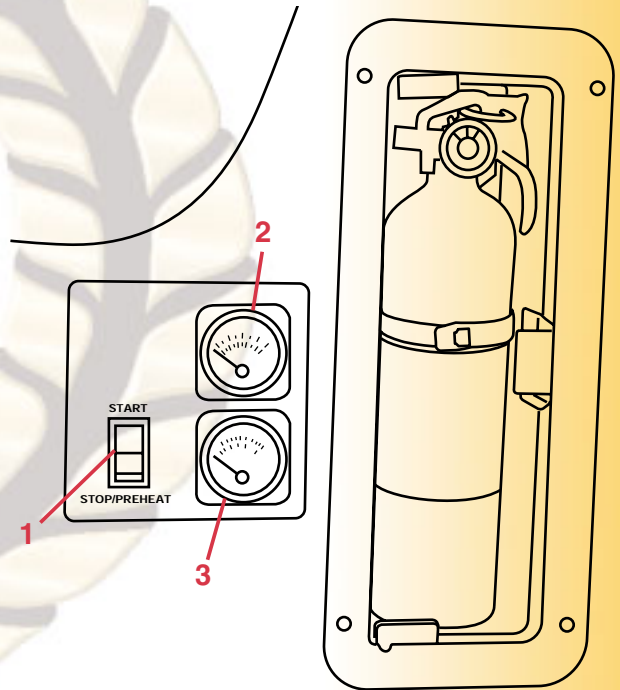

COB005

1. Start/Stop Switch
2. Oil Pressure Gauge
3. Water Temperature Gauge

The control panel for the optional generator is located on the starboard side panel at the helm. The panel consists of the start/stop switch, oil pressure gauge and water temperature gauge.

## Circuit Breaker Panel

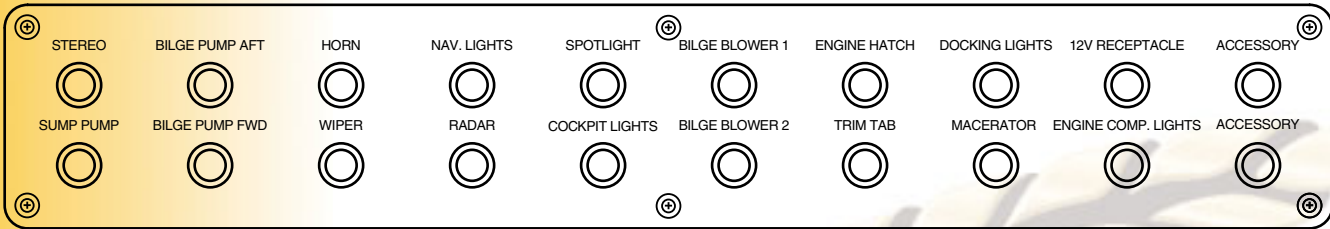

COB008

The circuit breaker panel is located on the lower port side of the helm. Most electrical standard equipment devices are controlled with circuit breakers. These breakers will activate if overloaded and cut power to the switch. To restore power, push the breaker button in and release. If the button continues to pop out, consult your Cobalt dealer.

## Battery Switch Panel

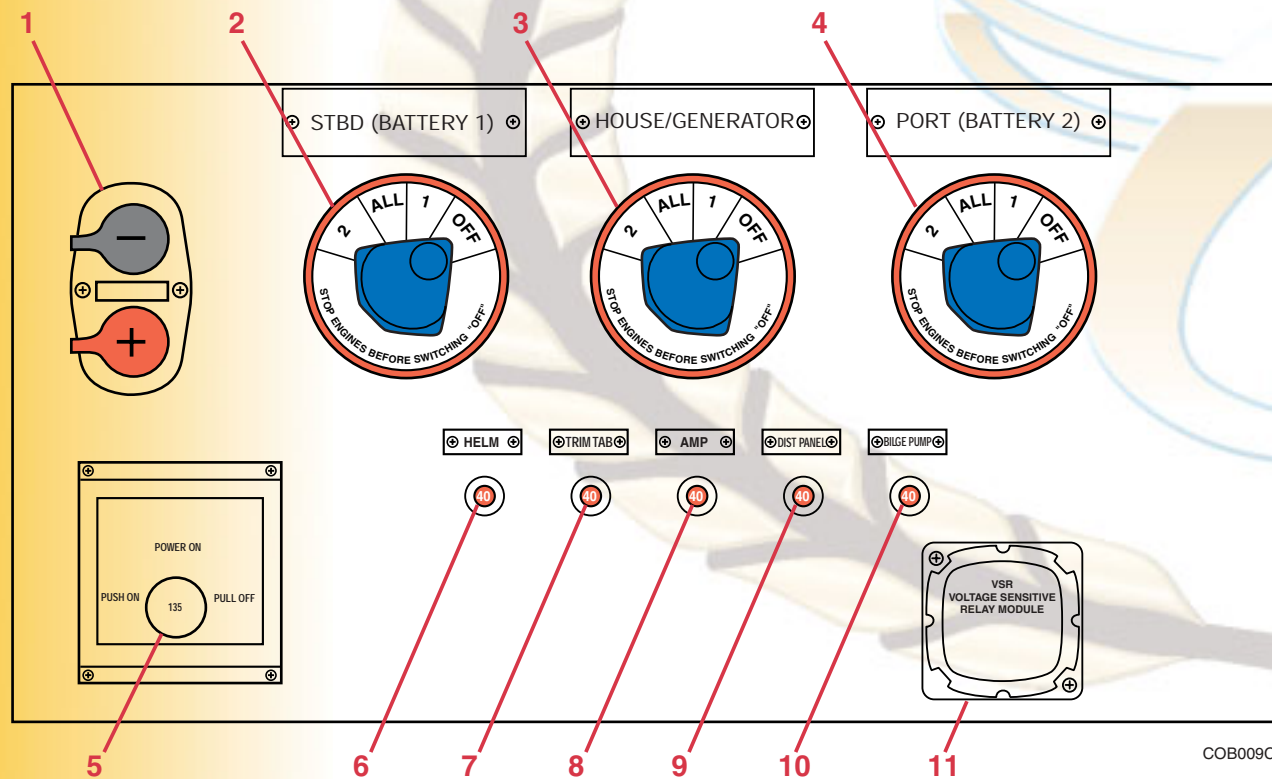

COB009C

- |                                    |                                 |
|------------------------------------|---------------------------------|
| 1. Jump Start Studs                | 7. Breaker – Trim Tabs          |
| 2. Starboard Engine Battery Switch | 8. Breaker – Amp                |
| 3. Generator Battery Switch        | 9. Breaker – Distribution Panel |
| 4. Port Engine Battery Switch      | 10. Breaker – Bilge Pump        |
| 5. Windlass Breaker/Switch         | 11. Voltage Relay               |
| 6. Breaker – Helm                  |                                 |

## Jump Start Studs

This receptacle allows for “jump starting” of the engines. The receptacles have protective covers. Be sure covers are installed when receptacles are not being used. These can be used, when the batteries are low or removed, to raise the engine compartment.

## Battery Switches

### **WARNING**

**Do not turn a battery switch to the OFF position while the engine is running. Serious electrical system damage could occur.**

Your Cobalt 360 Performance Cruiser is equipped with three battery switches located under the aft port cockpit seat cushion in the rear of the boat. The battery switch connects one or two batteries to the electrical circuit of an engine or generator. The switch provides isolation and positive disconnect of the battery to protect against tampering, electrical fire hazards and battery rundown. Rotate the switch to the OFF position when the boat is not in use.

The starboard battery switch is connected to the starboard engine’s charging system. The center battery switch is connected to the generator’s charging system and cabin 12 VDC components. The port battery switch is connected to the port engine’s charging system. Refer to the battery switch user’s manual for additional information.



**NOTICE: The automatic bilge pump circuit will remain energized even with the battery switches in the OFF position.**

## Windlass Breaker

This breaker must be on for windlass operation.

## Circuit Breakers

These five 40-amp circuit breakers protect the following circuits:

- Helm
- Trim Tabs
- Amp
- Cabin Distribution Panel
- Bilge Pumps

Locate and correct the cause of a tripped breaker, push to reset. If the button continues to pop out, consult your Cobalt dealer.

## Voltage Relay

Allows the starboard engine alternator to charge the house battery automatically.

## Shift/Throttle Control Panel

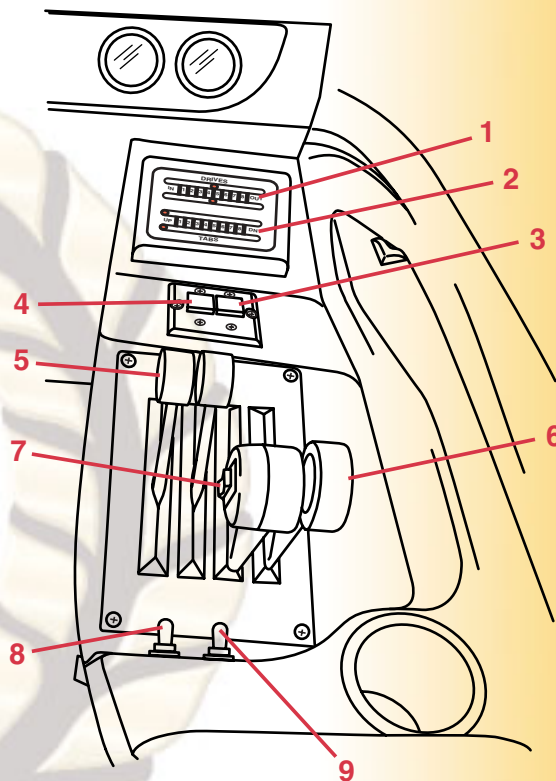

COB006

1. Drive Unit Trim Indicator
2. Trim Tab Indicator
3. Port Trim Tab Switch
4. Starboard Trim Tab Switch
5. Shift Levers
6. Throttle Levers
7. Combination Port and Starboard Drive Units Trim Switch
8. Port Drive Unit Trim Switch
9. Starboard Drive Unit Trim Switch

## Indicators

The indicators display the relative position of the drive units and trim tabs. The top indicator set displays the IN and OUT position of the drive units. The bottom indicator set displays the UP and DOWN position of the trim tabs.

### Individual Drive Unit Trim Switches

Individual trim switches are provided to separately operate the port and starboard drive unit trim.

### Combination Port and Starboard Drive Unit Trim Switch

This switch operates both the port and starboard drive unit trim together.

### Trim Tab Switches

The right switch activates the port trim tab. This tab controls the starboard bow movement of the boat. The left switch activates the starboard trim tab. This tab controls the port bow movement of the boat.

### Remote Controls

#### WARNING

Improperly maintained controls are hazardous and may cause sudden loss of control. Make sure all shift/throttle hardware and cables are regularly inspected and maintained. Improper maintenance may result in a loss of control, resulting in serious injury or death.

#### CAUTION

Do not shift too quickly from forward to reverse. Damage to the engines may result. When shifting from forward to reverse, pause in neutral until the engines are at idle speed and the boat has slowed.



**NOTICE:** Your Cobalt boat is equipped with a safety switch for “start-in-neutral-only” operation. Be sure the shift levers are in neutral before attempting to start the engines.

The following information relates to the general description about your controls. Refer to the propulsion unit operator’s manual or the control operator’s manual for specific use.

Your controls have individual levers for drive unit shift and engine throttle for each engine. The left levers are for the port engine and the right levers are for the starboard engine. The controls are

arranged with the shift levers (all one size and color) grouped together and throttle levers (all the same size and color, and larger than the shift levers) grouped together.

### Electronic Control

Your Cobalt 360 Performance Cruiser may be equipped with an electronic shift/throttle control. This control has an automatic synchronization feature which increases fuel efficiency and reduces vibration and noise.

Other features include warm-up and single lever control.

For complete details on the electronic control and to understand all procedures and functions, refer to the manufacturer’s operation manual before operating the vessel.

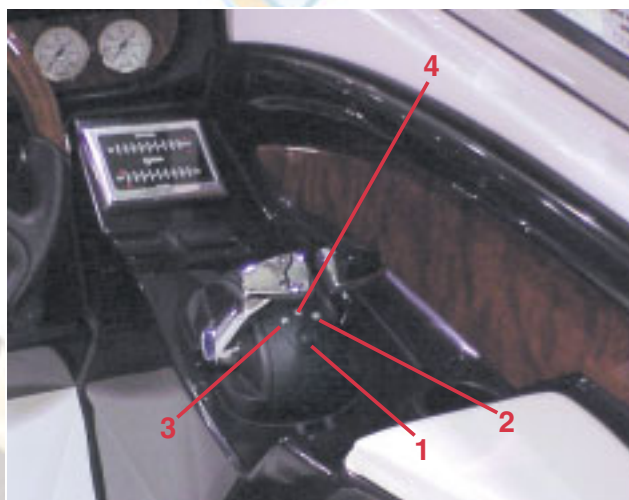

COB151

1. Station Transfer Button
2. Starboard Station-in-Command Indicator Light
3. Port Station-in-Command Indicator Light
4. Synchronization Indicator Light

### Equipment

The following information describes how standard and optional equipment interfaces with your Cobalt 360 Performance Cruiser.

#### Air Pump

The air compressor is located beneath the port sun lounge cushion. It uses the 12 VDC system and will operate when the AIR COMPRESSOR switch at the cabin distribution panel is turned on. For additional information, refer to the air compressor operator’s manual in your owner’s packet.



COB144

## Air Conditioning/Heating

The Heating, Ventilation and Air Conditioning (HVAC) system supplies both heating and cooling to the cabin using a heat pump system, and operates on 110 VAC supplied by shore power or the generator. The system controller is located in the panel with the cabin entertainment system. The system must be properly winterized for storage to prevent damage. For additional information, refer to the air conditioning operating instructions in your owner's packet. To operate the HVAC system:

1. Open the seacock forward of the starboard engine.
2. Turn ON the "MAIN" and "AIR CONDITIONER" circuit breakers located on the cabin distribution panel.
3. Set the "AUXILIARY POWER" rotary switch to "SHORE 1 or 2" as appropriate.
4. Turn HVAC system on by pressing appropriate buttons on the controller and adjust settings as needed.

## Cabin Entertainment System

Includes DVD player and stereo. There are separate instructions provided in your owner's packet for operating the entertainment system equipment.



COB074

The stereo is located in the cabin, forward of head, behind top wooden door. Take care to pull door toward you until it is level and then slide back into recess. To operate the stereo:

1. Turn battery switches ON; light will illuminate on stereo.
2. Press lighted button to open stereo faceplate and access controls.

The DVD player is located above the stereo in cabin. To operate the DVD player:

1. Turn ON the 12-volt "MAIN" and "ACC" breakers located on the cabin distribution panel.
2. Audio may be played through stereo by pressing "SOURCE" button until "CD" is displayed and then "MODE" until "CD3 AUX PLAY" is displayed (CD1 is stereo CD, CD2 is the changer and CD3 is auxiliary source).

### Boarding Ladder



COB111

The telescoping boarding ladder is covered by the ladder lid. Lift the ladder lid to access the ladder. Lift up on the front of the ladder to place it overboard and telescope to full length. Use caution to prevent pinching your fingers when stowing the ladder.

### Aft Speakers (Optional)



COB145

The optional speakers are located in the port and starboard rear compartments. A switch is located in the port compartment to turn speakers on or off, as desired.

### Bow Sun Pad



COB142

1. Holder
2. Strap

Slide the sun pad into the forward holder and secure with the straps to the two hand rails to hold the pad in position.

### WARNING

**Do not allow passengers to sit on the bow sun pad when the boat is underway.**

### Cabin Access Door

Secure the door before operating the boat. When in the open position, use the door stop.

### Cabin Table



COB126

The cabin table can be lowered to allow installation of the optional filler cushions to create a sleeping berth. The short post is stored under the port cabin seat bottom with additional support

bars. Install bars in notches under the aft end of the cabin cushion. The optional filler cushions are stored under the starboard seat cushion.



COB135

## Captain's Chair

Your captain's chair has a flip-up bolster position for greater visibility and maneuverability while docking. You can sit on the raised cushion or stand in front of the cushion. Standing while driving your boat should only be done while maneuvering at an idle by an experienced driver.



COB112

### 1. Lever

For fore and aft seat adjustment pull the lever beneath the seat.

## Carbon Monoxide Detector

There are two carbon monoxide detectors; one unit is in the main cabin and another in the mid-berth. Both detectors receive their power from the 12 VDC system through the battery switches. Units will be operational any time the battery switches are on.

If occupying the boat, turn the battery switches ON. The green light on the detector may flash for 15 minutes while unit warms up, however the unit is fully functional. If the unit alarm sounds, evacuate all persons from the cabin area to fresh air immediately and investigate the cause. Do not return to the cabin area until the cause of the CO has been identified and corrected.

## WARNING

**Test the carbon monoxide detector operation before each trip, at least once a week and after the boat has been in storage. Do not tamper with the operation of the carbon monoxide detectors. They are installed for your safety.**

For additional information, refer to the carbon monoxide detector operating instructions in your owner's packet.

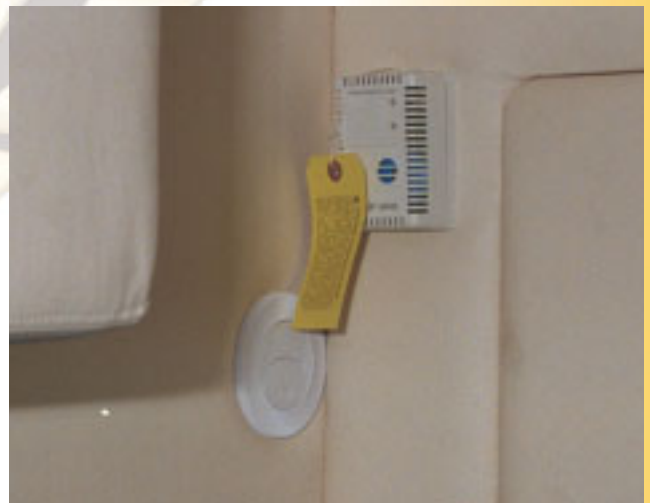

COB110

### Cockpit Table



COB129

Your cockpit table is stored in the generator area beneath the cockpit floor. The table support arm is stored under the starboard cockpit seat cushion.

To install the table, open the cover on receiver located below the center starboard seat. Insert the table bracket into the receiver.



COB136

#### 1. Thumb Screws

To remove the table, unscrew thumb screws. Pull the table from the receiver and close the cover.

### Compass

To aid in navigation, your Cobalt boat has a compass mounted at the helm. Refer to the compass user's manual supplied in your owner's packet for operating information.



COB108

### Hot Water Tank

The six-gallon hot water heater unit operates in two modes. If your boat is connected to shore power (110 VAC), or the optional generator is running, simply energize the appropriate switches on the cabin distribution panel and the switch marked WATER HEATER.

When the engines are operating, engine coolant (hot water) is circulated through a coil in the water heater, heating the fresh water. Note the hot water system as well as the entire fresh water system in your Cobalt boat must be winterized for proper storage.

**⚠ WARNING**

**Do not smoke or have any flame near an open faucet; hydrogen gas is extremely flammable.**

Water heaters unused for more than two weeks may produce hydrogen gas.

To reduce the risk of injury under these conditions, open the hot water faucet for several minutes at the kitchen sink before you use any electrical appliance connected to the hot water system.

If hydrogen is present, you probably will hear unusual sounds like air escaping through the pipe as water begins to flow. Allow the water to flow until these sounds disappear.

## Icemaker

The icemaker is located under the cockpit galley sink and operates on 110 VAC supplied by shore power, the generator, or the inverter. The icemaker uses water from the freshwater tank which must also be activated to make ice. When mooring or storing the boat, empty the ice bucket completely. To operate the icemaker:

1. Turn ON the "MAIN" and "OUTLET" circuit breakers located on the cabin distribution panel.
2. Turn ON the 12-volt "MAIN" and "WATER PRESSURE" circuit breakers located on the cabin distribution panel.
3. Turn ON the switch under the door on the icemaker.



COB069

## Microwave

The microwave operates on 110 VAC when the optional generator is running, the inverter is being used or the boat is connected to shore power with the appropriate switch energized. For additional information, refer to the microwave operating manual in your owner's packet.



COB147

## Refrigerator/Freezer

The refrigerator/freezer receives its power from the 12 VDC electrical system. The electrical system must be energized correctly at the cabin distribution panel. The 12 VDC main switch must be turned on as well as the switch marked REFRIGERATOR.

The thermostat control is inside the refrigerator. For additional information, refer to the refrigerator operator's manual in your owner's packet.

## Shower

With the ship's water system turned on, the shower can be used by raising the nozzle of the head sink faucet.

## Stove

The cabin-mounted, single burner, electric stove operates only on 110 VAC when the optional generator is running, the inverter is being used or the boat is connected to shore power with the STOVE switch on. For additional information, refer to the stove operator's manual in your owner's packet.



COB075

## Television

The television is located in the cabin, forward of head, optional in the mid-berth area and operates on 110 VAC supplied by shore power, the generator, or the inverter. To operate the television:

1. Turn ON the “MAIN” and “ACC” circuit breakers located on the cabin distribution panel.
2. Turn power ON by sliding the red button, located at the top right corner of television, to the right.

Power to unit cannot be turned on with remote but can be controlled by remote, once power is on. Optional mid-berth television is operated similarly.

### Sun Lounge



COB131

The back of the sun lounge can be moved to the relaxed position by pulling it straight up and rotating it toward the bow.



COB132

### WARNING

**Do not allow passengers to sit on the two stern sundeck pads when the boat is underway.**

### Arch Antenna and Gain Control

The TV antenna utilizes a gain control for optimum reception. The control is mounted in the cedar hanging closet in the cabin. Rotate the knob to adjust gain for maximum reception. When using shore “Cable TV” hook up, make sure gain is OFF by rotating knob fully counterclockwise.



COB148

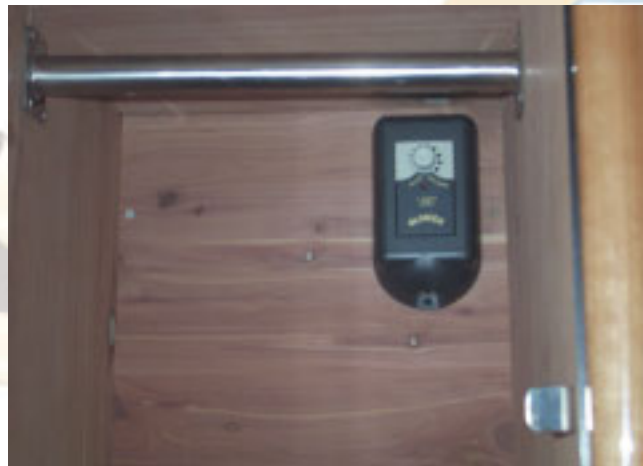

COB149

## Handling Dock and Mooring Lines

Be sure to use enough fenders to protect your boat from damage. Only use good quality double-braided nylon line. Use chafing protectors on the lines to protect your boat's finish. Only use the cleats, bow eye and stern eyes to secure your boat. Do not use the hand rails or windshield. If possible, tie up your boat with the bow toward the waves and leave a little slack in the lines to allow for some wave movement or tidal action.

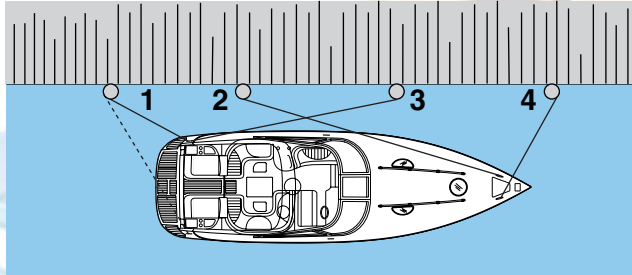

COB047C

1. Stern Line
2. Forward Quarter Spring
3. After Bow Spring
4. Bow Line

Use your dock lines to help maneuver the boat near the pier and to secure it. Use the following information to secure your boat to a pile or dock cleat:

The bow line is fastened to the bow cleat and is pulled forward at about a 45° angle. This line keeps the boat from moving astern.

The stern line is fastened to an after cleat and pulled astern at about a 45° angle. This line keeps the boat from moving forward.

The spring lines can help you control the boat when leaving a dock. Be sure to use spring lines when boating in waters where the tide movement is significant. The forward quarter spring line is fastened to a forward cleat and heads aft. The after bow spring is fastened to a stern cleat and heads forward.

## Starting/Shifting/Steering/Stopping

Your Cobalt 360 Performance Cruiser may be equipped with a warning system that will sound an alarm if an engine problem develops. The horn may emit a short chirping sound during starting to verify operation. If the warning horn sounds when operating the boat, IMMEDIATELY throttle back to idle speed and shift into neutral. IMMEDIATELY check the gauges and stop the engines.

### CAUTION

Continued operation after the warning alarm has sounded may cause severe engine damage.

### ! WARNING

Test the carbon monoxide detector operation before each trip, at least once a week and after the boat has been in storage. Do not tamper with the operation of the carbon monoxide detectors. They are installed for your safety.

## Starting Gas Engines

### ! WARNING

Operate the blower for at least four minutes each time you start the engines. In addition, the blower should be operated continuously when at idle and during slow speed operation. Failure to operate the blower can cause an explosion.

After launching and pre-start checks and procedures have been followed, the engines can be started. Please refer to the propulsion unit operator's manual for additional starting procedure information.

**! WARNING**

Start the engines with the shift control levers in neutral. Your boat is equipped with a neutral safety switch which will not allow engines to be started unless the shift control levers are in the neutral position.

1. Move both shift control levers to the neutral position.
2. Move both throttle levers to the idle position.
3. Turn the ignition key of one engine to START position. Release the key immediately after the engine starts. If the engines fail to start, refer to the propulsion unit operator's manual for additional information.

**CAUTION**

Failure to release the ignition key after the engine starts may damage the engine's starter motor.

4. Operate the engine at approximately 1,000 RPM and check the oil pressure gauge. If oil pressure is not within specified range, stop the engine immediately. Have your Cobalt dealer service the engine.
5. Repeat starting procedure for the second engine. The second engine may be difficult to hear when it starts due to the noise of the first engine. Observe the tachometer of the second engine. When the RPM's rise, release the ignition key immediately.
6. Make sure the water pressure gauge(s) indicate water pressure immediately after starting the engine(s). If they do not, turn off the engine(s) and contact your Cobalt dealer.
7. Allow the engines to warm up. Check the water temperature gauges to be sure water temperature remains within the specified range. If temperature gauge reads abnormally high, stop the engine immediately. Check the drive unit's water inlets for blockage. If the inlets are open, have your Cobalt dealer service the engine.

**Starting Diesel Engines****! WARNING**

Operate the blower for at least four minutes each time you start the engines. In addition, the blower should be operated continuously when at idle and during slow speed operation. Failure to operate the blower can cause an explosion.

After pre-start checks and procedures have been followed, the engines can be started. Please refer to the engine operator's manual for additional starting procedure information.

**! WARNING**

Start the engines with the shift control levers in neutral. Your boat is equipped with a neutral safety switch which will not allow engines to be started unless the shift control levers are in the neutral position.

1. Move both shift control levers to the neutral position.
2. Move the throttle lever of the engine to be started to approximately one-half throttle position.
3. Turn the ignition key of one engine to START position. Release the key immediately after the engine starts. If the engines fail to start, refer to the engine operator's manual for additional information.

**CAUTION**

Failure to release the ignition key after the engine starts may damage the engine's starter motor.

4. Operate the engine at approximately 1,400 RPM and check the oil pressure gauge. If oil pressure does not rise to specified range in 15 seconds, stop the engine immediately. Have your Cobalt dealer service the engine.

5. Repeat starting procedure for the second engine. The second engine may be difficult to hear when it starts due to the noise of the first engine. Observe the tachometer of the second engine. When the RPM's rise, release the ignition key immediately.
6. Make sure the water pressure gauge(s) indicate water pressure immediately after starting the engine(s). If they do not, turn off the engine(s) and contact your Cobalt dealer.
7. Allow the engines to warm up. Check the water temperature gauges to be sure water temperature remains within the specified range. If temperature gauge reads abnormally high, stop the engine immediately. Check the drive unit's water inlets for blockage. If the inlets are open, have your Cobalt dealer service the engine.

## Shifting/Running

### CAUTION

**Go slowly in reverse to avoid taking water in over the transom. You can swamp the boat by taking on too much water.**

Follow these guidelines when shifting your boat:

- Pause in neutral before shifting from forward to reverse, or reverse to forward.
- Avoid shifting into reverse while the boat is traveling forward at speed.
- Keep the control area clean and clear of obstructions.
- Do not exceed 40 MPH when the bimini enclosure is installed.

## Steering

### ! WARNING

- **The steering is the most important system in the entire boat from a safety standpoint. Have this system inspected and maintained on a quarterly basis by a qualified service technician.**
- **The boat's steering system is not self-centering. Propeller torque, trim setting, water condition and boat speed affects the steering. Constant attention to the steering system is required for safe operation.**

Your Cobalt 360 Performance Cruiser is equipped with a tilt steering wheel. Adjust the tilt position by grasping the top of the steering wheel and depressing the release lever with your thumb. Release the lever to lock the steering wheel when achieving a comfortable position.

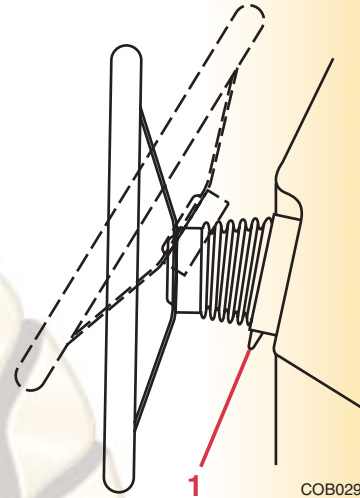

1. Release Lever

### ! WARNING

**Do not adjust the steering wheel tilt position while the boat is moving. Sudden boat movement may cause loss of balance resulting in loss of control and/or injury.**

The steering system must be working correctly and properly maintained. Be sure to:

- Keep mooring lines, tow lines and other obstructions clear of the steering system.
- Keep the steering system's moving parts clean and lubricated.
- Regularly inspect the steering system for kinks, damage and corrosion.

Refer to **Basic Maneuvering**, in this section, for additional steering information.

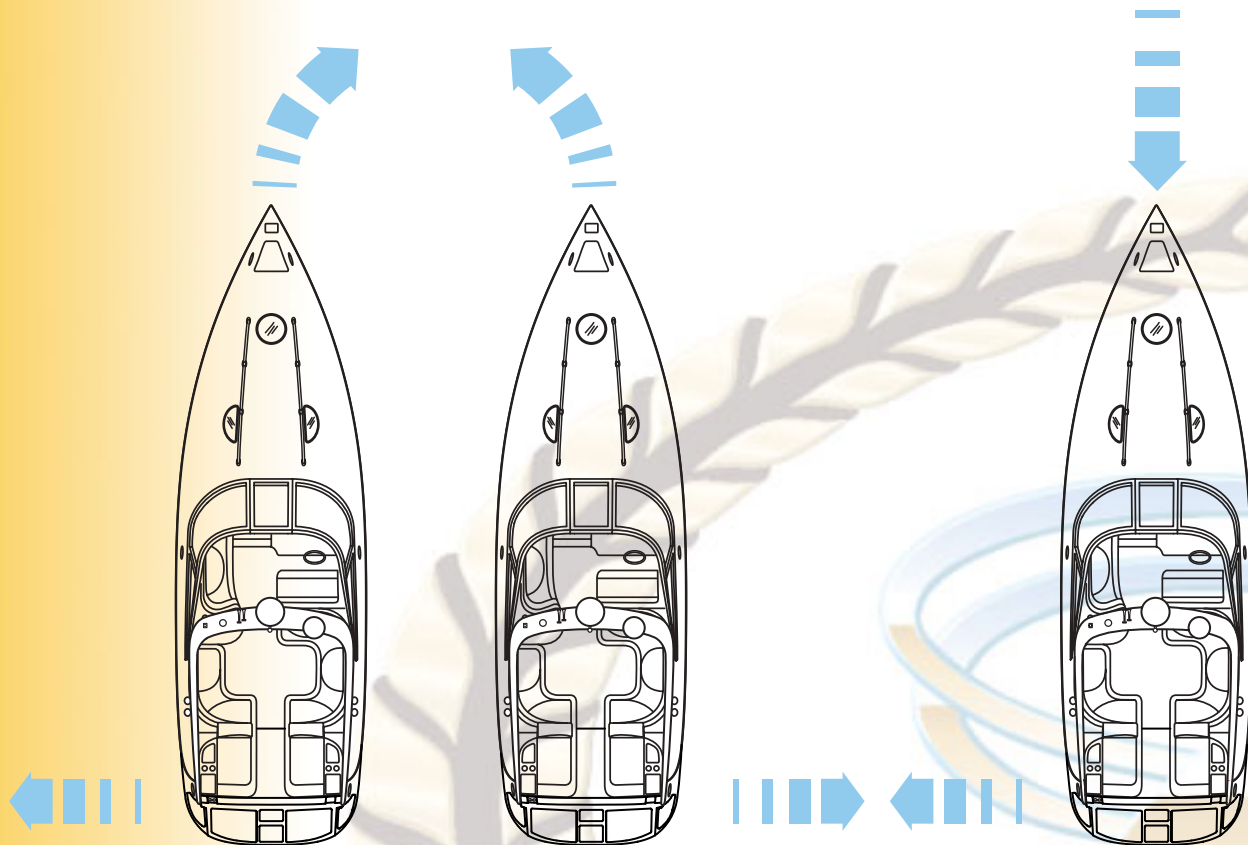

**RIGHT TURN**  
Turn wheel to right Stern will move to left.

**LEFT TURN**  
Turn wheel to left Stern will move to right.

**BACKING TO LEFT**  
Turn wheel to left Stern will pull to left.

COB046C

### Stopping Gas Engine

#### **WARNING**

**Do not use the engine stop switch and lanyard for normal stopping of the engines. Doing so will impair your ability to restart the engines quickly or may create a hazardous swamping condition.**

1. Slowly bring the throttle levers to the idle position.
2. Move the shift levers to neutral.
3. After operating at high speeds, allow a 2-3 minute engine cool-down period at low idle.
4. Turn the ignition keys to OFF position.



**NOTICE:** If any problems are encountered during the outing, have your boat inspected by your Cobalt dealer and request any necessary repairs before your next outing.

### Stopping Diesel Engines

#### **WARNING**

**Do not use the engine stop switch and lanyard for normal stopping of the engines. Doing so will impair your ability to restart the engines quickly or may create a hazardous swamping condition.**

1. Slowly bring the throttle levers to the idle position.
2. Move the shift levers to neutral.
3. Move the throttle levers forward until engine speed is approximately 1400 RPM. Refer to propulsion unit operator's manual for cool down procedure.
4. After cooling the engines, move the throttle levers back to the idle position.

5. Turn the ignition keys to OFF position.



**NOTICE:** If any problems are encountered during the outing, have your boat inspected by your Cobalt dealer and request any necessary repairs before your next outing.

## Leaving

Use caution when casting off. Wind, water conditions and other boat traffic will affect your boat's movement. Move slowly and:

- Be sure the engines are warmed-up before casting off.
- Have enough space between the boat and the dock to allow you to swing the boat's bow away from the dock. The boat's stern will move toward the dock as the bow moves away. Allow for enough room or the stern will hit the dock.
- Retrieve all mooring lines and fenders.

- Proceed slowly. Sound a long blast to alert other boaters that you are departing.

When leaving a mooring, you should already have enough space around the boat to maneuver. Untie from the mooring and move back slowly until you can see it. Proceed slowly while giving the buoy wide clearance.

## Returning

### **WARNING**

**Do not use your hands, arms or another part of your body to attempt to keep the boat from hitting the dock. The boat could push against the dock, causing severe injury.**

Approach a dock slowly and use caution. Plan your maneuvers ahead of time. Allow wind and current movement to help maneuver your boat. Be sure to read **Basic Maneuvering** in this section.

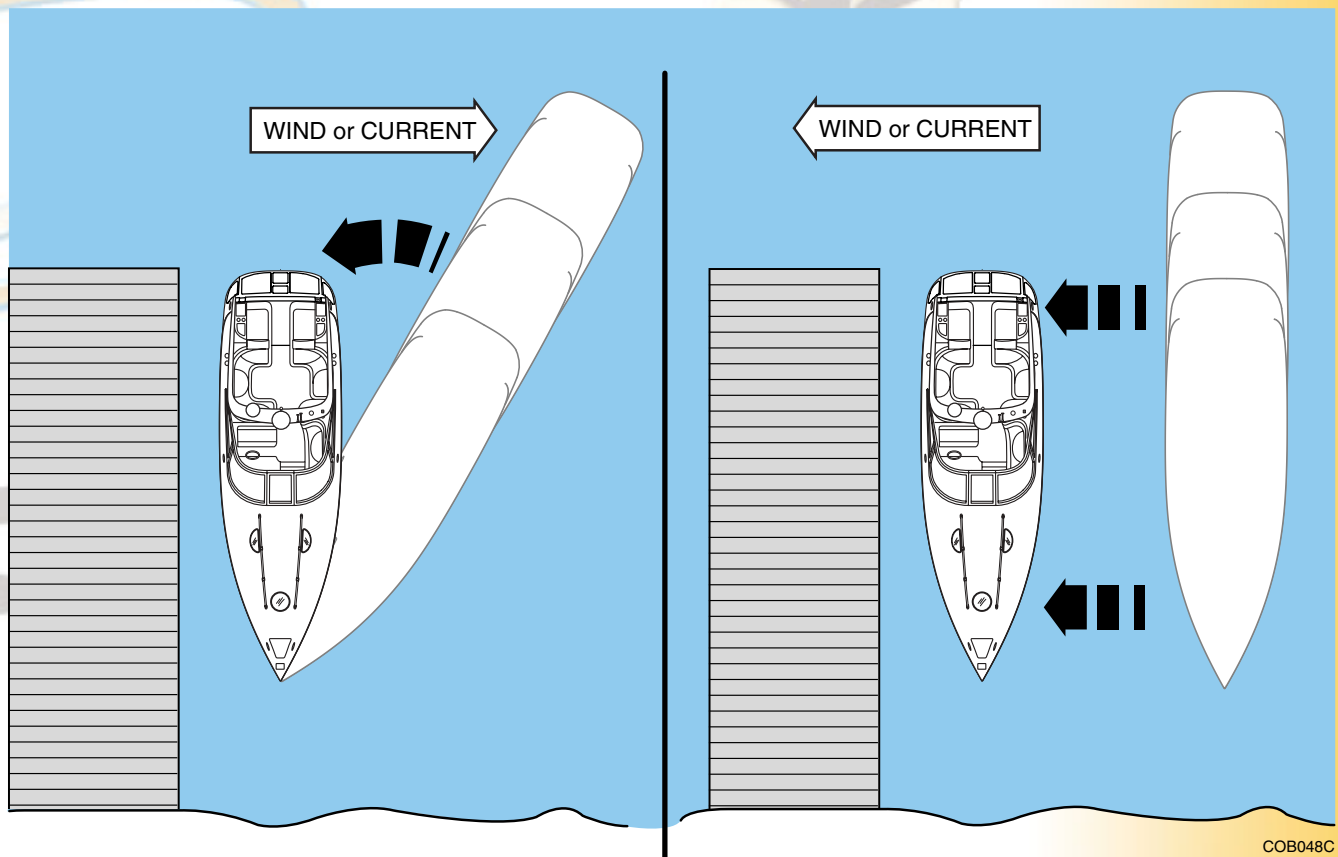

COB048C

## Docking

Follow these guidelines when docking:

- Come to a stop a short distance from the dock, then proceed slowly.
- Have your fenders, mooring lines and the crew ready.
- Observe how the wind and current are moving your boat. Approach the dock with the boat pointed into the wind, if possible. If the wind or current is pushing you away from the dock, use a sharper angle of approach. If you must approach the dock downwind or down current, use a slow speed and shallow angle. Be ready to reverse to stop and maintain position.
- If there is no wind or current, approach the dock at a 10° to 20° angle.
- If possible, throw a line to a person on the dock and have that person secure a bow line. If no one is on the dock, maneuver as close as you can, then secure any line to a piling or dock cleat.
- With the bow secure, swing the stern in using engine thrust, or pull it in with a boat hook.

## Approaching a Slip

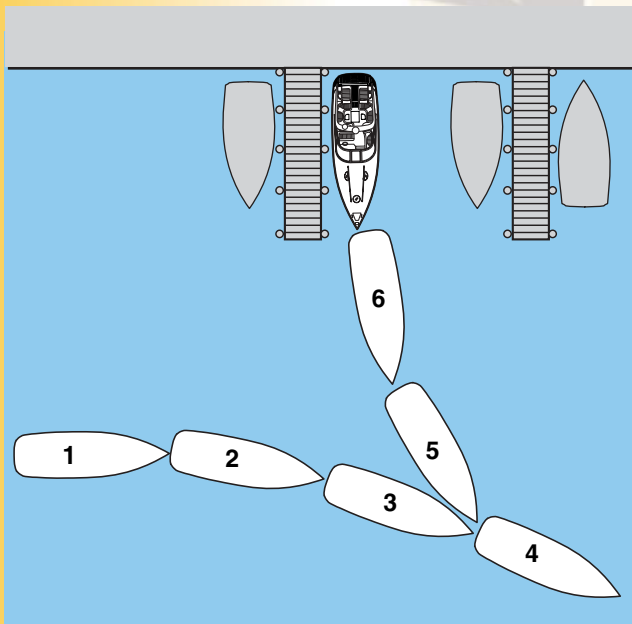

COB049C

This maneuver is similar to backing an automobile into a garage or parking space. When approaching a slip:

- Have fenders, mooring lines and the crew ready.
- Turn the boat's stern toward the slip.
- Shift to reverse.
- Maneuver slowly into the slip then shift to forward. Use your steering wheel and throttles to align the boat with the slip.
- Once aligned, shift to reverse and continue to back in slowly. Shift to forward when completely in to stop the movement of the boat.
- Shift to neutral, secure the mooring lines and stop the engines.

## Approaching a Mooring



COB050C

### 1. Mooring Buoy

The only buoys you are permitted to moor to are mooring buoys. Mooring to a navigation buoy or other navigational aids or regulatory marker is illegal.

Approach a mooring buoy by heading into the wind or current. Observe the direction of other boats that already lie at mooring buoys. Since they are heading into the wind or current, approach your buoy at the same heading.

- When you think you can move enough forward without using your engines, shift to neutral.
- Have a crew member positioned on the bow with a hook to retrieve the mooring line. At that point, the crew member should be guiding your maneuvers toward the buoy.
- Turn off the engines after the mooring line is attached to the boat.

## Basic Maneuvering

### Techniques

Wandering is a characteristic of all deep vee hulls at slow speed. There is no cure for wandering, however, a very basic operational technique can be applied which will minimize this characteristic. If the steering wheel is moved back and forth to compensate for wandering, invariably, the situation will be magnified. If the steering wheel remains in a centered position, the boat will wander back and forth slightly, however, the overall course of the boat will be a straight one.

### Trim

For trim switch identification, refer to **Shift/Throttle Control Panel**, in this section. Boat trim while on plane is influenced by three factors:

1. Load distribution
2. Drive unit trim
3. Trim tab position

Determining best boat trim while underway takes time. It is best to experiment with different drive and tab trim combinations while taking note of the condition.

## Load Distribution

The performance of your Cobalt 360 boat depends on load weight and distribution. Distribute weight evenly, from bow to stern, and also from port to starboard.

## Drive Unit Trim

Trim angle is the angular relationship between the drive unit and the transom of the boat. Boat trim while underway greatly affects the performance and efficiency of your boat. For best results, the boat should be on plane and trimmed to reduce the amount of the boat's hull in the water (known as wetted surface). With less boat in the water, both speed and fuel economy increases. Continuous trim adjustment is required when operating your boat to maintain maximum performance and efficiency.

If the drive units are trimmed in too far (closer to the boat bottom), speed drops, fuel economy decreases and the boat may not handle correctly. However, it does provide better acceleration from a stand still; and because it forces the bow down, visibility is improved. If the drive units are trimmed out too far (away from the boat bottom), steering torque may increase, the boat may be difficult to get on plane, and may bounce.

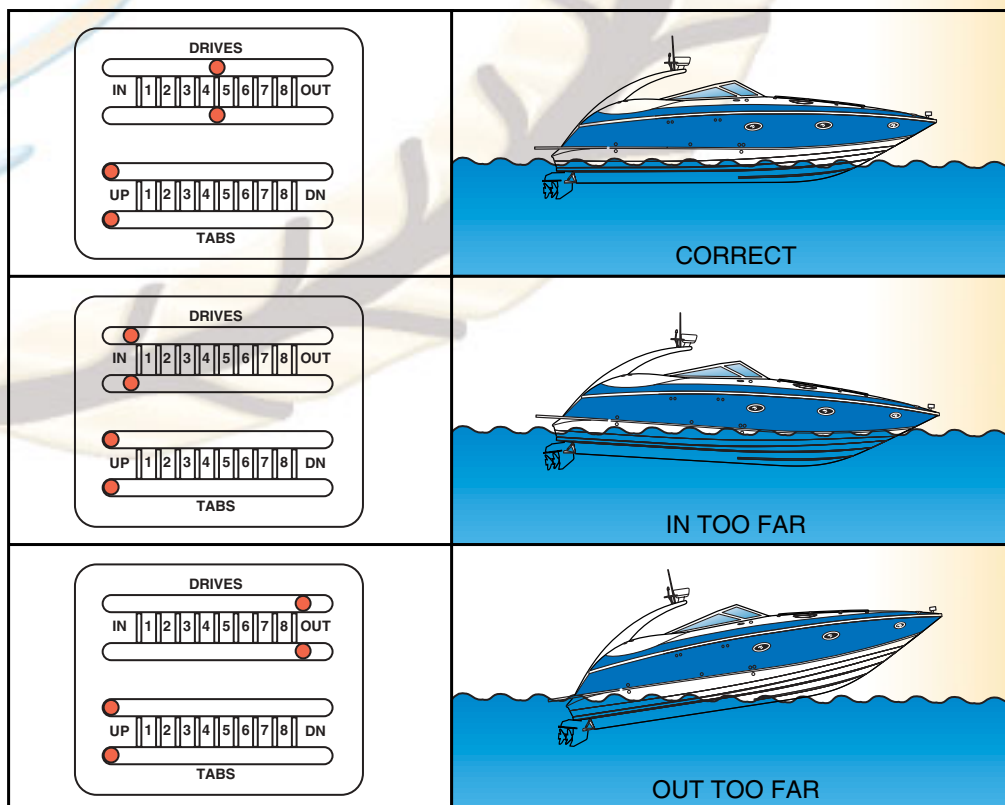

COB051C

To use power trim effectively, start with the drive units trimmed in. As the boat planes, increase the angle out. Experience is the best teacher for understanding proper drive trim.

**Trim Tabs**

The trim tabs are a separate system in themselves and are not to be used in lieu of the drive unit power trim system. Water is deflected and redirected as the trim tabs are raised and lowered. This change in the water flow creates upward pressure under the tabs, and raises the stern. When the stern raises, the bow is lowered. Likewise, lowering the port tab will cause the port stern to raise, making the starboard bow lower.

Using trim tabs in conjunction with the drive trim will compensate for uneven weight distribution, listing, water conditions and other factors that cause inefficient operation. Remember that trim tabs are trimming the hull while power trim is trimming the drive unit.

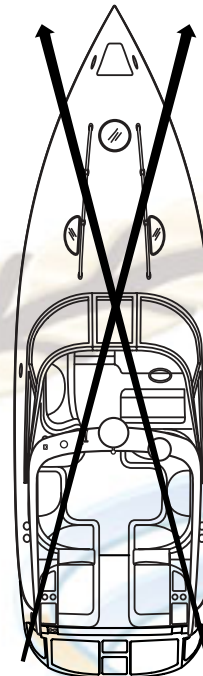

- PORT TAB LOWERED**
  - PORT STERN RISES
  - STARBOARD BOW LOWERS
- STARBOARD TAB LOWERED**
  - STARBOARD STERN RISES
  - PORT BOW LOWERS

COB052

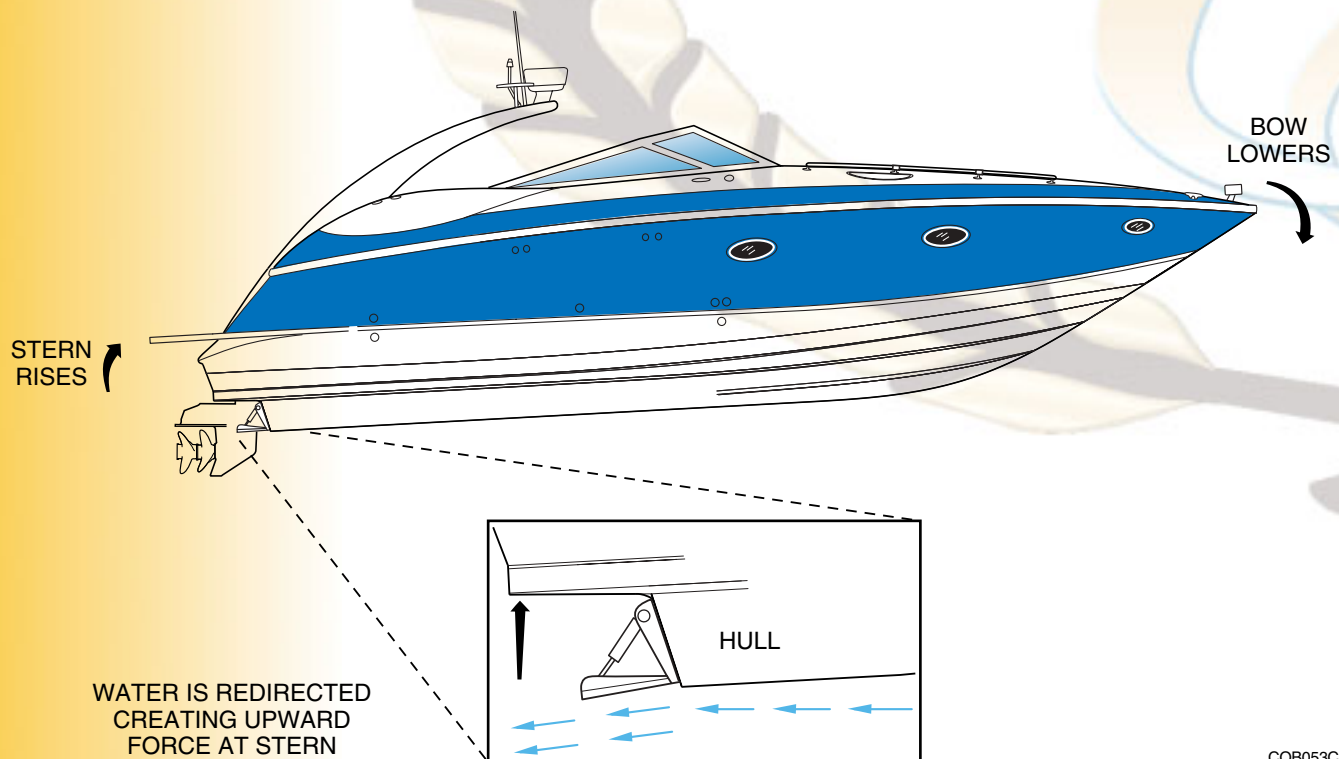

COB053C

# Operating Information

To adjust boat trim while underway:

1. Before accelerating, make sure both trim tabs are fully raised.
2. Adjust the trim tabs to achieve a planing attitude.
3. Use the drive trim to position the propeller path parallel to the water flow.

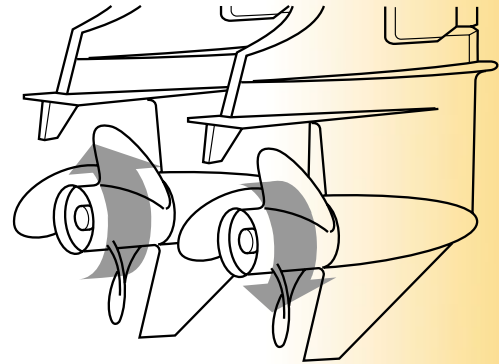

KC-2340

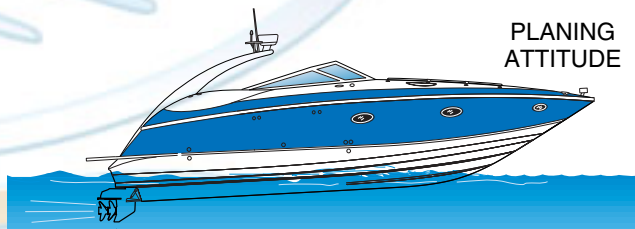
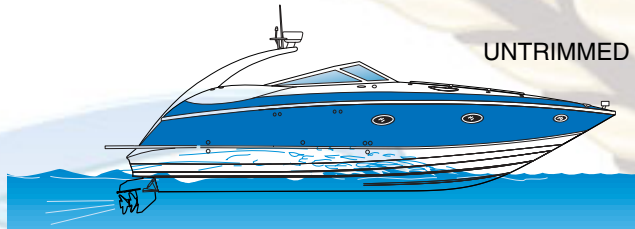

PROP PARALLEL TO WATER FLOW

COB054C

4. Readjust the trim tabs to fine tune attitude. Operate only one tab at a time and in small increments. As the tab takes effect, you will notice it causes the boat to veer off course slightly. Correct for this as it happens.
5. To prevent the boat from listing, do not move one tab significantly further down than the other tab.

## WARNING

Improper use of the trim tabs at high speeds can cause an accident or injury.

## Twin Engine Operation

Your Cobalt 360 Performance Cruiser has counter-rotating propulsion units. One unit will turn clockwise and the other unit will turn counterclockwise when operating. This concept balances the propeller torque which helps maintain an even keel.

Reverse thrust of the engines is used to slow and stop the boat. The boat's momentum will vary according to load, speed and water condition. Slow the engine speed to an idle, shift to neutral and pause, before shifting to reverse. Refer to your propulsion unit operator's manual for additional information concerning shifting.

When operating your Cobalt boat at low speeds, use propeller thrust to maneuver the boat, do not just turn the drive units. This enables you to maneuver in a smaller area and have more control of the boat. This technique is a combination of propeller direction, engine thrust and steering wheel maneuvers.

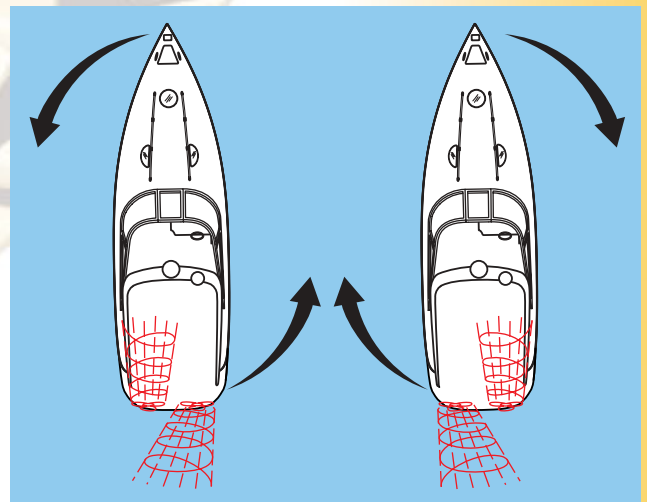

COB043C

To make sharp and close quarter turns:

- Slow engine speed to an idle, shift to neutral and pause, then shift to reverse. This practice will help prevent damage to your drive units.

- Reverse the direction of the propeller on the side you want to turn. For example, if you want to turn starboard, shift the starboard engine into reverse. The forward speed of the port engine, along with the reverse rotation of the starboard propeller, will pivot your boat into a starboard turn.
- Practice using the throttle levers to control the boat. Try maneuvers in open water before attempting them near docks or other boats.
- Use a quick “burst” of your throttles to control the boat. Keep in mind that once the boat starts to move, momentum will carry through.

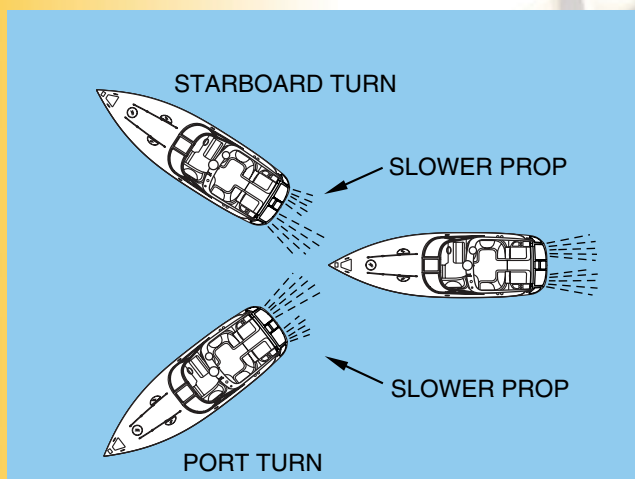

COB044C

It is best to learn maneuvering skills in open water away from traffic. Adequate practice is the only way to develop your boating skills.

## High Speed Operation

### ! WARNING

- Maneuverability above 50 MPH is limited. Sudden turns may cause loss of control.
- Your Cobalt boat is not designed for wake jumping. When crossing another boat's wake, throttle back to prevent your boat from leaving the water. Wake jumping is very dangerous. It is possible for the boat to re-enter the water on its side, transom or bow. You and your passengers could suffer serious injury. Also, damage to the boat could take place causing a hazardous condition.

When operating any boat at high speed, a great deal of caution must be exercised. This is particularly true during turns. Gradual turns can be completed at high speed by a competent driver, but, it must be emphasized that sudden turns at any speed and particularly at high speed can be especially dangerous. It is possible to throw passengers from their seats and even from the boat if caution is not exercised. Remember, common sense is the rule for safe boating.

We recommend that you should have ten hours of experience with the boat before any full throttle operation. Do not operate your boat until you are completely experienced with its handling characteristics. The following are some guidelines for performance operation.

- Keep bottom of the hull clean and free of barnacles and other growth. Growth on the hull can slow the boat down considerably.
- Prepare the boat. Be sure all gear is properly stowed and compartments are latched.
- Weight distribution affects performance. Keep weight in the boat to a minimum and evenly distributed.
- The propellers should be of the proper pitch to turn the recommended RPM rating for the engine with an average boat load. Refer to your propulsion unit operator's manual for additional information.
- Watch the tachometer. Keep the engines within the full throttle operating range. Refer to the propulsion unit operator's manual for full throttle operating range.

### ! WARNING

**Keep one hand on the steering wheel and the other on the throttle controls at all times. If the boat begins to operate in an unsafe way, pull back on the throttles. Trim the drive units IN at the same time. Failure to maintain control could result in severe injury or death.**

High-speed operation on smooth water is very stable, but quick reactions and adjustments are needed to maintain control. Know your limits and stay within them. Keep one hand on the steering

wheel and the other on the throttles; constant adjustments are necessary for rapidly changing conditions. Small inputs of throttle and steering movement are exaggerated at high speeds. Keep watch well ahead so that you have enough time to react.

## Anchoring

### **WARNING**

**Anchor from the bow, not from the stern. A strong current can pull a boat, anchored by the stern, underwater and keep it there.**

The windlass gets its power from the 12 VDC system. The windlass can be operated at the driver's helm (indicator light must be illuminated) or from the foredeck. There are foot operated switches located under the anchor locker door.

The windlass system can also be operated manually. On the anchor locker lid on the foredeck, you will find a crank. A longer windlass crank is located under the port cockpit seat cushion. Please consult the operator's manual supplied with the windlass system for proper operation of the system in the electric and manual modes.

The circuit breaker on the battery switch panel under the port aft seat must be in the ON position to operate the windlass. When not in use, turn the circuit breaker to the OFF position.



COB076

### **WARNING**

- **Keep hands, feet, loose clothing and hair well clear of the winch and rope/chain during operation.**
- **Be sure you have a clear view of the winch when operating it.**
- **Run the boat's engines while raising or lowering the anchor. Not only is this a safety precaution, it also prevents draining of the batteries.**
- **Do not use the winch as a bollard. When anchored, secure the anchor line directly to a bollard or deck cleat.**
- **Secure the anchor with a rope or fastener pin when operating the boat at high speed or in heavy weather.**
- **Turn the WINDLASS switch off when the winch is not in use and before leaving the boat.**
- **Keep the rope in good condition and free from twists, knots, heavy abrasions and salt buildup. In the event of the rope slipping or jamming, reverse the direction of the winch and check the rope for damage.**

Use caution when anchoring. Look for signs of underwater pipes or cables. With the engines off, you have no control of the boat. Water and wind conditions will affect an anchored boat. Be sure the anchor will hold before leaving the boat.

## Lowering

Bring the boat to a stop with the bow facing into the wind or current. Lower the anchor. On dash control, place starboard safety switch in the ON position (up). Press and hold the port toggle switch down to pay out sufficient rope/chain to set the anchor.

## Setting

When the anchor hits bottom, slowly back up the boat, keeping tension on the line. The anchor line should be five to seven times the depth of the water.

## Weighing

To weigh (retrieve) the anchor, start the engines and slowly move forward. Press the toggle switch up while taking in anchor line as you go. Carefully retrieve the last meter (36 inches) of rope/chain, then seat the anchor in the bow fitting. Use snubber to secure the anchor at all times in case of windlass clutch failure.

Refer to the windlass operator's instructions for additional operating information.

## Towing

If seas are rough, it may not be easy to extend the tow line from one boat to another. In these cases, use a light throwing line with a weight on one end and with the heavier towing line secured to it.

Do not attempt to tow a larger or grounded vessel. Because of the tremendous stress caused by towing, use a tow line that is rated at least four times the gross weight of the boat being towed. Tow ropes must be in good condition, free of any cuts or abrasions.

Attach the tow line to the bow eye on the disabled boat. Attach the opposite end of the bridle only to the stern cleats of the tow boat. Wrap the bridle with chafing gear where it rubs against the boat. Leave at least two boat lengths between the boats for adequate movement.



## WARNING

**When towing, use only the bow eye and stern cleats; do not use deck cleats, handrails, etc. Do not allow anyone to be in line with the tow rope. If the rope should break or pull free, a dangerous recoil could occur resulting in severe injury or death to anyone in its path.**

Adjust the tow line to match wave action. Keep the boats on the crest or in the trough of the waves at the same time. In protected, calm waters, shorten the line for better handling. Tow at moderate speed, allowing for adverse wind and wave conditions. Have the operator of the towed boat steer with you, if possible.

If you need a tow, or wish to tow another boat, use great care. The boat structure can be damaged by excessive pulling strain. You should offer help to a boat in trouble. However, towing a capsized, grounded or hull damaged boat is dangerous. Give assistance to the occupants; then call the proper authorities.

## Environmental Considerations

Using your boat in different environments requires special operating considerations.

## Salt Water

During long periods of mooring, if possible, tilt the propulsion unit drives out of the water – except in freezing temperatures.

Fresh water flushing of the engines is recommended after operating in salt, polluted or brackish water. Refer to your engine operator's manual for additional information.

## Freezing Temperatures

When boating in temperatures below freezing, keep the propulsion unit drives tilted down (submerged) at all times. This will prevent damage from freezing.

Upon removing your Cobalt 360 Performance Cruiser from the water, leave the drive units in the vertical position until cooling system has drained. Refer to your propulsion unit operator's manual for additional information regarding winterization.

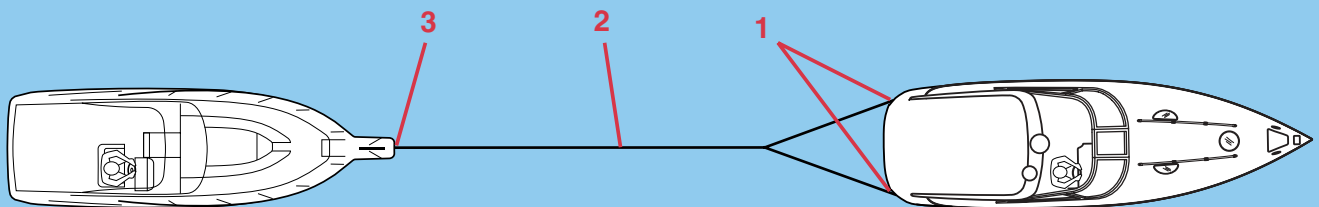

1. Stern Cleats
2. Tow Line
3. Bow Eye

COB028C

Use caution when handling clear vinyl canvas in low temperatures to prevent damage from cracking.

## Canvas, Curtains and Covers

Cobalt uses Sunbrella® woven fabric. Even though it is treated with a water repellency, some “misting” through the fabric is typical.

With new canvas, the greatest potential for leakage is through the sewn seams. Because Sunbrella and the long-term thread used are synthetic, the holes created by sewing will not swell up and seal when exposed to water as cotton does. Usually, the movement of the fabric in use will shift the fibers enough to seal the holes. You may apply a few light coats of “303 HIGH TECH FABRIC GUARD” to speed up the process.

When the canvas is new, the fit will normally be tight. It is designed this way because Sunbrella stretches as it ages. The initial tight fit allows for a suitable fit for the life of the canvas.

The fit with Sunbrella will vary slightly in the heat, cold and rain.

It is very important the proper canvas is used as designed. The canvas listed in items 1 and 2 below is made of Sunbrella, an acrylic material. Acrylic does not breathe as well as polyester, therefore all moisture cannot escape the boat when covered. The mooring cover listed in item 3 is made of 100% Sharkskin™ polyester.

### 1. Bimini Top and Enclosure

- Used for day or night boating
- Not designed for storage use

### 2. Cockpit Tonneau

- Trailering
- Overnight protection
- Not designed for storage use

### 3. Mooring Cover

- Storage – short or long term

## Arch Bimini and Enclosure

The Arch canvas consists of three parts: the forward bimini top which covers the helm; the aft bimini top which covers the cockpit; and the enclosure which encloses the entire cockpit area. The enclosure vinyl curtains are stowed in the mid cabin or under the cockpit seats. When stowing the curtains, always roll the vinyl and use care to prevent scratches. Do not use the arch canvas cover for storage any longer than a few days; use the optional mooring cover for extended storage.

## CAUTION

**Do not exceed 40 MPH when using the bimini(s) and/or enclosure. Be aware of strong head winds and adjust speed accordingly.**



COB137

To use the forward bimini:

1. Unzip boot from arch.
2. Remove two pins from the bottom side of the arch, reposition bows to brackets on windshield and install pins.
3. Unzip boot and unroll canvas from bows.
4. Zip canvas to zipper on top forward area of arch and snap.
5. Install forward straps or forward arms (located under aft port bench seat) by inserting pins on top and pressing into the quick release receptacle on the deck at bottom below navigation light. Turn knurled twist grip on top of the arm to adjust tension. **DO NOT OVERTIGHTEN.**

To remove the forward arms, release tension and press slide button on quick release receptacle aft. Reverse procedure to stow canvas.



COB138

To use the aft bimini:

1. Unzip boot from the arch.
2. Unroll canvas and zip back to the arch zipper.
3. Rotate bow aft and attach straps to eyelets on arch. Tighten straps as necessary.



COB139

To install the enclosure:

1. Set up forward and aft bimini tops.
2. Zip canvas to the biminis and snap to windshield and deck. Start at the center and continue aft along each side.

When stowing, roll enclosure canvas – do not fold the clear vinyl.

### Cockpit Tonneau Cover – Optional



COB140

The cockpit tonneau cover protects the helm and cockpit from damage due to birds, UV light and weather, and is highly recommended to protect your investment. Do not use the tonneau cover for storage any longer than a few days, use the optional mooring cover. To install the tonneau cover:

1. Unroll cover and snap to the deck by starting at the center of the windshield.
2. Install the tonneau support poles to the underside of cover with snap and adjust poles to approximate height of windshield. Poles are stored under the starboard cockpit bench seat.
3. Snap the aft end of the cover to back deck starting in center and working outboard.



**NOTICE: You may have to readjust the support poles for proper fit.**

4. Continue snapping up sides.

## Mooring Cover – Optional



COB141

A mooring cover is recommended for any storage longer than a few days. Cobalt mooring covers are made from 100% SharkSkin polyester that will properly protect the gelcoat finish on the deck of your Cobalt. Mooring covers are not recommended for trailering because they cannot be tied down tightly enough to keep them from moving on the gelcoated fiberglass surface. This movement can damage the gelcoat causing dullness or even scratching.



**NOTICE:** For long term storage, use the optional mooring cover made of 100% Sharkskin polyester, do not use the bimini, enclosures or tonneau cover for storage longer than a few days. These tops were not designed with enough ventilation for long-term storage and mold/mildew may form. For more information on appropriate covering for long term storage, consult your Cobalt dealer.



Your Cobalt 360 Performance Cruiser is equipped with a variety of major systems to operate the craft and provide the conveniences you expect while on the water. This section describes the basic operational principles of these systems.

## MACHINERY ARRANGEMENT

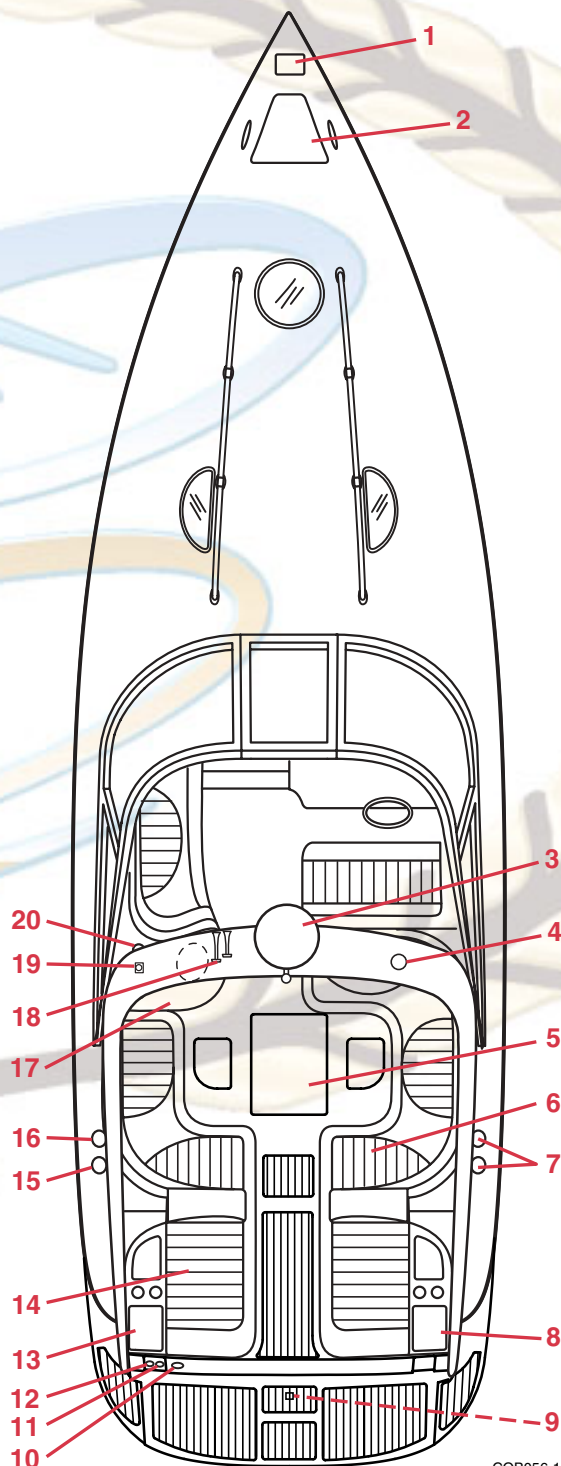

COB056-1

### **WARNING**

Regularly inspect and maintain all systems to prevent unexpected hazards associated with worn or faulty components. When replacement parts are required, use marine grade parts with equivalent characteristics, including type, strength and material. Using substandard parts could result in injury and product failure.

1. Optional Search Light
2. Windlass
3. Optional Radar Scanner
4. Optional GPS Antenna
5. Cockpit Table Stowage/Generator
6. Engine Hatch Manual Handle Stowage
7. Fuel Tank Fill Caps
8. Optional Starboard Speaker
9. Drain Plug
10. Cable TV/Phone Jack
11. Shore Plug 2
12. Shore Plug 1
13. Optional Port Speaker
14. Air Pump
15. Fresh Water Fill Cap
16. Waste Water Cap
17. Icemaker
18. Horns
19. Optional Radio Antenna
20. Cockpit Sink

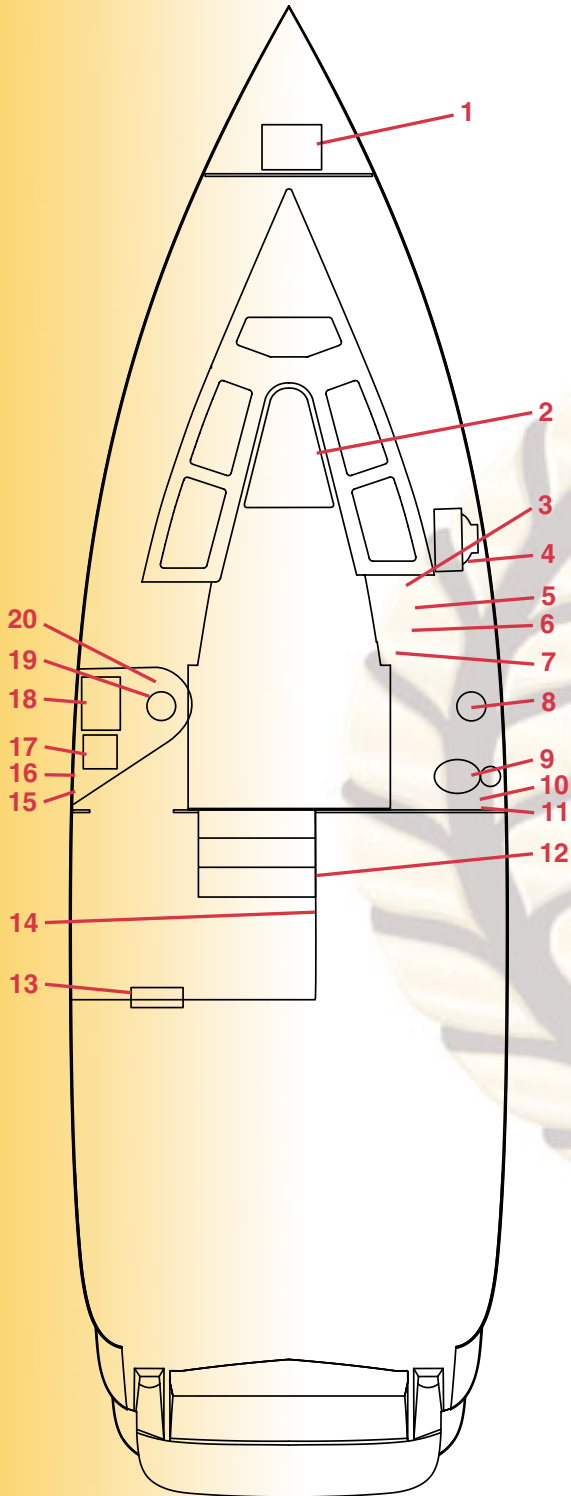

COB086

1. Air Conditioning Unit
2. Cabin Table
3. CD Changer
4. Cabin TV
5. Cabin CO Detector
6. Entertainment Center
7. Air Conditioning Controls
8. Bath Sink
9. Head
10. Fresh Water Level Indicator
11. Waste Tank Level Indicator
12. Cabin Light Switch
13. Optional Midberth TV
14. Midberth CO Detector
15. Optional Shore/Generator Switch
16. Cabin Distribution Panel
17. Stove
18. Microwave
19. Cabin Sink
20. Refrigerator/Freezer

**DIMENSIONS**

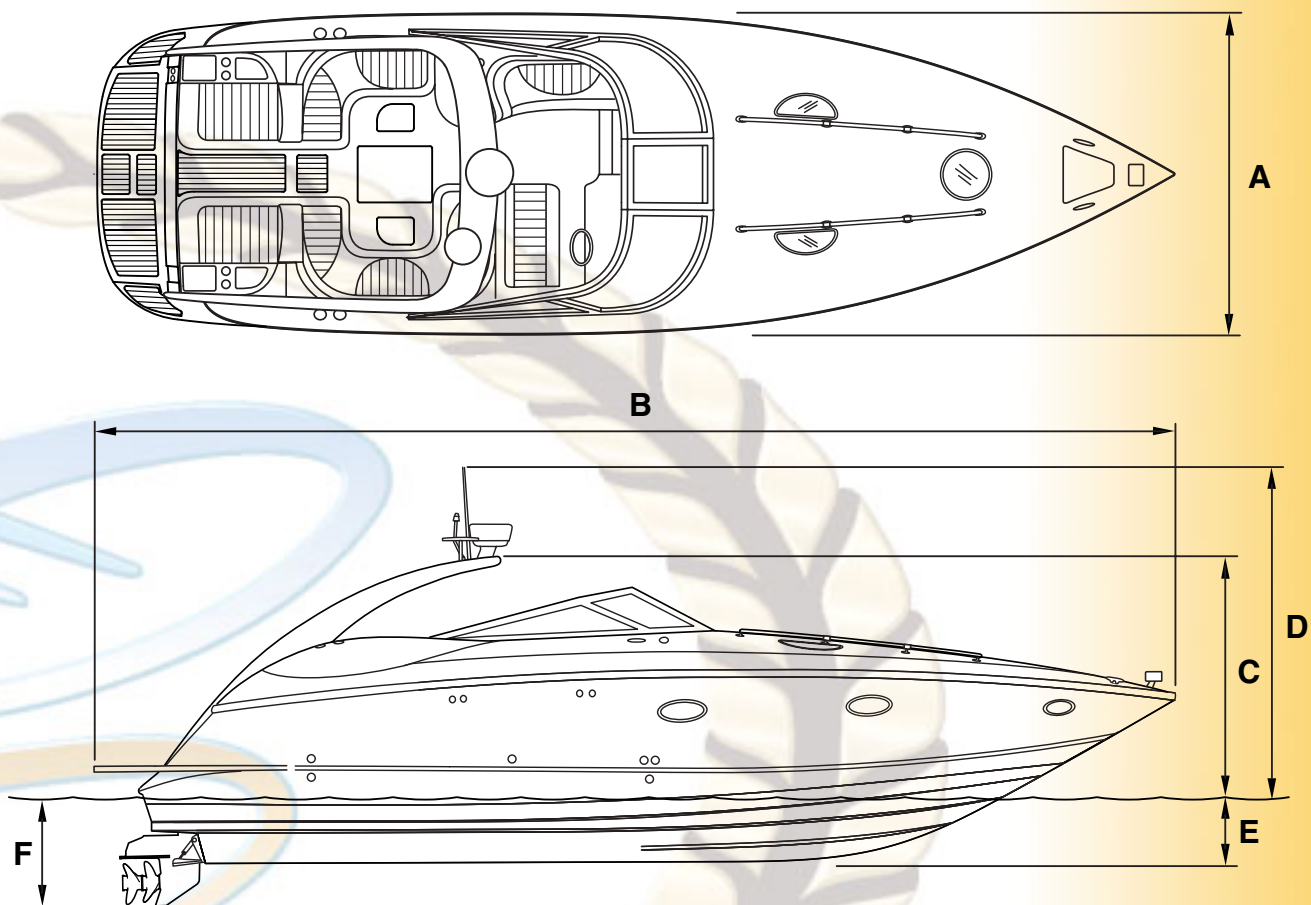

COB087

A	Beam	10' 6" (3.20 m)
B	Length Overall	36' 0" (11 m)
C	Bridge Clearance w/o Radar	8' 5" (2.46 m)
D	Bridge Clearance w/Radar	9' 6" (3.15 m)
E	Draft, Drive Up	27" (69 cm)
F	Draft, Drive Down	42" (107 cm)

## DOORS, HATCHES AND STOWAGE

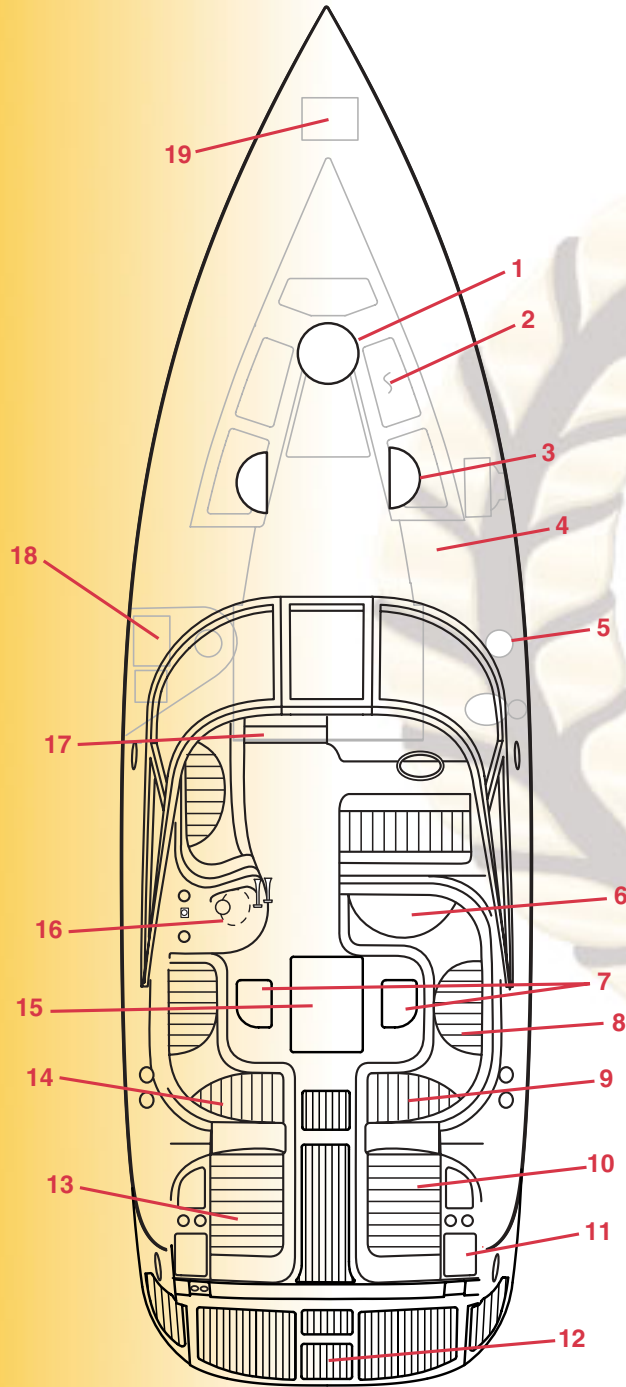

COB098

1. Deck Hatch
2. Cabin Underseat Storage
3. Cabin Vents
4. A/V Cabinet Storage
5. Head Vanity Storage
6. Cockpit Underseat Storage
7. Fuel Tank Access
8. Cockpit Table Storage
9. Engine Compartment Handle Storage
10. STBD Lounge Underseat Storage
11. Aft Storage Locker
12. Ladder Hatch
13. Air Pump Storage
14. Battery Switch Compartment
15. Fuel Valve/Generator Compartment
16. Cockpit Icemaker Compartment
17. Cabin Door
18. Galley Cabinet
19. AC Access

### CAUTION

**Do not use a raised hatch for a support or hand hold while on the deck. Be sure hatch is firmly secured while underway.**

Make sure the head compartment door assembly is closed and latched while the boat is underway. Do not allow it to swing freely.

The deck hatches are operated manually. To open, simply release the one or two hasps on the edge of the hatch, make sure the support bracket adjusters are loose, and raise the hatch to the desired position and secure the adjusters.

## DECK PLATES/THRU-HULLS

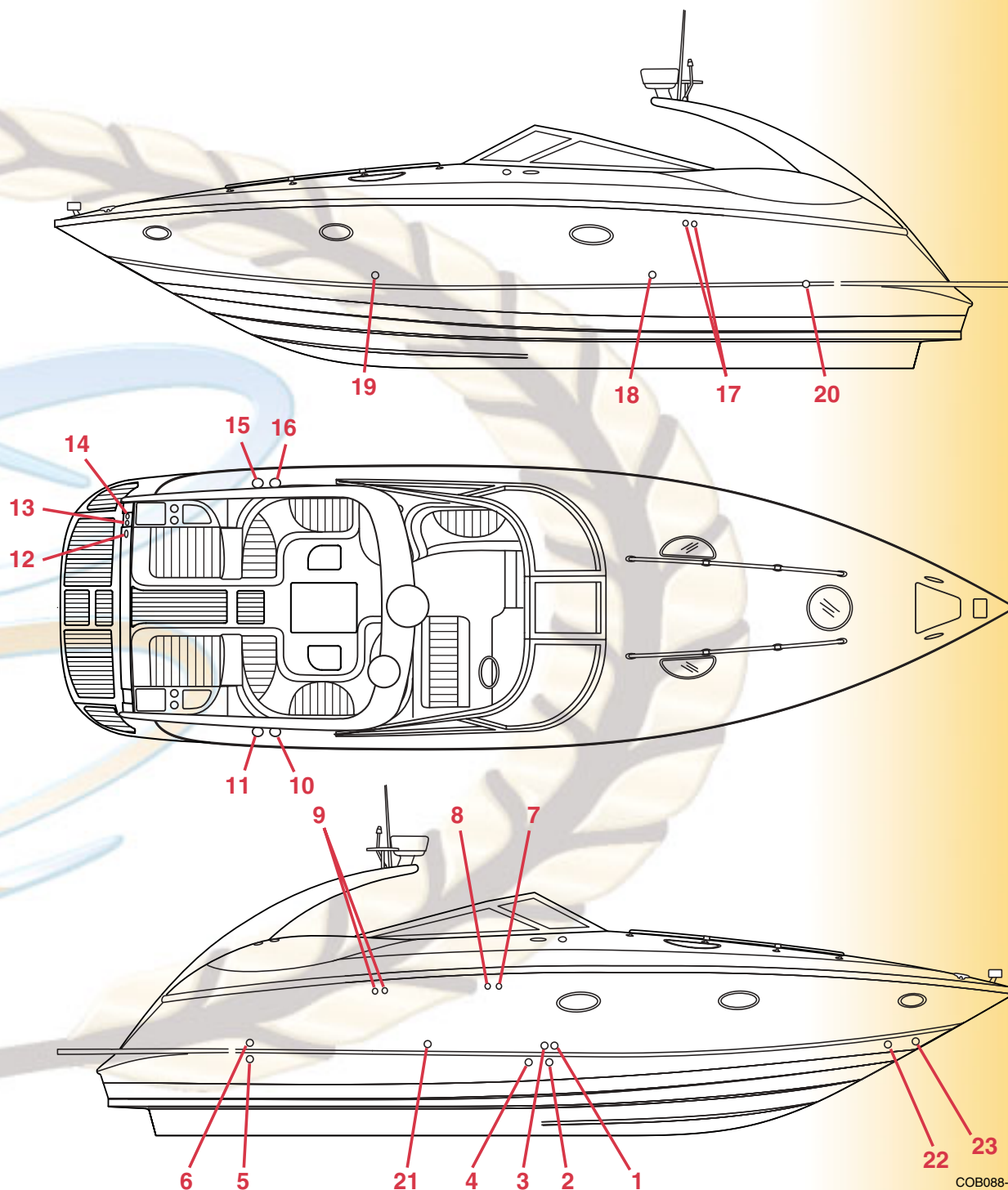

COB088-1

- |                                 |                              |                                    |
|---------------------------------|------------------------------|------------------------------------|
| 1. Shower Sump Pump             | 9. Starboard Fuel Tank Vents | 17. Port Fuel Tank Vents           |
| 2. Head Sink Drain              | 10. Starboard Fuel Tank Fill | 18. Cockpit Sink Drain             |
| 3. Forward Bilge Pump           | 11. Port Fuel Tank Fill      | 19. Cabin Galley Sink Drain        |
| 4. Cabin Door Track Drain       | 12. Cable TV/Phone Jack      | 20. Cockpit Overboard Drain        |
| 5. Generator Exhaust (Optional) | 13. Shore Power 2            | 21. Macerator Discharge (Optional) |
| 6. Aft Bilge Pump               | 14. Shore Power 1            | 22. Air Conditioning Discharge     |
| 7. Water Vent                   | 15. Water Fill Deck Plate    | 23. Anchor Locker Drain            |
| 8. Waste Vent                   | 16. Waste Deck Plate         |                                    |

## DECK OCCUPANCY

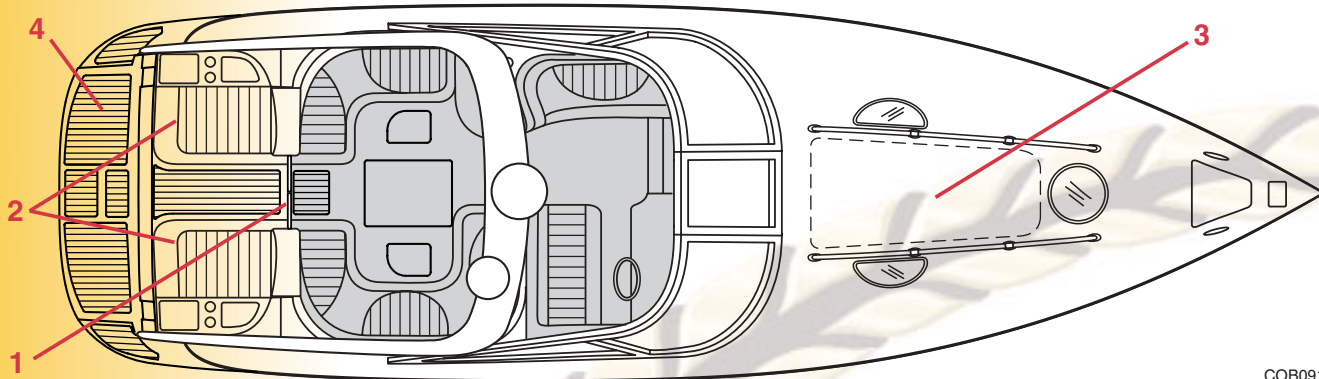

COB091

- 1. Cockpit Door
- 2. Stern Sundeck Pads
- 3. Bow Sun Pad
- 4. Swim Platform

### WARNING

Do not allow passengers to sit in the two stern sundeck pads or on the bow sun pad, or stand on the swim platform when the boat is underway.

Be sure the cockpit door is in the closed and locked position anytime the boat is underway.

## BILGE

- 1. Forward Bilge Pump
- 2. Generator Muffler
- 3. Air Conditioning Strainer
- 4. Air Conditioning Pump
- 5. Air Conditioning Seacock
- 6. Starboard Engine Battery
- 7. Starboard Trim Tab Pump
- 8. Starboard Drive Unit Pump
- 9. Starboard Engine
- 10. Aft Bilge Pump
- 11. Port Engine
- 12. Port Drive Unit Pump
- 13. Port Trim Tab Pump
- 14. Port Engine Battery
- 15. Generator Battery
- 16. Generator Seacock
- 17. Generator Strainer
- 18. Battery Charger
- 19. Transformers
- 20. Port Engine Battery Switch
- 21. Generator Battery Switch
- 22. Starboard Engine Battery Switch
- 23. Windlass Circuit Breaker
- 24. Battery Jump Terminals

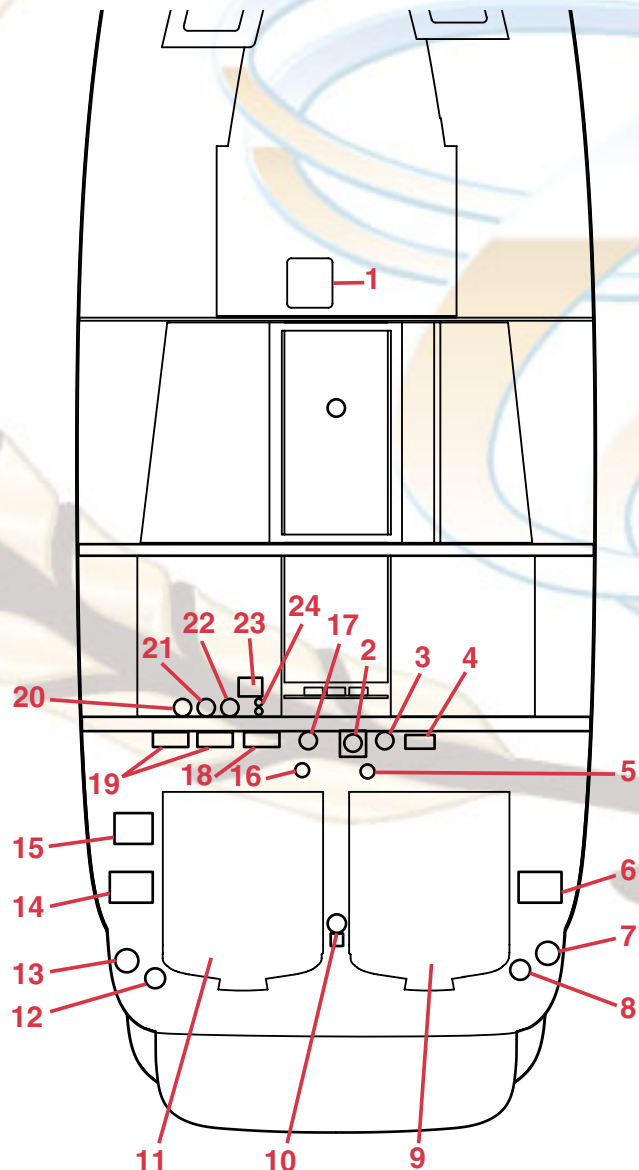

COB090

## FUEL

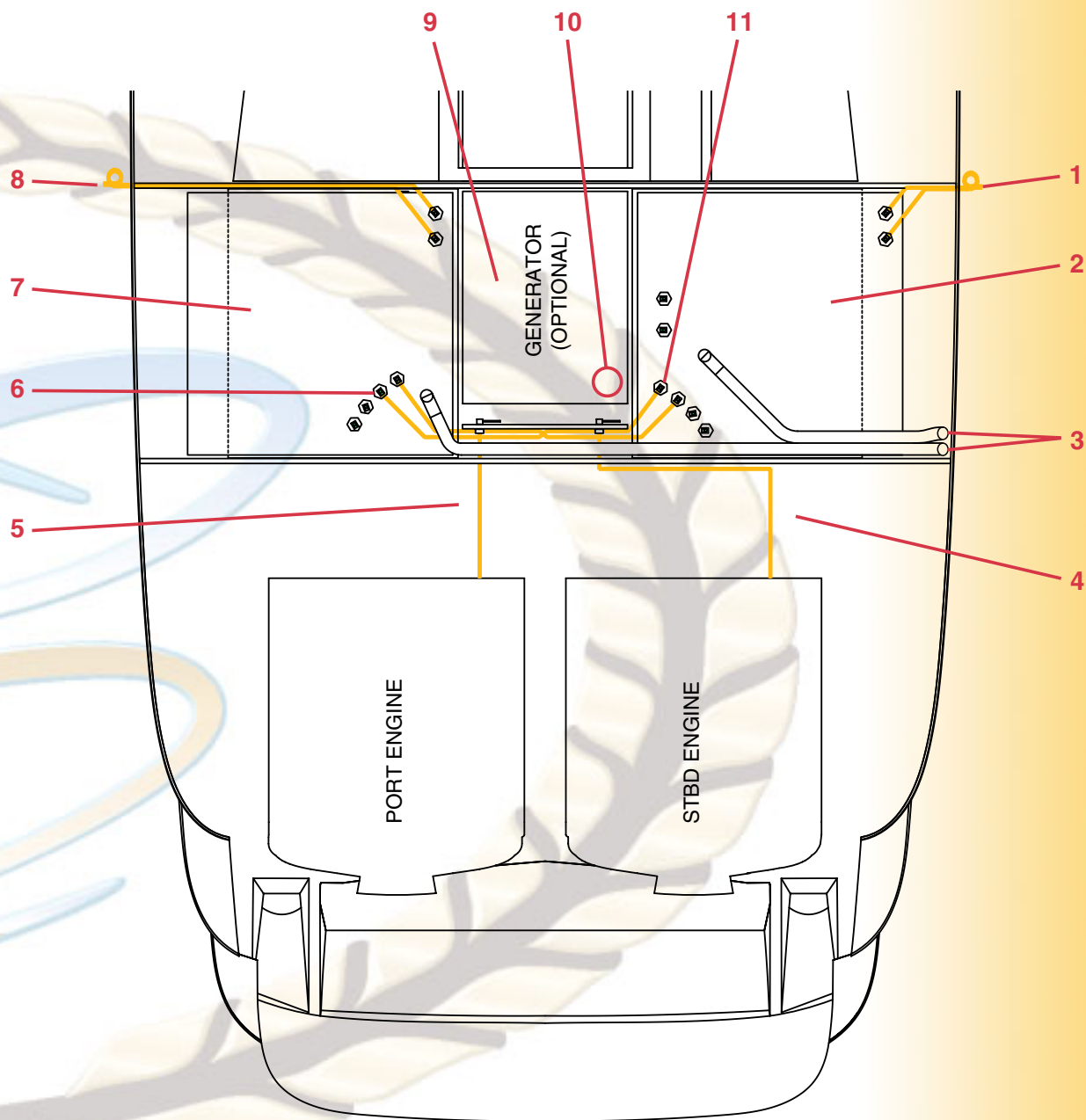

COB061

- |                               |                                    |
|-------------------------------|------------------------------------|
| 1. Starboard Fuel Tank Vents  | 7. Port Fuel Tank                  |
| 2. Starboard Fuel Tank        | 8. Port Fuel Tank Vents            |
| 3. Fuel Tank Fill Caps        | 9. Optional Generator              |
| 4. Starboard Engine Fuel Line | 10. Generator Fuel/Water Separator |
| 5. Port Engine Fuel Line      | 11. Starboard Fuel Tank Pickups    |
| 6. Port Fuel Tank Pickups     |                                    |

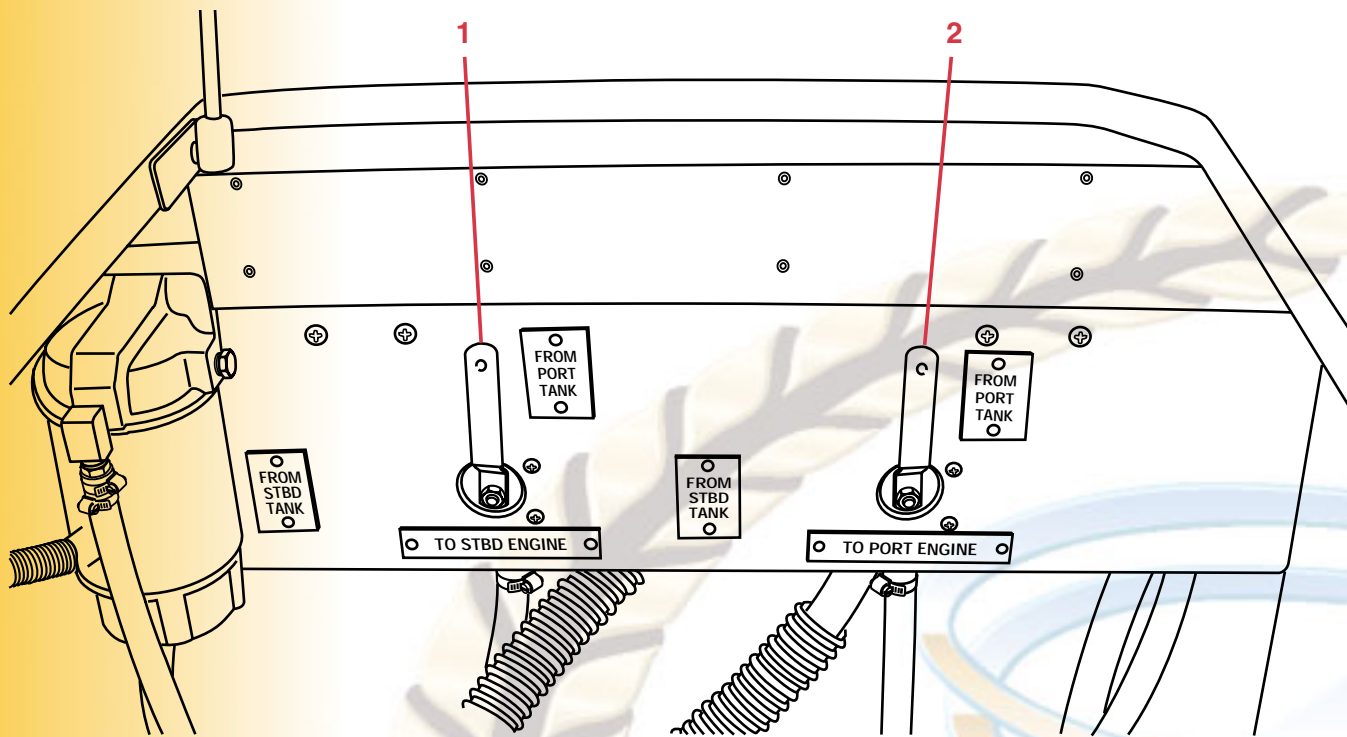

COB007

1. Starboard Engine Fuel Valve
2. Port Engine Fuel Valve

**! WARNING**

Your fuel system should be checked before each operation. At least once a year, have your fuel system thoroughly checked by a certified Cobalt service technician. Gasoline is highly flammable; extreme caution should be used at all times.



**NOTICE:** The generator uses fuel from the starboard tank, but will only operate when the tank is at least 1/4 full. This prevents the generator from emptying the fuel tank completely.

Refer to your propulsion unit operator's manual for additional fuel system information.

The line between the fuel tank and the fuel inlet of the engine is made of a synthetic, flexible material and although it is the best material available, alcohol can deteriorate it, especially during periods of storage. For this reason, it is suggested you have your Cobalt dealer inspect this fuel line at least annually and replace, if necessary.

Fuel valves located in the generator area under the cockpit floor control fuel flow to the main engines. Normal operation is starboard engine valve to starboard tank, port engine valve to port tank.

## MARINE TOILET

The marine toilet (head) uses water from your fresh water tank and pumps the waste water into a holding tank.

Your Cobalt boat is fitted with a waste holding tank that is emptied through the deck plate fitting marked WASTE. Waste is pumped from the head through a sanitary waste hose to the top portion of the tank. A 1-1/2" sanitary waste hose is attached to the bottom of the tank, and runs to the deck plate fitting marked "WASTE." An overboard vent keeps the tank at atmospheric pressure regardless of waste levels.

All the components which comprise the waste system are made of materials specially formulated to prevent odor permeation and to resist chemical actions. It is strongly recommended that you regularly add chemical to your waste tank by flushing it through the head. The chemical helps to control odor and break down the waste. Follow the manufacturer's instructions on the chemical before using.

## CAUTION

**Do not flush into a full holding tank. Attempting to flush the head when the tank is full could result in damage to the waste system.**

### VacuFlush®

Your Cobalt 360 Performance Cruiser is equipped with a VacuFlush Head System. In order to use toilet system, turn on the "MAIN", "HEAD", and "WATER PRESSURE" breakers at the cabin distribution panel. Turn on switch located behind the toilet, initially the red light will illuminate until a vacuum is generated in the tank (approximately one minute, must have small amount of water in bowl). The green light will come on when the system is ready to operate. Lift lever for extra water, if needed, and depress lever to flush. Overboard shutoff valve for optional macerator is accessed through cover below the helm seat. This must be open before using the macerator.

Flushing is controlled by pushing down on the pedal at the base of the toilet. Lifting up on the pedal will raise the water level in the bowl, if needed.

Vacuum energy is maintained in the system at all times. When the toilet is flushed, the vacuum energy stored in the system is released instantly clearing the bowl of waste.

Under normal operating conditions, the red lamp will light after each flush until the pump recharges the vacuum to proper operating level then the green lamp will light.

If there is constant green light or red light cycling between flushes, it may indicate a leak in the vacuum system. The vacuum pump will normally operate automatically every so often to recharge the vacuum.

### VacuFlush Status Panel



COB123

#### 1. VacuFlush Status Panel

A continuous red light indicates an extended loss in vacuum as a result of a blockage, pump failure or massive vacuum leak. Turn off the system and have your Cobalt dealer repair the system as soon as possible. Please refer to the VacuFlush manual for further information.

### Macerator Discharge Pump (Optional)

## CAUTION

**Overboard discharge of waste water should only be used in approved areas. It is your responsibility to comply with local regulations regarding the discharge of waste. You could be fined if your boat has an operable overboard discharge system. Removing the handle of the seacock while in closed position, or disabling the system by other means may be required to avoid a fine.**

The optional macerator system allows the discharging of waste water directly overboard through a seacock. The seacock's valve located under helm access cover must be opened to allow activation of the macerator pump switch located in the head area. For additional operating information, refer to the macerator operator's manual supplied with your Cobalt boat.

# PIPING

## Fresh Water

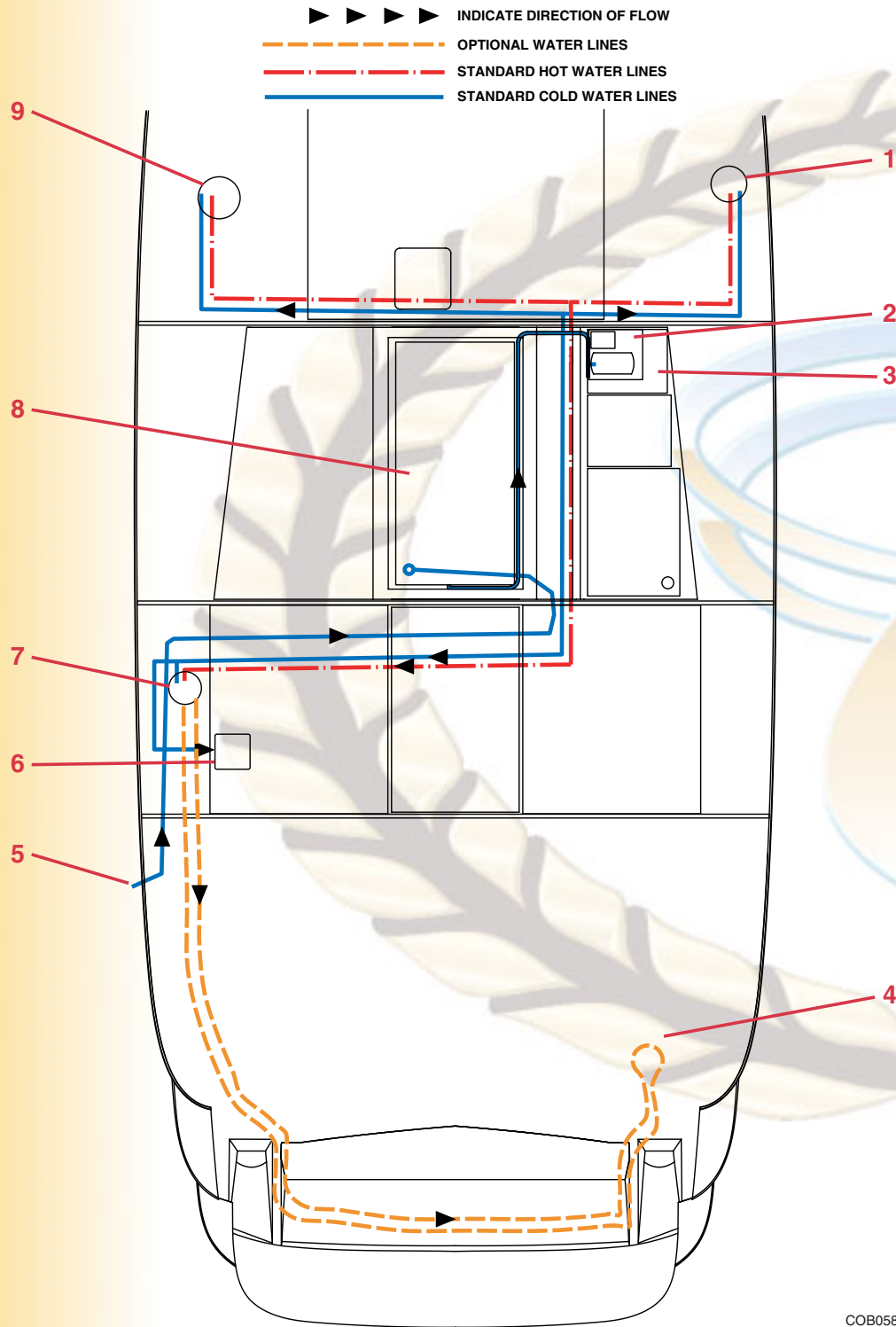

COB058

- |                            |                               |
|----------------------------|-------------------------------|
| 1. Head Sink               | 6. Icemaker                   |
| 2. Water Pressure Pump     | 7. Cockpit Sink               |
| 3. Water Heater            | 8. 35-Gallon Fresh Water Tank |
| 4. Optional Transom Shower | 9. Galley Sink                |
| 5. Water Fill Cap          |                               |

The fresh water system provides potable (drinkable) water to the sinks, showers, hot water heater, icemaker and cockpit washdowns.

Your Cobalt Performance Cruiser is equipped with a 35-gallon capacity water system. The system is operated by a 12 VDC water pump located under the helm station. It is necessary for the 12 VDC system to be energized and the WATER PRESSURE switch to be turned on to operate the water system. Consult your Cobalt dealer for winterization requirements.

The fresh water level indicator display panel shows the level of the water in the 35 gallon water tank as follows:

Red Light.....Empty  
Amber Light.....Mid  
Green and Amber Light.....Full



**NOTICE: No indication is given if the tank is 1/8 to 1/2 (mid) full.**

The water pump works on demand. It will not automatically shut off when the fresh water tank is empty. Monitor the level of water in the tank. If the water pump is allowed to run continuously, it may overheat.



COB117

1. Fresh Water Level Indicator
2. Gray Water Level Indicator
3. Waste Water Level Indicator

## Grey Water (Optional) - Sink and Shower Drain Water Only

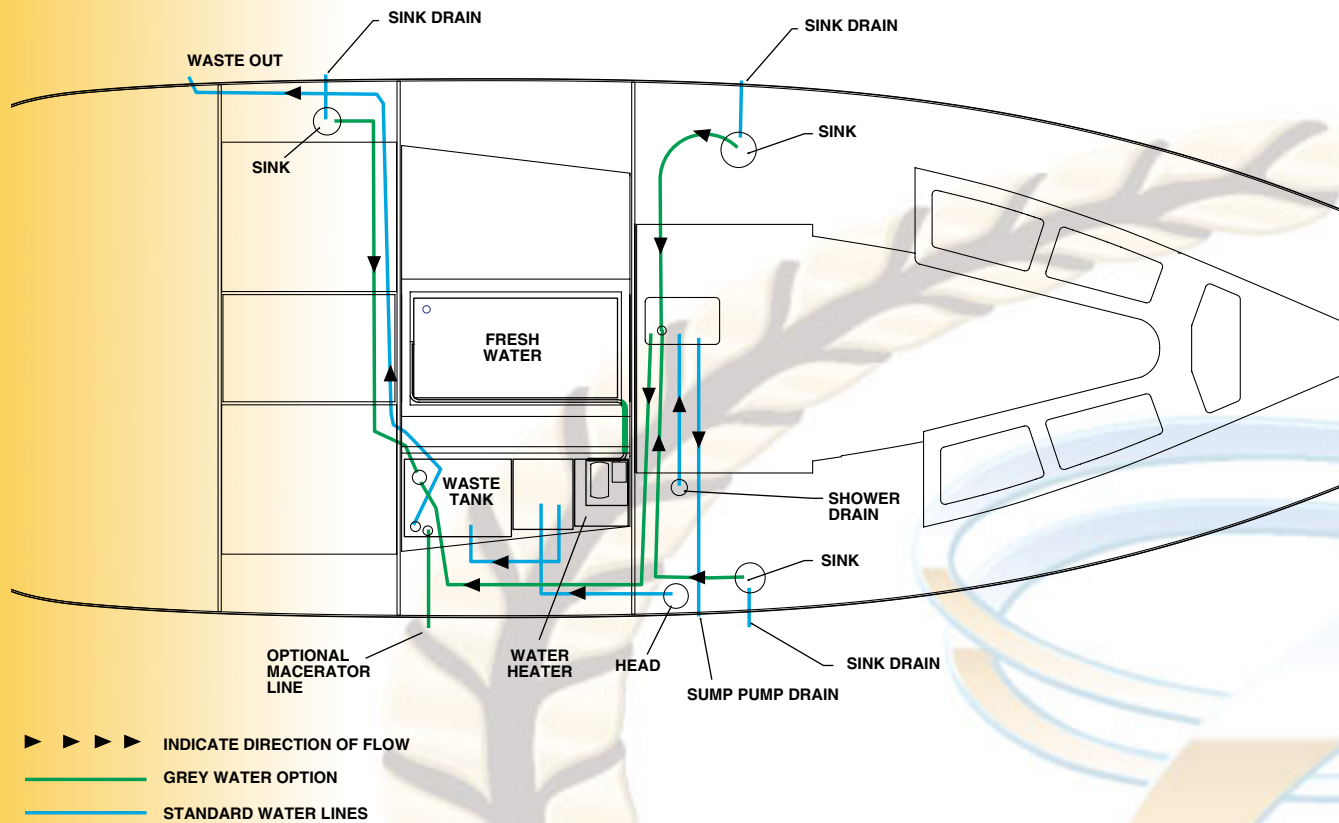

COB102

The optional grey water system stores waste water from the shower and sink drains in the waste tank. To clear the tank of waste water, you will need to use the dockside pump-out services provided at marinas. Hook a suction hose to the pump-out deck fitting marked WASTE and to the dockside pump. The marina will handle the proper disposal of the waste and may charge for this service.

The waste tank level indicator display panel shows the level of the water in the 28 gallon waste tank:

Red Light .....	Full
Amber Light .....	Mid
Green Light .....	Empty



**NOTICE:** No indication is given if the tank is 1/8 to 1/2 (mid) full.

## Raw Water

Your Cobalt 360 Performance Cruiser contains two raw water systems in addition to the engines. One is for the generator, the second is for the air conditioning unit.

Each raw water system will have its own thru-hull water intake, seacock and strainer. The seacock is very important. It protects the boat from sinking if a hose or fitting should fail. It is important to close any seacock not in use.

Your engines have their own raw water system for cooling. Refer to the propulsion unit operator's manual for engine cooling information.

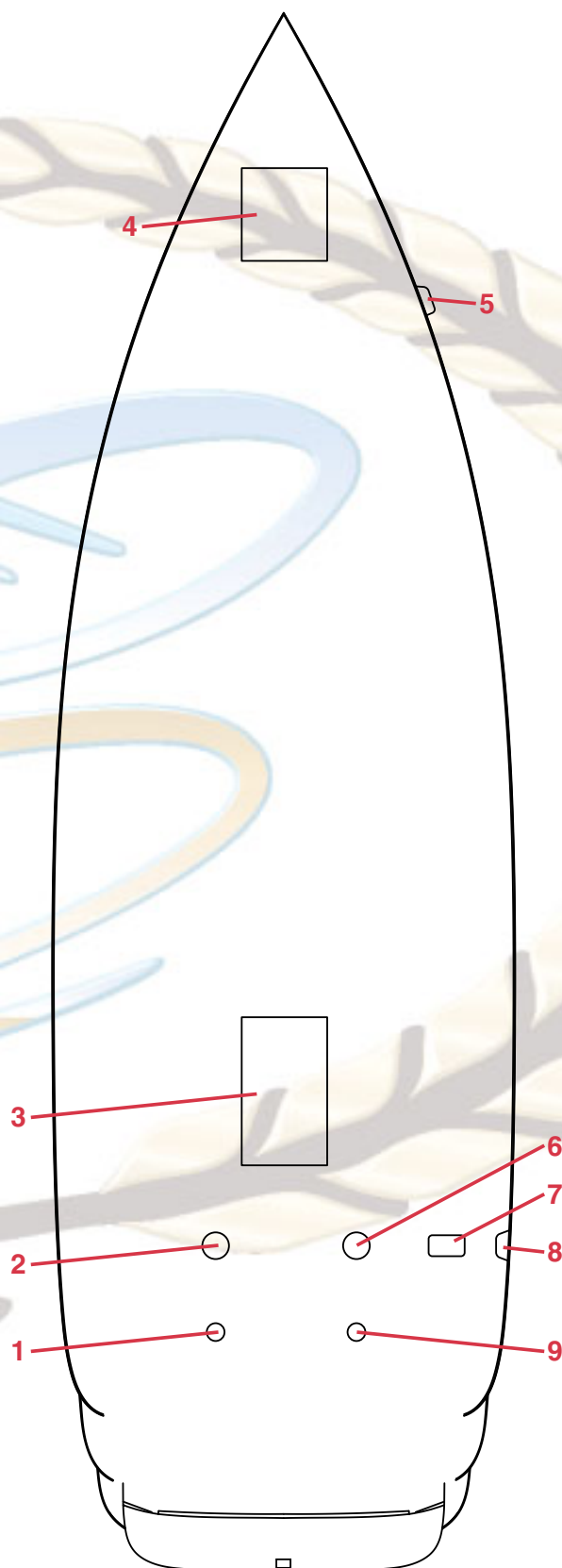

1. Generator Seacock
2. Generator Strainer
3. Generator
4. Air Conditioning Unit
5. Air Conditioning Water Discharge
6. Air Conditioning Strainer
7. Air Conditioning Pump
8. Generator Discharge
9. Air Conditioning Seacock

COB059

# CABIN DISTRIBUTION PANEL

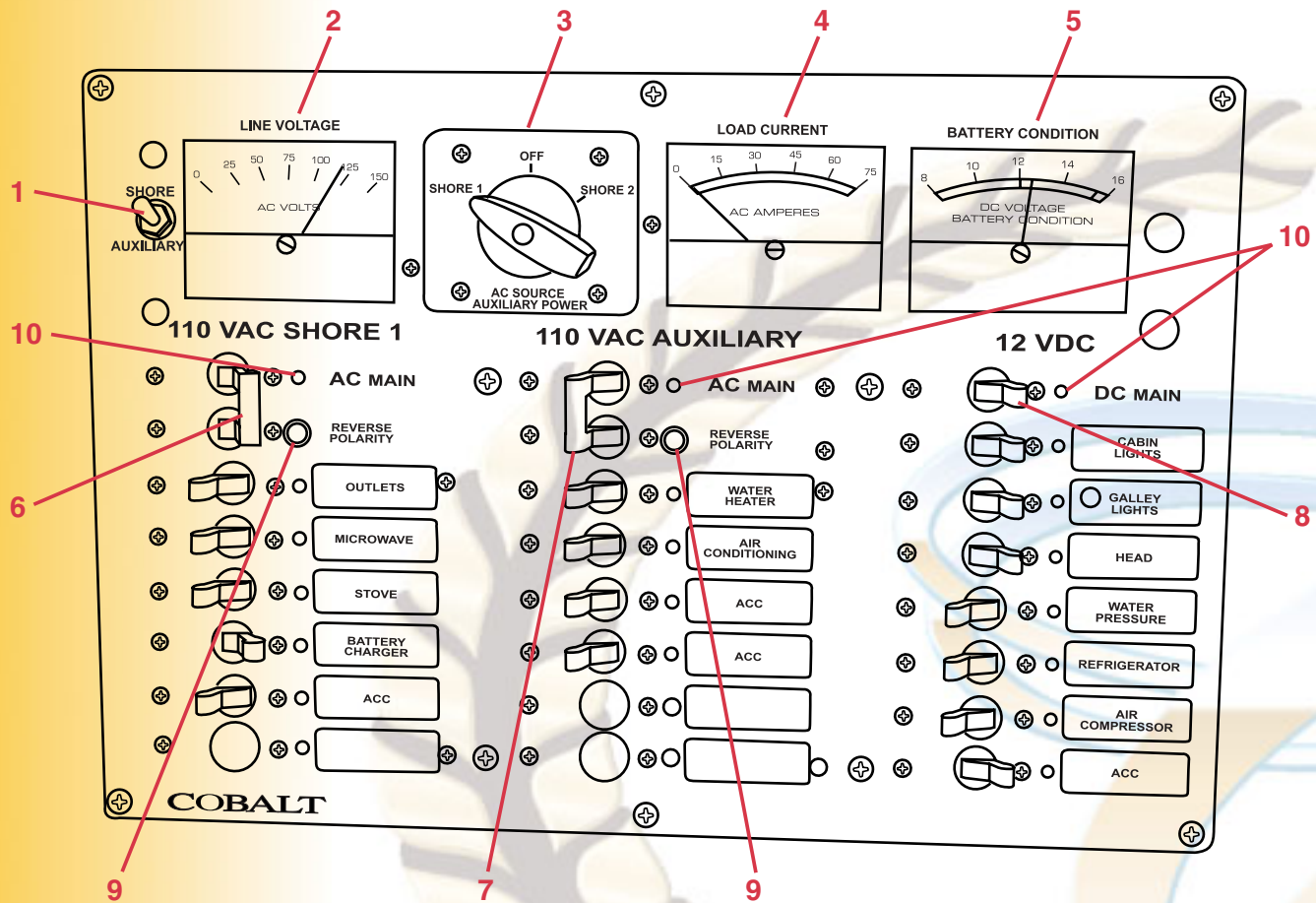

COB002

1. Voltmeter Selector Switch
2. AC Voltmeter
3. Auxiliary Breaker Source Selector Switch
4. Ammeter
5. DC Voltmeter

6. AC Main Breaker – Shore 1
7. AC Main Breaker – Auxiliary
8. DC Main Breaker
9. Reversed Polarity Lights
10. Indicator Lights

Your Cobalt 360 Performance Cruiser is equipped with two electrical systems: a 12-volt direct current (VDC) system and a 110-volt alternating current (VAC) system. Batteries power the 12 VDC system. Shore power, the optional generator or optional inverter supply the electricity for the 110 VAC system. The systems have a distribution panel located within the master cabin.

Check the circuit breaker if a particular piece of equipment or the boat lights stop working. A tripped circuit breaker indicates the circuit is overloaded. You should determine and correct the cause of a problem before resetting a circuit breaker. Please contact your Cobalt dealer if a circuit breaker keeps tripping.

Both the AC and DC circuits are controlled by a switch-type circuit breaker. When the indicator light next to the switch is illuminated, the circuit is activated. The circuit breaker functions in two ways. It allows you to manually enable or interrupt a circuit by moving the switch ON or OFF. They protect the system by automatically opening the circuit if a short or overloaded condition occurs.

**CAUTION**

**Do not reset a circuit breaker which has been automatically tripped without first detecting and correcting the cause of the problem.**

## DC ELECTRICAL

Your Cobalt 360 boat has a 12-volt negative ground DC system. The positive wire is hot, and feeds current from the batteries to all 12-volt equipment; the negative wire is the ground.

The DC electrical system panel in the cabin supplies electricity from the house battery to:

- Cabin lights
- Galley lights
- Head
- Fresh water pressure pump
- Refrigerator/freezer
- Air compressor
- Entertainment System
- Radar

The 12 VDC system consists of a voltmeter, a main circuit breaker and a series of switch-type circuit breakers. The voltmeter allows you to check the condition of the batteries.

Three battery switches are located under the port, aft cockpit seat cushion. Normal settings are starboard set to battery 1, port set to battery 2 and the house/generator set to battery 2, which is its independent battery bank consisting of two batteries located on the port side of the engine compartment. For emergency start only, set selector to ALL, then return to normal settings.

Circuit breakers under the switches are for items as labeled, helm, amp, trim tabs, bilge pump, and distribution panel.

The bilge pumps are wiring direct to the battery through BILGE PUMP breaker and will remain energized even if battery switches are turned off. All other items, including the CO monitors, will be disabled. **DO NOT OCCUPY BOAT IF CO MONITORS ARE DISABLED.**

A voltage sensitive relay is mounted next to the battery switches and automatically allows the starboard engine alternator to charge the house batteries.

To operate the 12 VDC system:

- Turn the battery switch labeled capacity HOUSE/GENERATOR, located under the port aft cockpit seat, to position 2.

- Switch the DC main circuit breaker to ON position. Indicator light next to the switch will illuminate.
- Activate the individual component circuit breaker.

## AC ELECTRICAL

### CAUTION

**Any modification performed on the boat's AC system must be made by a qualified marine technician. The modification must be checked to assure compliance with ABYC guidelines and National Electrical Codes.**

### Shore Power

### ! WARNING

**To minimize shock and fire hazards:**

- Turn the boat's shore connection switch to off before connecting or disconnecting shore cable.
- Connect shore power cable at the boat first.
- If reverse polarity light is activated, immediately disconnect shore power cable.
- Disconnect shore power cable at shore outlet first.
- Do not alter shore power cable connections.



1. Shore Power

COB150

When both shore power cords are plugged in, the AC SOURCE AUXILIARY POWER switch on the cabin distribution panel is set to SHORE 2 and the source selector switch set to SHORE, all AC equipment can be operated. Shore power cord 1 supplies power to the left column of breakers. Shore power cord 2 supplies power to the middle column of breakers.

Verify the main circuit breakers are turned on and that the reverse polarity light is off. If the light remains on, immediately disconnect the shore power cable at the shore outlet. Have your Cobalt dealer service the system before you use it. Switch the top double-pole AC main circuit breaker on the cabin distribution panel ON and then the respective branch circuit breakers below it as needed.

### Using Only Shore 1 Power Cord

Shore 1 cord powers the left column of circuit breakers on the distribution panel. Any of these circuit breakers may be used with only shore 1 plugged in.

The AC SOURCE AUXILIARY POWER switch located above the middle column of circuit breakers selects the power source for the middle breakers. The choices are:

- SHORE 1 – Pulls power from cord 1 to the middle circuit breakers.
- OFF – No power to the circuit breakers.
- SHORE 2 – Routes power from cord 2 to the middle circuit breakers.

The AC SOURCE AUXILIARY POWER switch on the distribution panel can be set to SHORE 1 to power the middle column of circuit breakers in addition to the left column. In this configuration, all components can be used with power supplied from shore 1 cord up to a maximum of 30 amps.

### Shore Power Connection

The shore power system requires a special, marine grade three-conductor cable to make a proper connection to the shore. Dockside connections and the boat side connections are plug-in. Boat side connections are also locked in position with a threaded locking collar to prevent accidental disconnection and enhance water resistance.

## WARNING

Plugs and receptacles for different systems are designed in non-interchangeable configurations. A plug from one system cannot fit into the receptacle of another system. Do not modify a shore power cable. Use only commercially available adapters for system modification.

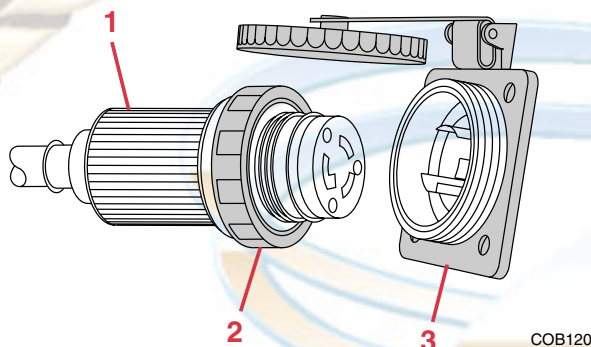

1. Shore Power Cord
2. Threaded Locking Collar
3. Boat Receptacle

COB120

To connect:

1. Turn off the boat's two main AC circuit breakers on the Cabin Distribution Panel.
2. If the outlet on the pier has a disconnect switch, turn the switch OFF.
3. Connect the shore power cable at the boat first.
4. Make sure the cable has more slack than the mooring lines.
5. Remove the cap from the outlet on the pier. Connect the cable to the outlet.
6. If your boat is equipped with an optional generator, turn the Shore/Generator switch located above panel in cabin to SHORE.



COB146

## 1. Shore/Generator Switch

7. Set the shore disconnect switch in the ON position.
8. If the reverse polarity warning light on the Cabin Distribution Panel is activated, immediately disconnect the cable from the shore outlet and contact your Cobalt dealer.

To Disconnect:



**NOTICE: If your boat is equipped with an optional generator and you wish to keep the AC appliances operating while underway, start the generator and turn the selector switch to GENERATOR and skip Step 1.**

1. Turn OFF the boat's two main circuit breakers.
2. If the shore outlet has a disconnect switch, turn it to the OFF position.
3. Disconnect the shore power cord at the shore outlet.
4. Disconnect the cable from the boat and close the cap.



## WARNING

Some marinas have been known to “break” shore power ground circuits to prevent electrolysis. Opening the ground circuit creates a potentially dangerous onboard shock hazard. Use caution when using a “break” shore power ground circuit.

Your Cobalt Performance Cruiser is equipped with an isolation transformer which isolates shore power from the boat's AC electrical system, reducing galvanic corrosion and the risk of electrical shock.

For further information regarding your shore power system, please consult your Cobalt dealer.

The AC portion of the distribution panel receives AC power from the shore power cable, optional generator or optional inverter. The panel distributes AC power through a double-pole main circuit breaker which in turn supplies the individual branch circuit breakers.

AC electricity operates the following equipment:

- Electrical outlets
- Microwave
- Stove
- Battery charger
- Water heater
- Air conditioning

The 110 VAC system consists of inlet breakers located in the aft, port motor box storage area, a shore/generator selector switch located above the distribution panel in cabin which contains a voltmeter, ammeter, two main circuit breakers and a series of switch-type circuit breakers.

The voltmeter monitors the AC voltage. Damage can occur to your equipment if the voltage is less than 105 volts. Do not use AC powered equipment if voltage is less than 105 volts.

The ammeter displays total amperage.

The main circuit breaker switch controls the individual component circuit breakers below it. This allows you to check for proper voltage and polarity immediately after making the shore power cable connection without damaging any equipment.

The reversed polarity light indicates if the polarity of the shore power has been reversed.

**! WARNING**

If reverse polarity light is activated, immediately disconnect shore power cable.

**Generator****! DANGER !**

Carbon monoxide gas (CO) is colorless, odorless and extremely dangerous. All engines and fuel burning appliances produce CO as exhaust. Direct and prolonged exposure to CO will cause **BRAIN DAMAGE** or **DEATH**. Signs of exposure to CO include nausea, dizziness and drowsiness.

**! WARNING**

Operate the blower for at least four minutes each time before you start the generator.

**CAUTION**

A diesel power generator may have a preheat switch used during starting. Do not exceed 30 seconds of preheat time or the manifold heater and plugs can be damaged.

The generator is located in the cockpit floor storage area. A controller mounted on the generator contains a Start/Stop switch, hour meter and a main output AC Circuit Breaker. A remote start panel located at the helm can also be used to start and stop the generator. Refer to **Section 3**.

The generator is used to provide AC power when shore power is not available.

1. Make sure the generator seacock (located forward of the engines) is open.
2. Make sure the AC Circuit Breaker, located on the Controller, is ON.



COB119

1. Generator AC Circuit Breaker
3. Turn OFF the selector switch located in the cabin.
4. Turn ON the generator's battery switch on the Battery Switch Panel located under aft port cockpit seat. Operate the blower for at least four minutes. Start the generator following the manufacturer's instructions. Allow generator to operate for at least one minute to stabilize voltage.
5. Turn the selector switch to generator.
6. Switch the main AC circuit breaker ON and then the respective branch breakers below it as needed.
7. Be sure to monitor the generator's oil pressure gauge and water temperature gauge at the generator control panel.
8. Do not operate the generator during boat high-speed operation.

**Battery Charger**

Your Cobalt boat is equipped with a multi-bank charger located on bulkhead forward of port engine. Anytime your boat is connected to shore power or the optional generator is running and the BATTERY CHARGER switch at the cabin distribution panel is on, the battery charger will operate and keep the batteries fully charged. Please refer to the battery charger operator's manual for additional information. The optional inverter is also a battery charger and will replace the standard battery charger.

## Inverter/Battery Charger

If an optional inverter/battery charger is installed, it will automatically charge the batteries if connected to shore power and CHARGE is selected on inverter remote panel located above the distribution panel in the cabin.

If the remote switch is OFF, the inverter will charge batteries when shore power is available, but will not provide AC power if shore power is disconnected.

If the remote switch is ON, the inverter will charge batteries when shore power is available, and will automatically draw from the battery bank and supply AC power to the SHORE 1 connection at the cabin distribution panel if the shore cord is disconnected. The middle column of breakers can also be powered by the inverter if the AC SOURCE AUXILIARY POWER switch is set to SHORE 1.

It is not recommended to use the inverter to power high amperage devices such as the hot water heater or air conditioner, as these components will quickly drain the battery bank.

For additional information, refer to the inverter operating instructions in your owner's packet.

### CAUTION

The inverter can still provide AC power even if the engine battery switches are off. To avoid the risk of electrical shock, disconnect all power sources before servicing the electrical system.

## TIE DOWN LOCATIONS

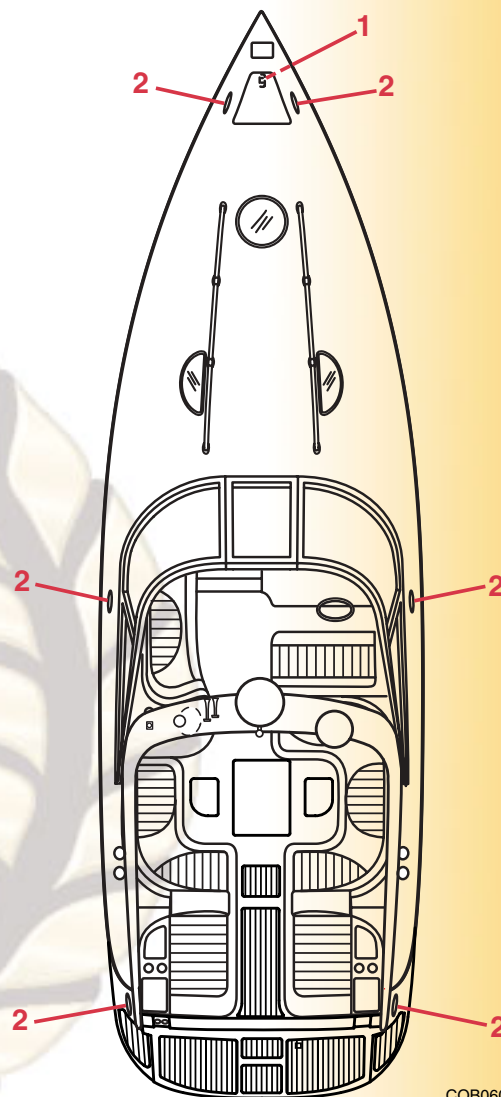

COB060

1. Bow Eye
2. Cleat



**NOTICE:** Only use properly positioned slings to lift your boat.

## FIRE SUPPRESSION EQUIPMENT

Your Cobalt 360 Performance Cruiser is equipped with a portable fire extinguisher, located at the helm.

A fixed automatic fire extinguisher that uses FE-241 (FM-200 for European requirements) as an extinguishing agent is mounted on the engine compartment forward bulkhead and another is mounted forward of the generator. These extinguishers are activated when the heat sensitive head reaches a predetermined temperature. The extinguisher discharges and saturates the engine and/or generator compartment, smothering the fire.

Inspect fire extinguishers for proper charge before operating the boat.

### **WARNING**

**When the fire extinguisher discharge occurs, turn off all engines, bilge blowers and electrical system components. Do not open the engine compartment hatch immediately. This will allow oxygen to the fire and flashback can occur.**

# Troubleshooting and Maintenance

This section describes how to care for and maintain your Cobalt 360 boat. It also includes a chart that will assist you in finding and correcting minor mechanical, electrical and boat system problems.

Some problems may require specialized skill and tools to correct them. See your Cobalt dealer for assistance.

A tool kit is provided to assist you with correcting minor mechanical and electrical problems. The tool kit is located on the upper side of the engine compartment hatch.



COB121

## SCHEDULED MAINTENANCE AND SERVICE

### Maintenance Schedule



### WARNING

The Teleflex® steering system must have all attaching hardware, bolts and nuts re-torqued according to manufacturer's specifications after a few hours of operation and at regular intervals thereafter. Loose or missing hardware may cause failure of the steering system resulting in injury or death. Please have your Cobalt dealer service the steering system at intervals.

Use the checks and maintenance information outlined in the section along with service information contained within the individual component operator's manuals supplied with your boat. It is extremely important that you read and understand the periodic maintenance tasks outlined in your operator's manuals (propulsion unit, generator and other accessories) because those maintenance tasks are not repeated in this manual.

Use the following chart to establish your maintenance routine. Detailed information concerning the task is listed in this section.

Frequency	Task
Break-in	Refer to propulsion unit operator's manual.
	Refer to generator operator's manual.
Before Every Use	Test operation of carbon monoxide detectors.
	Check fluid levels.
	Check seacocks for leaks and ensure handles are secure.
	Check seawater strainers for leaks and accumulation of debris.
	Check generator's fuel/water separator.
	Check exhaust system for leaks.
	Check fuel system for leaks.
	Check fire extinguishers.
	Check battery charge.
	Every 50 Hours
Inspect propellers for damage.	
Every 100 Hours	Test for proper operation of the ignition safety switch.
	Clean bilge area.
Monthly	Test GFCI outlets.
	Check self-sacrificing anodes.
Quarterly	Have your Cobalt dealer perform scheduled maintenance as outlined in this section.

### Break-In

Careful break-in allows internal engine components to "seat" properly, resulting in maximum engine life and performance. Refer to the propulsion unit and generator operator manuals for manufacturers' break-in requirements.

### Before Each Use

1. Test for proper operation of the two carbon monoxide detectors; refer to the carbon monoxide detector operator's manual.
2. Check fluid levels of fresh water tank, waste holding tank and trim tab reservoir.
3. Check the air conditioning and generator seacocks and hoses for leakage. If you notice a leak, see your Cobalt dealer.

**CAUTION**

- Seacocks can only be replaced when the boat is out of the water.
- Be sure a seacock is in the closed position before replacing a hose.



COB067

1. Generator Strainer
2. Generator Seacock
3. Air Conditioning Strainer
4. Air Conditioning Seacock

4. Check the air conditioning and generator seawater strainers for leaks and accumulation of debris.
  - If a hose is leaking or damaged, close the appropriate seacock. Consult your Cobalt dealer for repairs.
  - If debris is seen within the container, close the appropriate seacock and remove the strainer cover. Lift strainer from container and thoroughly clean. If the container is full of sediment, remove the plug at the bottom of the container and allow water to drain into the bilge. Remove the container and clean any sediment. Install the container and plug. Install strainer in container and secure cover. Open the seacock and check for leaks.

**CAUTION**

**Seacock must be in the closed position before servicing a strainer.**

5. Start both engines and the generator. Check all exhaust systems for leakage. If you notice a leak, see your Cobalt dealer.
6. Check all fuel lines and connections at fuel tanks, engines and the generator for leakage. If you detect a fuel leak, immediately see your Cobalt dealer.

**! WARNING**

**Do not operate your boat when a fuel leak is detected. All fuels are combustible. A fuel leak must be repaired before starting the engines or the generator.**

7. Check the portable and automatic fire extinguishers for proper charge.
8. Check battery charge of both engine batteries and the generator battery. Be sure that the batteries can start both engines and the generator before proceeding on your cruise.

### Every 50 Hours

1. Be sure to clean seawater strainers as described in **Before Each Use, Step 3**.
2. Check propellers for damage. If bends, cracks or other damage are found, consult your Cobalt dealer for service. Do not continue to use badly damaged propellers. Using damaged propellers within time may damage the drive units.

### Every 100 Hours

1. Clean the bilge area. Make sure all drain passageways are clear. Refer to **Bilge**, in this section, for cleaning instructions.

### Monthly

**! WARNING**

**With the engines running, pull the lanyard off the ignition safety switch. Both engines must stop running. If neither or only one engine stops running, immediately see your Cobalt dealer for service.**

# Troubleshooting and Maintenance

1. Test each GFCI outlet circuit breaker feature. Push the test button on each outlet. Power should be interrupted to all the outlets onboard. Press the reset button to restore power. If power is not interrupted, consult your Cobalt dealer.

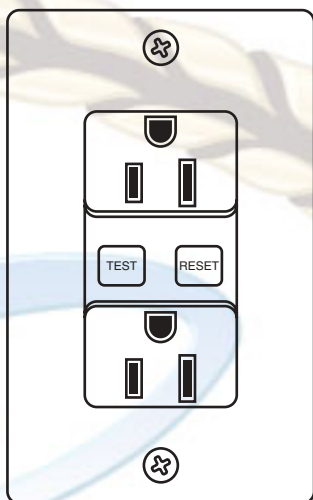

COB068

2. Check condition of all self-sacrificing anodes. If anode shows deterioration of 50% or more, it must be replaced. Refer to the propulsion unit operator's manual for additional information.

## Quarterly

Have your Cobalt Dealer perform the following scheduled maintenance:

1. Clean the fresh water filter located under the floor in mid-berth area.
2. Fill, pressurize and inspect the fresh water system for leaks and proper component operation.
3. Inspect the steering, shift and throttle systems for proper operation.
4. Check all batteries for proper electrolyte level.
5. Check trim tab pump fluid level.

## UNSCHEDULED MAINTENANCE

A problem with a piece of equipment can occur at anytime. Be aware of a malfunction. Have a problem serviced immediately by your Cobalt dealer.

## Engine/Propulsion/Cooling System

If a problem occurs with your engine, propulsion unit or the cooling system between the scheduled maintenance cycle, immediately notify your Cobalt dealer. Do not allow a problem to go unattended. By doing so, a minor repair could become a major overhaul.

## Electrical System

Have your Cobalt dealer repair all electrical problems. An electrical problem must be treated seriously.

### **WARNING**

Whenever checking for electrical problems, use extreme caution. Gasoline is flammable.

## Fuel System

Do not operate your boat knowing you have a fuel system problem. Upon discovery of a fuel system problem, immediately notify your Cobalt dealer for repair.

### **WARNING**

Do not operate your boat when a fuel leak is detected. All fuels are combustible. A fuel leak must be repaired before starting the engines or the generator.

## Water System

### Fresh Water

Before departing on a cruise, check the level of fresh water onboard. Fill the fresh water tank and verify for proper operation on the fresh water system. If a problem is found, have the problem repaired at your earliest convenience.

### Gray Water

Periodically check the level of waste water in the waste tank. Have your waste tank pumped out when needed and be sure that the waste system is always operating properly.

## INTERIOR/EXTERIOR CARE

The best way of taking care of your Cobalt 360 Performance Cruiser finish is with prevention and proper care.

### Hull/Deck

The finish on your Cobalt boat is known as gelcoat. The gelcoat used by Cobalt is the finest available on the market today. With all its properties, it is not impervious to the elements and many types of water conditions.

### Cleaning Hull/Deck

A multi-purpose boat soap\* should be used to clean exterior fiberglass/gelcoat surfaces on your Cobalt boat after each use. This product, depending upon the ratio mixed, is designed to clean anything from dirty hulls and decks to greasy engines. Always rinse and wipe off the finish with a damp towel or chamois.

A fiberglass restorer/wax\* should be used to remove heavy oxidation, characterized by a chalk/faded surface as well as rust and exhaust stains. This product will not only remove the oxidation but also leaves a wax protection on the cleaned surface in one easy application.

### Hull/Deck Care

Paste wax\* will help retard UV light damage. We suggest three coats be applied at the end or the beginning of the season, depending on the type of winter boat storage (covered, enclosed storage facility), and again mid-season.

To extend the life of your gelcoat finish, use a Cobalt marine mooring cover totally covering the top deck of the boat for maximum protection. Additionally, if your boat is to be stored where the sun is constantly on the side or transom of the boat, you should consider having some custom skirting made to compliment the mooring cover. Tonneau covers will supply adequate short term protection to the interior, but will not protect the gelcoat finish. Please check with your Cobalt dealer for further information on the subject.

\*3M carries a complete line of fiberglass care products.

### Upholstery

The vinyl fabric in your Cobalt boat's interior has been specially selected to take the tough punishment of the elements and hard usage of an active boater. Avoid sharp objects that may cut or tear your vinyl.

The vinyl in your Cobalt has been coated with PreFixx protective finish. It's designed to be cleaned easily, over and over, without showing signs of wear. With PreFixx protection, it is possible to remove stains that could never be removed before. There are three families of sunscreen ingredients which may contribute to the staining of the vinyl in your Cobalt boat.

- Aminobenzoic acids - e.g. PABA
- Hydroxy benzophenones – e.g. Oxybenzone
- P-methoxycinnamic acid – e.g. Octyl methoxycinnamate

This list should not be considered inclusive, although it does represent a large selection of sunscreens which are known to stain vinyls, even treated with PreFixx. In actuality, almost any sunscreen with a high percentage – two percent or above – of active ingredients is a potential stainer.

Vinyl staining from suntan lotions is not covered by the vinyl manufacturer or Cobalt warranties.

Special care should be taken to prevent dark colored rubber products or Sunbrella™ canvas from coming in contact with the vinyl upholstery.

### Care and Cleaning of Vinyl

Remove ordinary dirt and smudges with a mild soap and warm water solution. Dry with a soft, lint-free cloth or towel. For more difficult stains, use a stronger detergent. Follow the detergent manufacturer's instructions closely.

### Special Cleaning Problems

The following steps are recommended to clean stains on PreFixx-protected vinyl upholstery. Many difficult stains can be removed when these cleaning agents are used in the following order.

#### Step 1 Cleaners

Rinse cleansed area with fresh water and dry with a clean cloth.

- Formula 409™ or Fantastik™
- Clorox™ Soft Scrub® with bleach
- Household cleaners and bleaches

# Troubleshooting and Maintenance

## Step 2 Cleaners

Solvent-type cleaners to be liberally applied with a cloth, damp sponge or fine bristle brush. Rinse cleansed area with fresh water and dry with a clean cloth.

- Rubbing alcohol (isopropyl alcohol)
- Lighter fluid (naphtha)

## Step 3 Cleaners

Strong, active cleaners to be applied with a soft cloth or damp sponge. Use no more than six rubs: if the stain persists, contact Cobalt Customer Service. Dry with another cloth, then rinse with clear water and dry.

- Nail polish remover (acetone/water)



**NOTICE: It is extremely important to clean the stained area as quickly as possible, making sure the recommended cleaning steps are followed in order.**

Recommended Cleaning Solutions for Prefix-Coated Nautolex Vinyls

Staining Agent	Cleaning Step
Spray paint	1 – 2 – 3
Ballpoint pen	1 – 2 – 3
Lipstick	1 – 2 – 3
Yellow mustard	1 – 2 – 3
Bird droppings	1 – 2 – 3
Crayons	1 – 2
Eye shadow	1 – 2
Oily spot	1 – 2
Petroleum products	1 – 2
Coffee	1
Tea	1
Hair oil tonic	1
Blood	1
Urine	1
Grape juice	1
Olive oil	1
Chocolate	1
Ketchup	1
Baby oil	1



**DANGER**



**Flammable liquids are extremely dangerous and should be used only in well ventilated areas. Avoid open flame or spark.**

## Dark Stowage Areas

Often, when a boat is stored completely covered or in a dark building, the vinyl will darken or become “dingy” looking. If this happens, simply place the boat in direct sunlight for a few hours and the vinyl will brighten up.

## Leather Care

For spots and spills, wipe up excess liquid immediately with a clean absorbent cloth or sponge. If necessary, use clean lukewarm water only and let air dry naturally. If water is used, clean the entire area where the spot occurred. For example, clean the entire seat cushion or entire arm. Do not dry wet areas with hair dryers.

For stubborn spots and stains, use a mild non-detergent cleaner such as a bar of Ivory Soap™ or Amway™ L.O.C. Apply the soap to a clean wet sponge, wash, then rinse well. Let air dry naturally.

For butter, oil or grease, wipe any excess off the leather with a clean dry cloth, then leave it alone; the spot should dissipate into the leather in a short period of time. Do not apply water or try to wash a butter, oil or grease spot.



**NOTICE: Do not use saddle soap, cleaning solvents, furniture polish, oils, varnish, abrasive cleaners, soaps or ammonia water.**

## Carpet

Vacuum the carpet on a regular basis. Use household carpet stain removers and cleaners to clean the carpet.

## Cabinetry

Clean with any water rinseable non-abrasive cleaner.

## Windshield

To keep the windshield clean, use a non-abrasive glass cleaner applied with a soft cloth. Do not use harsh detergents, solvents, chemicals or dry cloths. These items will scratch the surface.

## Bilge

Keep the bilge area as clean as possible. Use a vacuum cleaner to remove debris from the bilge area. Oil and greasy dirt will accumulate over time and can be normally removed using soap and water. If necessary, consult your Cobalt dealer for recommendations on special bilge cleaning and absorption products.

## Stainless Steel and Chrome

Stainless steel, though highly resistant, is still capable of rusting, particularly in the marine environment. Initial signs of rust and corrosion, left untreated, may result in pitting and permanent damage to components. The following steps will help protect against such occurrences:

### Preventive Steps

Clean and wax metal brightwork twice yearly and prior to extended storage. In saltwater or other harsh environments, more often as needed. Many polish/cleaners are commercially available that contain wax for one-step convenience.

Rinse with fresh water and wipe dry with towel or chamois after each use.

### Cleaning Stainless Steel

Remove rust or corrosion promptly using a good metal cleaner/polish. Delay may contribute to permanent finish damage. Do not use steel wool or other coarse abrasives, or clean with acids or bleach. Apply metal or automotive wax after cleaning for additional protection.

### CAUTION

**These solvents are highly flammable. Exercise proper care in cleaning and notify personnel in dangerous area. Wear rubber gloves during all cleaning activity. Use caution in cleaning around stitching and wooden or other decorative trim, since these solvents could seriously damage such areas.**

Should you have reason to replace hardware or fasteners, be certain that replacements are correct materials. Consult your Cobalt dealer for further information.

Use a Cobalt mooring cover to provide additional protection.

## Canvas

The boat top and other canvas items supplied on your Cobalt boat are manufactured from top quality materials to provide you with years of trouble free service. The following information on the care, cleaning and proper storage of the fabrics and fasteners that make up your marine canvas is provided to help you maintain the appearance and ease of operation.

Cobalt uses Sunbrella®, a woven fabric made of 100% solution dyed acrylic fiber. It is very colorfast and will withstand long-term exposure to the sun (ultra-violet) without excessive fading or deterioration.

### Cleaning Canvas

Canvas should be cleaned regularly before substances such as dirt, roof particles, etc., are allowed to accumulate on and become embedded in the fabric. The fabric can be cleaned without being removed from the installation. Simply brush off any debris, hose down and clean with a mild solution of natural soap in lukewarm water (no more than 100°F). Rinse thoroughly to remove soap. **DO NOT USE DETERGENTS.** Allow to air dry.

### CAUTION

**Under no circumstance are these fabrics to be put in hot water. Under no circumstances are these fabrics to be run through the hot drying cycle of an automatic dryer. Fabric should be line dried. Under no circumstances are these fabrics to be steam pressed at a dry cleaner.**

### Special Cleaning Problems

For heavily soiled fabric, remove the top from frame. Soak the fabric in a solution that has been mixed to the following proportions:

- 1/2 cup of Clorox
- 1/4 cup of Ivory Snow, Dreft™ or Woolite™
- Per each gallon of lukewarm water (water should be no more than 100°F)

# Troubleshooting and Maintenance

Allow the fabric to soak until the bleach has killed the mildew and the stains can be brushed out with a common kitchen scrub brush. Rinse the fabric thoroughly in cold water to remove all of the soap. This may require rinsing several times. Incomplete rinsing can cause deterioration of sewing threads and prohibit the fabric from being properly retreated. Allow the fabric to air dry completely.

Sunbrella may also be dry cleaned. DO NOT STEAM PRESS OR DRY IN AN ELECTRIC OR GAS DRYER. Sunbrella is thermoplastic or heat sensitive. Excessive heat can damage and shrink the fabric. This method of cleaning may remove part of the water and stain repellency that was applied to the fabric during its manufacture. The fabric should receive an application of an air-curing treatment such as "303 HIGH TECH FABRIC GUARD."

## Canvas Care

Do not store canvas wet or in an unventilated, moist area.

Roll the canvas instead of folding. This is of particular importance on side curtains or any part with the clear vinyl "glass." Handle the clear vinyl carefully. It is soft and very prone to scratching. Roll the top carefully around the bows and cover with the storage boot provided.

## CAUTION

**Your Bimini Top and Enclosure are designed and intended for short-term use only. Do not use for storage. Under no circumstances should the boat be towed with the boat top in the upright position.**

## Clear Vinyl

The clear vinyl "Isinglass" used in your bimini enclosure is very reactive to heat and cold. Be careful unrolling the vinyl in cold weather to prevent cracking. Keep vinyl side curtains from touching the bows (tubing) to prevent burning the vinyl. If the boat is stored with enclosure in place, heat buildup inside of the boat may discolor the vinyl. Handle the clear vinyl carefully. It is soft and very prone to scratching.

## Cleaning Clear Vinyl

Use a soft cloth; clean with a solution of Ivory or Lux™ soap, liquid or flakes, and lukewarm water. Allow to air dry. Never use any type of abrasive cleanser; it will scratch the glass. Regularly apply a UV screening agent such as "303 PROTECTANT" to keep the vinyl soft and flexible.

## Zippers

When zippers are new, they can be a little difficult to zip. Zip carefully without forcing. They will loosen with use. A zipper lubricant may be used to help new zippers as well as maintaining long trouble free service. The most vulnerable part of the zipper are the starting points. Use care when starting zipper to prevent damage.

## Snap Fasteners

Fasteners should be unsnapped as close to the button as possible. Never remove canvas by pulling roughly on one edge of the material. This can damage the canvas as well as the fastener. If the snaps become difficult to unsnap, rub candle wax or paraffin around the stud and inside the socket. Lubricants such as Vaseline™, Chapsick™, or WD-40™ silicone spray can be used, but care must be taken so the lubricant does not stain the canvas or other surfaces it may contact.

## Teak Wood

Regular cleaning and oiling of teak wood will maintain its original appearance. Use a teak wood cleaner that will penetrate the pores of the wood and cleanse them of dirt and stains. Do not use caustic cleaners. They will damage the wood. Immediately after cleaning, apply an oil sealer with a soft cloth. Carefully follow the sealer manufacturer's instructions.

## CAUTION

**Teak wood sealers can be harmful to other materials. Make sure you thoroughly remove any of the oil that has come in contact with any vinyl, gelcoat or other material. Teak wood should not be varnished as the natural oils will cause poor adhesion.**

## Arch Maintenance



**NOTICE: Improper covering of the boat for storage can result in damage to the arch's finish. The boat covering used for storage must be ventilated to allow it to properly "breathe" and should not be pulled tight to painted surfaces. Improper covering can trap moisture on the painted surfaces causing loss of gloss, blistering or delaminating of the topcoat.**

Regularly clean the arch with AWLWASH™ wash concentrate to avoid buildup of dirt, grease and other contaminants which can cause premature aging of the painted surface of the arch. This premature aging can cause the finish to appear dull. Follow the directions supplied with AWLWASH when mixing your boat wash. Additional information about AWLWASH is furnished in your owner's packet.

### Arch Waxing



**NOTICE: Do not use traditional waxes on the arch. Traditional waxes will break down rapidly causing the topcoat to appear yellow and attract dirt.**

Traditional waxes offer no benefit to protect the finish on the arch. Using traditional waxes increases the need to maintain the wax increasing overall maintenance.

Use AWLCARE™ protective polymer sealer to protect the finish on the arch. AWLCARE leaves a non-yellowing protective polymer coating which lasts through multiple washings. With regular applications, AWLCARE increases resistance to damage from acid rain and other environmental pollutants. Additional information about AWLCARE is furnished in your owner's packet.

## CORROSION PROTECTION

### CorrosionX

One of the issues associated with owning a boat is corrosion, which, ironically, is often caused directly by the marine environment. If you operate a boat in salt water, you will be impressed with the rapid growth of corrosion in just a few weeks.

Since we recognize that your purchase of a Cobalt Boat was a major financial decision, we

want you to be happy about your choice for years to come. After consulting with our dealers and operators throughout the country, we found that regular applications of a product called CorrosionX will keep your boat operating at peak efficiency, free of corrosion. To assist you, we have included a small can of CorrosionX in the optional salt water kit. Minimally, it should be applied to the following areas and components in the time frames specified:

#### Topside

Spray or wipe a light coat of CorrosionX on all rails, stanchions, cleats, cleat bolts and other metal fixtures/fittings up on deck. Treat hinges, locks, closure mechanisms and sliding tracks of doors and windows. If sprayed on, wipe with cloth to remove excess. A very light coat is all it takes and it should be applied every two months if operating in salt water and every four months in freshwater operations.

#### Inside the Bulkhead

Once a year, spray electrical connections, fuse panels, antenna bases, etc. Light sockets should be treated at two or three month intervals. Every six months, treat plumbing connections in the galley and head areas. Once a year, apply to hinges, locks and sliding tracks of doors and windows to keep them properly lubricated and functioning smoothly.

#### Other Areas

Treat hydraulic cylinder shafts for steering and other operating mechanisms once a month. Spray the entire engine, including engine mounts, every six months. Treat the bilge pump housing and connections plus other items in the bilge area once every three months. Thru-hull fittings and seaocks should also be treated every three months. Fuel line fittings at the fuel tank should be treated every six months.

CorrosionX is a multi-functional product with universal application. A good rule of thumb: if it rusts or corrodes, if it needs lubricating or if it's rusted shut and needs to be broken apart, it's a potential application. If you have any questions about CorrosionX, check the manufacturer's web site: <http://www.corrosionx.com> or call 800-638-7361.

Corrosion destroys underwater metal parts and can occur in fresh or salt water. Salt, brackish and polluted waters will accelerate corrosion.

# Troubleshooting and Maintenance

## Galvanic

Galvanic corrosion (electrolysis) can result in serious damage to any metal component of your Cobalt boat that is in the water. Galvanic corrosion is the deterioration of metals due to the effects of electrolytic action. When dissimilar metals are immersed in a conductive fluid such as salt water, an electric current is produced, similar to the action of a battery. The softest of the metals will be the first to become damaged.

Galvanic corrosion can occur in fresh or salt water, however, salt, brackish and polluted waters accelerate galvanic corrosion.

A self-sacrificing anode can be mounted to your Cobalt boat to help prevent damage to metal components from galvanic corrosion. The anode will require frequent inspections. If the anode shows deterioration of 50% or more, it must be replaced for continued protection.

### CAUTION

Do not paint an anode, its fasteners or its mounting surface. Painting will reduce the anode's corrosion protection capabilities.



**NOTICE:** Refer to the propulsion unit operator's manual for their requirements for galvanic corrosion protection.

## Salt Water

Wash the entire boat after each use in salt water. If you continue to operate in salt water, the entire boat should be protected against salt water damage as described in **Interior/Exterior Care**, in this section.

Refer to the propulsion unit operator's manual for manufacturer's salt water operating recommendations.

## Marine Growth

If marine growth is a problem in your boating area, it may be necessary to apply anti-fouling paint to the hull to slow growth and prevent gelcoat damage. Consult your Cobalt dealer for recommendations.

## LIFTING THE BOAT

To prevent structural damage to your Cobalt Performance Cruiser, the proper procedure must be used when lifting your boat. Only use appropriate style lifting slings to lift the boat.

### Using Lifting Eyes

Your Cobalt boat is not equipped with lifting eyes. Slings must be used to lift the boat.

### Using Lifting Slings

The only recommended method of removing the boat from the water is to use lifting slings. Slings must be the flat, wide belting-type. Do not use cable-type slings. The spreader bars used with the slings must be long enough to avoid pressure to the gunwales.

Two sling location decals on each side of the hull indicate the general area where each sling should be located. Slings may need to be adjusted forward or aft of the decals for your particular boat.

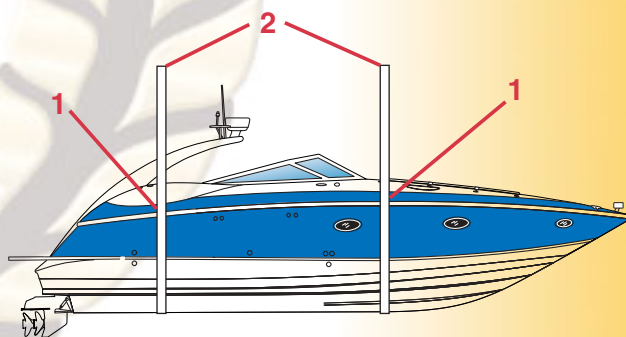

COB065C

1. Sling tag location
2. Flat, wide-belted sling

## Storage Cradle

Only use a storage cradle to store your boat when it's not in the water. A storage cradle will provide proper support and prevent stress on the hull. Position the storage cradle as close to the sling tag locations as possible. Use caution not to damage any underwater fittings.

The storage cradle must completely touch the hull for proper support. Avoid any gaps between the cradle and the hull.

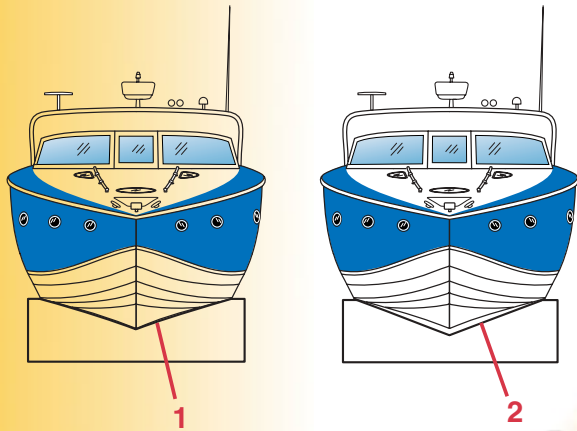

COB064C

1. Hull completely on cradle — right
2. Gap between hull and cradle — wrong

Store your Cobalt boat on a storage cradle with the bow slightly elevated; in other words, the same attitude as if the boat were floating at rest. If the boat is stored with the bow down, moisture will not be able to move to the engine bilge area and out of the boat. Remove the transom drain plug. Be sure that all compartments in the bilge completely drain. Mold and mildew may form as a result of the inability of moisture to escape.

## STORAGE/WINTERIZATION

Preparing for winter lay up is important. In frigid zones, be particularly attentive to items that can be damaged by freezing. Freeze damage is not covered by warranty.

The following items require special attention for winterization. Have your Cobalt dealer perform winterization procedures for the following:

- Engine cooling and exhaust systems
- Fuel system
- Batteries
- Hot water heater
- Air conditioning
- Generator and muffler
- Waste water system
- Fresh water system
- Gray water system
- Ice maker

After the boat has been properly positioned on a storage cradle, thoroughly wash the hull, deck and interior compartments. Allow a couple of days of air drying before covering the boat, store all cushions in the open position and open all storage areas. This will help prevent mold/mildew from forming. Perform preventative maintenance to the interior and exterior of your boat following the information in **Interior/Exterior Care**, in this section.

Cover the boat with the mooring cover. If a temporary poly cover, such as shrink wrap, is used, your Cobalt dealer will install several vents to provide adequate ventilation to prevent mold or mildew.



**NOTICE:** For stowage, we recommend an optional mooring cover of 100% SharkSkin™ polyester. Do not use your bimini enclosure or tonneau cover, for long term storage. These canvases were not designed for long term storage and do not provide good protection for your boat. Adequate ventilation is not possible and mold/mildew will form. For more information on appropriate covering for long term storage, please see your Cobalt dealer.

## Re-activating the Boat After Storage

Have your Cobalt dealer prep your boat for the upcoming boating season. There are many systems that require special attention to ensure your boat is in proper operating condition.

- Carbon monoxide detectors
- Engine's cooling, exhaust and lubrication systems
- Fuel and exhaust systems
- Hot water heater, refrigerator/freezer, stove
- Air conditioning
- Generator and muffler
- Fresh water system
- Waste water system
- Gray water system
- Batteries

# Troubleshooting and Maintenance

It is very important that both the engine and generator fuel systems and their exhaust systems be thoroughly inspected and repaired, if necessary, before operating the boat. Also, all of your accessory exhaust systems must be in proper operating condition.

## **WARNING**

Failure to inspect the fuel system could allow fuel leakage to go undetected, becoming a fire or explosion hazard.

## **DANGER**

Carbon monoxide gas (CO) is colorless, odorless and extremely dangerous. All engines and fuel burning appliances produce CO as exhaust. Direct and prolonged exposure to CO will cause **BRAIN DAMAGE** or **DEATH**. Signs of exposure to CO include nausea, dizziness and drowsiness.

## TROUBLESHOOTING

The following chart will assist you in locating and repairing a minor problem. Please have your Cobalt dealer assist you with service issues.

### Logic Tree Chart

## **WARNING**

- Gasoline is flammable. Use extreme caution when handling gasoline.
- Whenever checking for electrical problems use extreme caution. Gasoline is flammable.
- Battery acid can cause blindness if splashed in eyes, burning of skin.
- Disconnect battery cables at the battery before making checks or adjustments around the engines and electrical components.

Your Cobalt boat is equipped with an ignition safety switch located on the lower lip of the dashboard. Make sure the lanyard is installed with the switch holding the lanyard in place. Please consult your Cobalt dealer.

## Engine

For further troubleshooting information other than given here, refer to the propulsion unit operator's manual.

Symptom	Possible Cause
Engine will not crank	Lanyard – install on ignition safety switch.
	Battery switches – turn switches to ON position.
	Shift position – check to see that levers are in start or neutral position.
	Battery condition – verify batteries are fully charged.
	Starter connections – check connections and tighten. If solenoid clicks when attempting to start engine, check battery connections. If condition persists, see your Cobalt dealer.
	Engine circuit breaker – verify breaker is in operating position.
	Faulty ignition switch – see Cobalt dealer.
Engine problem – see your Cobalt dealer.	
Engine cranks but will not start	Fuel valves – be sure fuel valves are open.
	Contaminated fuel – see Cobalt dealer.
	Engine problem – see Cobalt dealer.
Low starter speed	Weak or bad battery – see Cobalt dealer.
Engine runs erratically	See your Cobalt dealer.
Engine vibrates	Propeller condition – shut off engines. Check for bent, broken or damaged propeller. Check for weeds on propeller.
	Engine problem – see your Cobalt dealer.
Engine runs but boat makes little or no progress	Fouled or damaged propeller – shut off engines. Check for weeds on propeller, bent or broken propeller. See your Cobalt dealer.
Performance Loss	Throttles not fully open – check to see that both throttles open fully at engines.
	Improper fuel – fill tanks with correct fuel.
	Overheating – immediately turn off the engines and contact your Cobalt dealer.
	Boat overloaded – reduce load.
	Boat trim – distribute boat load evenly.
	Improper propeller selection – see Cobalt dealer.
	Excessive bilge water – check for excessive water, drain bilge.
Boat hull condition – clean if marine growth is present.	

# Troubleshooting and Maintenance

## Electrical

### CAUTION

Correct a problem with the electrical system before resetting a circuit breaker.

Symptom	Possible Cause
Electrical component will not function	Circuit breaker tripped or in the OFF position – correct the problem and reset; turn circuit breaker on.
Dim or no lights	Circuit breaker tripped or in the OFF position – correct the problem and reset; turn circuit breaker on.
	Battery discharged – charge battery.
Generator will not start	Battery switch in OFF position – turn switch to ON position.
	Engine Problem – see Cobalt dealer.
No AC power	Circuit breakers tripped or in the OFF position – correct the problem and reset. Breakers are located in aft, port motor box storage and on the cabin distribution panel.
	Make sure shore/generator selector switch is positioned correctly.
	Ground fault circuit interrupter tripped – reset button on the outlet and test. If problem exists – see your Cobalt dealer.

## Plumbing

Symptom	Possible Cause
No water at shower or sinks	Fresh water pump circuit breaker tripped or in the OFF position – correct the problem and reset; turn circuit breaker on.
	Fresh water tank empty.
	Fresh water pump defective – see Cobalt dealer.
	Filter plugged – clean filter located at the tank under mid-berth.
Low water pressure at all sinks and shower	Damaged fresh water pump – see your Cobalt dealer.
Low water pressure at only one sink	Restriction or obstruction in water line.
Head will not flush	Head circuit breaker tripped or in OFF position – correct the problem and reset; turn circuit breaker ON.
	Line to waste tank blocked – see your Cobalt dealer.



## OPERATION QUICK REFERENCE

Your safety, the safety of your passengers and other boats are among your responsibilities as operator of the boat. Your boat must be in compliance with USCG safety equipment regulations.

### Before Launching:

- ✓ If pulling from storage, de-winterize the engines, consult your Cobalt dealer if necessary.
- ✓ Install drain plug.
- ✓ Have enough life-saving devices for every person onboard.
- ✓ Verify the amount of fuel in the fuel tanks.
- ✓ Verify the batteries are fully charged.
- ✓ Check all fluid levels. Refer to the propulsion unit operator's manual or consult your Cobalt dealer.
- ✓ Check weather conditions.
- ✓ Be sure the lights, horn, bilge pumps and other electrical equipment are in operating conditions.
- ✓ Be sure the fire extinguisher, signaling devices and other emergency gear are onboard and in proper operating condition.

### Pre-Operation:

- ✓ Test operation of carbon monoxide detectors.
- ✓ Open all seacocks and check for leaks.
- ✓ Check seawater strainers for leaks and accumulation of debris.
- ✓ Check generator fuel/water separator.
- ✓ Open windows, doors and hatches.
- ✓ Check that no fuel, oil or water is leaking or has leaked into the bilge compartment.
- ✓ Check all hoses and connections for leakage and damage.
- ✓ Check that the steering system operates properly.
- ✓ Do not overload your boat.

### Starting Engines

- ✓ Operate bilge blowers for at least four minutes before starting the engines or generator.
- ✓ Attach lanyard to the ignition safety switch and the operator.
- ✓ Move both shift levers to the neutral position.
- ✓ Move both throttle levers to the idle position.
- ✓ Start both engines. Operate the engines at 1000 RPM (gas engines), 1400 RPM (diesel engines) and check if oil pressure is within specified range. Make sure the water pressure gauges start to indicate pressure in 15 seconds or less after starting. If not, shut off the engines and verify the engines are getting cooling water.
- ✓ After engines are warmed up, verify water temperature is within its specified range.

### Casting Off:

- ✓ Allow enough room between the boat and the dock to swing the boat away from the dock.
- ✓ Retrieve all mooring lines and fenders.
- ✓ Proceed slowly and sound a long blast to alert other boaters you are leaving.

### During Operation:

- ✓ Check gauges frequently for signs of abnormal operation.
- ✓ Check for excessive vibration.
- ✓ Monitor your fuel supply.
- ✓ Verify charging of the batteries.

### Returning to Port

- ✓ Come to a stop a short distance from the dock, then proceed slowly.
- ✓ Have your fenders, mooring lines and the crew ready.

## Stopping the Engines

- ✓ Slowly bring the throttle levers to the idle position.
- ✓ Move the shift lever to neutral.
- ✓ Turn the ignition keys to OFF position.

### After Boating:

- ✓ Turn OFF your navigational lights, leave the anchor light ON, if necessary.
- ✓ Check the bilge for gas fumes and water. Operate the blower and bilge pump, if necessary.
- ✓ Fill fuel tanks to prevent moisture due to condensation.
- ✓ To prevent marine growth from accumulating on the hydraulic cylinder shafts, make sure trim tabs are UP and propulsion unit drives are in the full IN position.

- ✓ Lock ignition key switch and remove the ignition keys.
- ✓ Stow and secure all equipment.
- ✓ Pump bilges dry with manual switch.
- ✓ Close all water inlet seacocks.
- ✓ If possible, inspect the hull and propellers for damage.
- ✓ Check for fuel, oil and water leakage.
- ✓ Clean any spills, stains or moisture from the boat. Inspect sea strainers.
- ✓ Turn battery select switches to OFF.
- ✓ Turn breakers on electrical panel to OFF.
- ✓ Remove any food, garbage and wet gear from the boat.
- ✓ Secure lockers, hatches and canvas as equipped.





## FLOAT PLAN

Copy this page and fill out the copy before boating. Leave the filled out copy with a reliable person who can be depended upon to notify the USCG or other rescue organization, should you not return as scheduled. Do not file this plan with the USCG.

Name \_\_\_\_\_ Telephone \_\_\_\_\_

Description of Boat: Type **Performance Cruiser** Color \_\_\_\_\_ Trim \_\_\_\_\_

Registration Number \_\_\_\_\_

Length **36'** Name \_\_\_\_\_ Make **Cobalt**

Other Info. \_\_\_\_\_

Persons Aboard: Name Age Address & Telephone

Name	Age	Address & Telephone
_____	_____	_____
_____	_____	_____
_____	_____	_____

Engine Type: \_\_\_\_\_ HP \_\_\_\_\_

No. of Engines: \_\_\_\_\_ Fuel Capacity: \_\_\_\_\_

Survival Equipment:

PFDs \_\_\_\_\_ Flares \_\_\_\_\_ Mirror \_\_\_\_\_

Smoke Signals \_\_\_\_\_ Flashlight \_\_\_\_\_ Food \_\_\_\_\_

Paddles \_\_\_\_\_ Water \_\_\_\_\_ Anchor \_\_\_\_\_

Raft or Dinghy \_\_\_\_\_ EPIRB \_\_\_\_\_

Radio: Yes \_\_\_\_\_ No \_\_\_\_\_ Type \_\_\_\_\_ Freq \_\_\_\_\_

Destination \_\_\_\_\_ Est. Time of Arrival \_\_\_\_\_

Expect to Return By \_\_\_\_\_

Auto Type \_\_\_\_\_ License No. \_\_\_\_\_ Parked \_\_\_\_\_

If not returned by \_\_\_\_\_ call the Coast Guard, or \_\_\_\_\_

(Local Authority). Coast Guard Telephone Number: \_\_\_\_\_

Local Authority Telephone Number: \_\_\_\_\_

## ALPHABETICAL INDEX

12-Volt Accessory Power Receptacle .....	3-10	Cleaning Agents .....	2-5
AC Electrical .....	4-15	Cleaning Canvas.....	5-6
Accessory .....	3-12	Cleaning Clear Vinyl .....	5-7
Aft Bilge Pump.....	3-11	Cleaning Hull/Deck .....	5-4
Aft Speakers (Optional) .....	3-18	Cleaning Stainless Steel.....	5-6
After Boating:.....	3-5	Clear Vinyl.....	5-7
After Boating:.....	6-2	CO Poisoning.....	3-1
After fueling:.....	3-3	Cobalt Warranty .....	1-3
Air Conditioning/Heating.....	3-17	Cockpit Lights .....	3-11
Air Pump .....	3-16	Cockpit Table.....	3-20
Air/Water Temperature Gauge.....	3-10	Cockpit Tonneau Cover – Optional.....	3-36
Alphabetical Index .....	6-6	Collisions/Leaks .....	2-6
Amenities .....	1-4	Combination GPS/Radar Unit .....	3-13
Anchoring.....	3-33	Combination Port and Starboard Drive Unit Trim Switch .....	3-16
Approaching a Mooring .....	3-28	Compass.....	3-20
Approaching a Slip .....	3-28	Components, Maintenance and Repairs.....	2-5
Arch Antenna and Gain Control .....	3-22	Construction Standards/Certifications.....	1-4
Arch Bimini and Enclosure .....	3-35	Cooling System.....	2-3
Arch Maintenance.....	5-8	Corrosion Protection.....	5-8
Arch Waxing.....	5-8	CorrosionX.....	5-8
Audible/Visual Distress Signals .....	2-8	Crossing Situation.....	2-16
Basic Maneuvering .....	3-29	Dark Stowage Areas.....	5-5
Battery Charger .....	4-18	Dash.....	1-7
Battery Switch Panel .....	3-14	Dash.....	1-8
Battery Switches .....	3-15	DC Electrical .....	4-15
Before Each Use.....	5-2	Deck Occupancy.....	4-6
Before Launching:.....	6-1	Deck Plates/Thru-Hulls.....	4-5
Before Operating.....	1-4	Digital Depth Gauge .....	3-8
Before Starting Checklist.....	3-4	Dimensions .....	4-3
Bilge .....	4-6	Discharge of Oil.....	2-14
Bilge .....	5-6	Discharge/Disposal of Waste .....	2-4
Blower Switch .....	3-11	Distress Signals .....	2-7
Boarding.....	3-4	Docking .....	3-28
Boarding Ladder .....	3-18	Docking Lights .....	3-12
Boat Theory .....	2-3	Doors, Hatches and Stowage.....	4-4
Boating Terminology .....	1-5	Drive Unit Trim .....	3-29
Boating Under the Influence.....	3-2	Drowning.....	2-6
Bow Sun Pad.....	3-18	Drugs/Alcohol .....	2-12
Break-In.....	5-1	During Operation: .....	3-5
Burdened Boats.....	2-16	During Operation: .....	6-1
Cabin Access Door .....	3-18	Education Opportunities .....	2-2
Cabin Distribution Panel .....	4-14	Electrical .....	5-13
Cabin Entertainment System .....	3-17	Electrical System .....	2-3
Cabin Table .....	3-18	Electrical System .....	5-3
Cabinetry.....	5-5	Electronic Control .....	3-16
Canvas .....	1-7	Emergency Considerations .....	2-5
Canvas .....	1-8	Encountering Vessels .....	2-16
Canvas .....	5-6	Engine .....	5-12
Canvas Care .....	5-7	Engine Compartment Lights.....	3-11
Canvas, Curtains and Covers .....	3-35	Engine Hatch .....	3-12
Capacity .....	2-10	Engine Oil Pressure Gauge .....	3-8
Captain's Chair .....	3-19	Engine Synchronizer.....	3-7
Carbon Monoxide Detector .....	3-19	Engine Water Pressure Gauge .....	3-8
Care and Cleaning of Vinyl.....	5-4	Engine Water Temperature Gauge .....	3-8
Carpet .....	5-5	Engine/Propulsion/Cooling System.....	5-3
Casting Off:.....	6-1	Environmental Considerations.....	2-4
Circuit Breaker Panel.....	3-14	Environmental Considerations.....	3-34
Circuit Breakers .....	3-15	Equipment.....	3-16
		Every 100 Hours.....	5-2

# Checklist, Forms and Index

Every 50 Hours.....	5-2	Instrumentation.....	3-6
Excessive Noise.....	2-4	Insurance.....	2-3
Excessive Noise.....	2-14	Interior.....	1-7
Exhaust Diverter.....	3-12	Interior.....	1-8
Exhaust Emissions.....	2-5	Interior/Exterior Care.....	5-4
Exhaust System.....	2-3	Inverter/Battery Charger.....	4-19
Extended Powertrain Warranty.....	1-4	Jump Start Studs.....	3-15
Exterior.....	1-7	Launching.....	3-3
Exterior.....	1-8	Launching Checklist.....	3-3
Features/Construction.....	1-4	Leather Care.....	5-5
Federal, State and Local Regulations.....	2-14	Leaving.....	3-27
Fire.....	2-5	Life Raft.....	2-9
Fire Extinguisher.....	2-2	Life Saving Equipment.....	2-7
Fire Suppression Equipment.....	4-20	Lifesaving Devices.....	2-2
Fire/Explosion.....	3-1	Lifting the Boat.....	5-9
First Time Operation.....	3-2	Light Structures.....	2-20
Fishery Resources.....	2-5	Lighthouses.....	2-20
Float Plan.....	6-5	Load Distribution.....	3-29
Flooding/Swamping.....	2-6	Loading.....	2-10
Foreign Species.....	2-5	Loading.....	3-4
Forward Bilge Pump.....	3-11	Logic Tree Chart.....	5-11
Freezing Temperatures.....	3-34	Lowering.....	3-33
Fresh Water.....	4-10	Lubrication System.....	2-3
Fresh Water.....	5-3	Macerator Discharge Pump (Optional).....	4-9
Fuel.....	4-7	Machinery Arrangement.....	4-1
Fuel Level Gauge.....	3-7	Main Switch Panel.....	3-11
Fuel Log.....	6-4	Maintenance Schedule.....	5-1
Fuel System.....	2-3	Marine Growth.....	5-9
Fuel System.....	5-3	Marine Sanitation.....	2-14
Fuel/Spillage.....	2-4	Marine Toilet.....	4-8
Fueling.....	3-2	MARPOL Treaty.....	2-4
FWMS.....	2-19	Medical Emergency.....	2-6
Galvanic.....	5-9	Meeting Head-On.....	2-17
Gauges.....	3-7	Microwave.....	3-21
General Safety.....	2-10	Minor Lights.....	2-20
Generator.....	4-18	Monthly.....	5-2
Generator Control Panel.....	3-13	Mooring Cover – Optional.....	3-37
Getting Underway.....	3-4	Nautical Terms.....	1-9
Gray Water.....	5-3	Navigation.....	2-15
Gray Water (Optional) - Sink and Shower Drain Water Only.....	4-12	Navigation Lights.....	2-1
Grounding.....	2-6	Navigational Aids.....	2-17
Handholds.....	2-10	Navigational Lights.....	3-11
Handling Dock and Mooring Lines.....	3-23	On the Water.....	3-3
High Speed Operation.....	3-32	Operating Conditions.....	2-10
Horn.....	3-10	Operation Checklist.....	2-4
Horn or Whistle.....	2-1	Operation Failure.....	2-6
Hot Water Tank.....	3-20	Operation Quick Reference.....	6-1
Hour Meter.....	3-9	Optional Equipment.....	1-8
Hull/Deck.....	5-4	Other Areas.....	5-8
Hull/Deck Care.....	5-4	Overtaking.....	2-17
Icemaker.....	3-21	Owner Responsibility/ Warranty Procedure.....	1-4
If You Sell Your Cobalt.....	1-4	Owner/Operator Responsibilities.....	2-1
Ignition Breakers.....	3-10	Paints.....	2-5
Ignition Safety Switch.....	3-10	Passengers.....	2-12
Ignition Switch Panel.....	3-9	Personal Flotation Devices.....	2-7
Ignition Switches.....	3-10	Piping.....	4-10
Indicators.....	3-15	Plumbing.....	5-13
Individual Drive Unit Trim Switches.....	3-16	Pre-Operation:.....	3-4
Inside the Bulkhead.....	5-8	Pre-Operation:.....	6-1
		Precautions.....	3-1

Preventive Steps.....	5-6	Stereo/Video .....	1-8
Privileged Boats.....	2-16	Stopping Diesel Engines .....	3-26
Publications.....	1-8	Stopping Gas Engine .....	3-26
Qualified Boat Operators .....	2-14	Stopping the Engines .....	6-2
Quarterly .....	5-3	Storage Cradle.....	5-9
Radar Panel.....	3-13	Storage/Winterization .....	5-10
Radar Reflectors.....	2-9	Storms.....	2-6
Radio Communication .....	2-7	Stove .....	3-21
Range Lights.....	2-20	Structure/Safety/Performance .....	1-7
Raw Water .....	4-13	Structure/Safety/Performance .....	1-8
Re-activating the Boat After Storage.....	5-10	Sun Lounge .....	3-22
Recommended Safety Equipment .....	2-2	Symbols .....	1-12
Recommended Spare Parts.....	2-2	Table of Contents .....	1-2
Refrigerator/Freezer.....	3-21	Tachometer .....	3-7
Registration/Documentation .....	2-1	Teak Wood .....	5-7
Remote Control System .....	2-3	Techniques.....	3-28
Remote Controls.....	3-16	Television .....	3-22
Rendering Assistance.....	2-15	Tie Down Locations .....	4-19
Reporting Accidents .....	2-14	Topside.....	5-8
Required Safety Equipment .....	2-1	Towing.....	3-34
Returning .....	3-27	Trim .....	3-29
Returning to Port .....	6-1	Trim Tab Switches.....	3-16
Rules of the Road/Sound Signals .....	2-15	Trim Tabs.....	3-30
Safety .....	2-9	Troubleshooting.....	5-11
Safety While Boating .....	2-14	Twin Engine Operation .....	3-31
Salt Water .....	3-34	Uniform State Regulatory Markers.....	2-18
Salt Water .....	5-9	Unscheduled Maintenance.....	5-3
Scheduled Maintenance and Service .....	5-1	Upholstery.....	5-4
Sea Anchors .....	2-9	Useful Information.....	6-9
Search Light.....	3-13	Using Lifting Eyes .....	5-9
Seating.....	2-10	Using Lifting Slings .....	5-9
Seaworthiness Inspection.....	2-4	Using Only Shore 1 Power Cord .....	4-16
Serial Number Locations .....	1-4	VacuFlush Status Panel .....	4-9
Service Log.....	6-3	VacuFlush®.....	4-9
Setting .....	3-33	Ventilation .....	2-12
Shift/Throttle Control Panel .....	3-15	Ventilation System .....	2-3
Shifting/Running .....	3-25	VHF/FM Radio.....	3-10
Shipshape .....	3-4	Visibility .....	2-11
Shore Power .....	4-15	Visual Distress Signals.....	2-2
Shore Power Connection.....	4-16	Voltage Relay.....	3-15
Shower .....	3-21	Voltmeter.....	3-8
Signal Words/Definitions.....	2-9	Wake/Wash .....	2-5
Skill/Experience .....	2-11	Wake/Wash .....	2-14
Snap Fasteners.....	5-7	Warning Labels.....	1-6
Solid Waste Disposal.....	2-14	Warning Markers .....	2-21
Special Cleaning Problems .....	5-6	Warranty Service Requirements .....	1-4
Special Situations .....	2-17	Water Rescue (Man Overboard) .....	2-6
Specifications.....	1-5	Water System .....	5-3
Speedometer .....	3-7	Watersports Safety .....	2-15
Stainless Steel and Chrome.....	5-6	Weather/Seas .....	2-11
Standard Equipment.....	1-7	Weighing .....	3-34
Starting Diesel Engines.....	3-24	Welcome .....	1-1
Starting Engines .....	6-1	When fueling:.....	3-2
Starting Gas Engines .....	3-23	Whistle/Horn Signals .....	2-16
Starting/Shifting/Steering/Stopping .....	3-23	Windlass Breaker.....	3-15
Steering.....	3-25	Windlass Control.....	3-10
Steering System .....	2-3	Windshield .....	5-5
Stereo Remote Control.....	3-13	Wiper.....	3-12
Stereo/Video .....	1-7	Zippers .....	5-7

## USEFUL INFORMATION

Store this information in a safe place other than on your boat.

Owner \_\_\_\_\_

Home Port \_\_\_\_\_

Boat Name \_\_\_\_\_

Selling Dealer \_\_\_\_\_

Port Ignition Key Number \_\_\_\_\_ Starboard Ignition Key Number \_\_\_\_\_

Cabin Key Number \_\_\_\_\_

Registration Number \_\_\_\_\_ State \_\_\_\_\_

Hull Serial Number \_\_\_\_\_ Warranty Registration Date \_\_\_\_\_

Engine Make and Model Number \_\_\_\_\_

Port Engine Serial Number \_\_\_\_\_ Starboard Engine Serial Number \_\_\_\_\_

Port Drive Serial Number \_\_\_\_\_ Starboard Drive Serial Number \_\_\_\_\_

Propeller Size \_\_\_\_\_

Generator Make and Model Number \_\_\_\_\_ Serial Number \_\_\_\_\_

VHF Radio Make and Model Number \_\_\_\_\_ Serial Number \_\_\_\_\_

GPS Make and Model Number \_\_\_\_\_ Serial Number \_\_\_\_\_

Radar Make and Model Number \_\_\_\_\_ Serial Number \_\_\_\_\_

DVD Make and Model Number \_\_\_\_\_ Serial Number \_\_\_\_\_

Stereo Make and Model Number \_\_\_\_\_ Serial Number \_\_\_\_\_

TV, Cabin Make and Model Number \_\_\_\_\_ Serial Number \_\_\_\_\_

TV, Mid-berth Make and Model Number \_\_\_\_\_ Serial Number \_\_\_\_\_

VCR Make and Model Number \_\_\_\_\_ Serial Number \_\_\_\_\_

Subwoofer Make and Model Number \_\_\_\_\_ Serial Number \_\_\_\_\_







Cobalt Boats  
P.O. Box 29  
Neodesha, KS 66757  
Phone 800-468-5764 • Fax 316-325-2361  
[www.cobaltboats.com](http://www.cobaltboats.com)