

COBALT

Owner's Manual



OWNER INFORMATION

COBALT BOATS - OWNER'S MANUAL

Owner's Name _____

Address _____

City _____ State _____ Zip _____

Hm. Phone _____ Wk Phone _____

Cobalt Model _____ **Model Year** _____ **Hull Serial No.** _____

Engine _____ Engine Serial No. _____

Drive _____ Drive serial No. _____

Dealership _____

Address _____

City _____ State _____ Zip _____

Main Phone _____ Service Phone _____

Sales Contact _____ Service Contact _____

Extended Warranty Contract No. _____

Marina/Storage _____

Address _____

City _____ State _____ Zip _____

Phone _____ Contact Name _____



COBALT BOATS

COBALT BOATS - OWNER'S MANUAL

Dear New Cobalt Owner,

From all of us at the factory and from your Cobalt Dealer, thank you for purchasing a Cobalt. We greatly appreciate your business and look forward to a long and enjoyable relationship with you as part of the Cobalt family.

This manual is designed to help you maximize the enjoyment of your Cobalt boat, and to acquaint you with proper operation, care, storage, and maintenance of your investment.

Even if you're a seasoned boater and have previously owned a Cobalt, I recommend you take time to read through this Owner's manual. As you read this manual, please remember that "common sense" and "courtesy" are the most valuable traits you can have to fully enjoy safe boating. It is also to your personal advantage to become well acquainted with the rules and general "know how" of boating.

For service and for assistance contact your Cobalt dealer. The dealership staff will be happy to answer questions concerning maintenance, warranty, or any other operational questions you may have about your Cobalt.

All the best in boating,

A handwritten signature in black ink, appearing to read "Paul St. Clair". The signature is fluid and cursive, with a long horizontal stroke extending to the right.

Paul St. Clair, Chairman and C.E.O.

MARINE SAFETY STANDARDS

WE WISH YOU SAFE AND HAPPY BOATING!

The American Boat and Yacht Council, Inc. is an independent organization dedicated to developing and maintaining the highest level of marine equipment safety standards for U.S. boat manufacturers. Working closely with the U.S. Coast Guard and other authorities, the A.B.Y.C. reviews marine equipment and systems, including electrical systems, ventilation, steering, flotation, load capacity, fuel systems, and others that may have impact on your safety.

The National Marine Manufacturers Association is an independent organization involved in a wide range of activities aimed toward the promotion and improvement of all aspects of boating. Members include manufacturers of boats, engines, and marine equipment of all types.

One division of the N.M.M.A. provides an inspection and certification program to members. Inspections are performed to the rigid and detailed standards of the A.B.Y.C. and certification requires compliance with all applicable standards and recommendations.

Every Cobalt is built to meet or exceed all applicable standards of these organizations at the time of manufacture. Each model is inspected and certified prior to introduction, and periodic inspections of the entire model line are conducted in-plant to insure continued compliance.



TABLE OF CONTENTS

COBALT BOATS - OWNER'S MANUAL

WELCOME	i
WE WISH YOU SAFE AND HAPPY BOATING	ii
WARRANTY PROCEDURE AND OWNER RESPONSIBILITY ..	vii
Cobalt Warranty	vii
Owner Responsibility/Warranty Procedure	viii
Extended Powertrain Warranty	viii
If You Sell Your Cobalt	viii
BOATING TERMINOLOGY	ix
Warning Labels	x
Symbols	xii
I - RESPONSIBILITIES AND SAFETY	
Owner/Operator Responsibilities	1
Registration/Documentation	2
Required Safety Equipment	2
Recommended Equipment	6
Recommended Spare Parts	6
Education Opportunities	7
Insurance	7
Seaworthiness Inspection	7
Environmental Considerations	8
MARPOL Treaty	8
California Air Resource Board (CARD) Level	8
Emergency Considerations	9
II - GENERAL SAFETY	
Qualified Boat Operators	19
Safety While Boating	19
III - NAVIGATION	
“Rules of the Road”/Sound Signals	23
Encountering Vessels	23
Navigational Aids	26
Warning Markers	31
IV - OPERATING INFORMATION	
Precautions	33
Instrumentation	33
Fueling	34
Boarding	36



Loading36
Launching36
On the Water37
Getting Underway37
Steering38
Basic Maneuvering39
Water Ski Towing44
Boating At Night44
High Speed Operation45
Anchoring46
Towing47
Stopping Engines47
Docking/Lifting/Storage/Trailer Your Cobalt48
Environmental Considerations49

V - INTERIOR/EXTERIOR CARE

Vinyl Interior and Upholstery Care51
Care and Cleaning of Vinyl51
Dark Storage Areas52
Leather Care53
Vacuuming53
Carpet Care53
Fiberglass Finish Care53
Stainless Steel Trim and Hardware Care54
CorrosionX54

VI - CANVAS

Erecting Canopy Top57
Side Curtains and Stern Curtain – Optional57
Bimini Top – Optional58
Bimini Enclosure – 226/246/262/263/293 (Optional)60
Bow Tonneau Cover – Optional (Bowriders Only)61
Cockpit Tonneau Cover – Optional61
Mooring Covers – Optional61
Stowage of the Canopy – 226/24662
Cobalt Canvas Care62
Other Canvas Components64

VII - TECHNICAL INFORMATION

Engine Operation/Maintenance/Serviceing65
The Break-In Period65
Winterizing and Off-Season Storage65
Fuel Requirements67
Circuit Breakers67
Fuses67
Lighting/Bulb Replacement68
Wet Locker Draining68
Battery Connection(s)68
Stereo Equipment69
Marine Toilet (Head) and Optional Macerator69



VIII - TROUBLESHOOTING

Ignition Safety Switch73
Air Horn – 262/263/29373
Starter Won't Crank Engine74
Engines Runs Erratically74
Engines Vibrates74
Engine Runs but Boat Makes Little or No Progress74
Performance Loss75
Fuel Injection Engines75

MODEL SPECIFIC INFORMATION

Model 200200.1
Model 220220.1
Model 226226.1
Model 240240.1
Model 240SDSD.1
Model 246246.1
Model 262262.1
Model 263263.1
Model 282282.1
Model 293293.1

SERVICE LOG

.....A





WARRANTY PROCEDURE AND OWNER RESPONSIBILITY

COBALT BOATS - OWNER'S MANUAL

COBALT WARRANTY

Ten-year limited transferable warranty on hull and deck structure, two-year limited transferable warranty on other component parts.

Cobalt Boats warrants the hull and deck, including floor, stringers, motor mounts, transom and deck/hull joints, of each new Cobalt boat to be free from structural defects in material and workmanship under normal recommended use for a period of ten (10) years from the date of delivery to the original retail purchaser.

Cobalt Boats warrants the gelcoat finish, upholstery, components not having their own warranty and all components manufactured by Cobalt Boats, other than the hull and deck, of each new Cobalt boat to be free from structural defects in material and workmanship under normal recommended use for a period of two (2) years from the date of delivery to the original retail purchaser.

This warranty does not apply to (1) engines, outdrives, controls, batteries, or other equipment or accessories which are separately warranted by the manufacturers thereof (appropriate adjustments therefore being provided by the respective manufacturer); (2) engines or accessories installed by persons or parties other than Cobalt Boats; (3) windshield leakage, upholstery damage, carpet damage and gelcoat damage; and (4) any Cobalt boat which has been altered, subject to misuse, negligence or accident, or used for racing or commercial purposes.

The rights and benefits granted under this warranty to the original retail purchaser of a new Cobalt boat shall extend to any owner of such Cobalt boat during the applicable warranty period, commencing with the date of delivery to the original retail purchaser, as set forth herein, provided this warranty is validated by such owner, as set forth herein. In no event shall the owner of any Cobalt boat, covered by this warranty, have any rights or benefits under this warranty which are greater than the rights and benefits which would have been available under this warranty to the original retail purchaser of such Cobalt boat had the original retail purchaser remained the owner of such Cobalt boat.

Cobalt Boats shall not be liable for special or consequential damages, such as, but not limited to, damages for cost of replacement goods, or damages for claims of third parties against the purchaser, or damages for loss of profits.

To validate this warranty, the original retail purchaser must return the warranty registration card to Cobalt Boats within ten (10) days after purchase of any new Cobalt boat covered by this warranty, and any subsequent owner of a Cobalt boat during the applicable warranty period must give written notice of acquisition of a Cobalt boat to Cobalt Boats within ten (10) days after such purchase.

Notification of any warranty claim, arising within the applicable warranty period, as set forth above, must be made in writing by the owner of the Cobalt boat or by an authorized Cobalt Boats dealer to Cobalt Boats within thirty (30) days after the discovery of the alleged basis for any warranty claim.



During the applicable warranty period, as set forth above, warranty repairs shall be made without charge by an authorized Cobalt Boats dealer or, at the option of Cobalt Boats, by Cobalt Boats at its plant in Neodesha, Kansas. All warranty repairs shall be subject to the authorization of factory-trained personnel of Cobalt Boats, whose decision will be final. Transportation to and from an authorized Cobalt Boats dealer, and/or to and from the Cobalt Boats plant in Neodesha, Kansas, for warranty repairs, shall be at the owners' expense.

In no event shall the liability of Cobalt Boats under this warranty exceed the purchase price of the specific item or items to which this warranty relates.

This warranty constitutes the only express warranty covering a new Cobalt boat. Any implied warranty, which may be determined to pertain to any component of a new Cobalt boat, is limited to ten (10) years on the hull and deck structure, and limited to two (2) years on all other component parts covered by the express warranty as set forth above, except in those states which have other limitations on the duration of an implied warranty.

This warranty gives you specific rights and remedies. In addition, you may also have other rights and remedies which vary from state to state.

OWNER RESPONSIBILITY/WARRANTY PROCEDURE

BEFORE OPERATING

Before operating your new Cobalt, it is necessary you read and understand this manual. Also, take the time to read the other manuals supplied to you by your dealer.

WARRANTY SERVICE REQUIREMENTS

All Cobalt warranty service must be completed by an authorized Cobalt dealer. If you are not able to return your boat to your selling dealership, you must contact him so he may assist you in coordinating the warranty repairs. Any claims against Cobalt Boats without prior approval from Cobalt Boats on repairs completed by a non-authorized dealership may be denied.

EXTENDED POWERTRAIN WARRANTY

Your Cobalt warranty includes an Extended Limited Powertrain Warranty. Your dealer submitted the necessary forms to implement this warranty. Please read the extended warranty manual supplied to you by Passport Premiere.

It is important you have your Cobalt serviced per the engine manufacturer's recommended instructions. You must keep, in your possession, records of all service performed should the extended powertrain warranty be needed. This is to prove the required maintenance has been performed.

If you have any questions referencing your Extended Powertrain Warranty, please contact your Cobalt dealer.

IF YOU SELL YOUR COBALT

Your warranties are transferable. If you sell your Cobalt to anyone other than an authorized Cobalt dealer, please call Cobalt Boats for the appropriate warranty transfer information (800-468-5764 or 620-325-2653). If the proper transfer procedures are not followed, future warranty may be denied.



BOATING TERMINOLOGY

COBALT BOATS - OWNER'S MANUAL

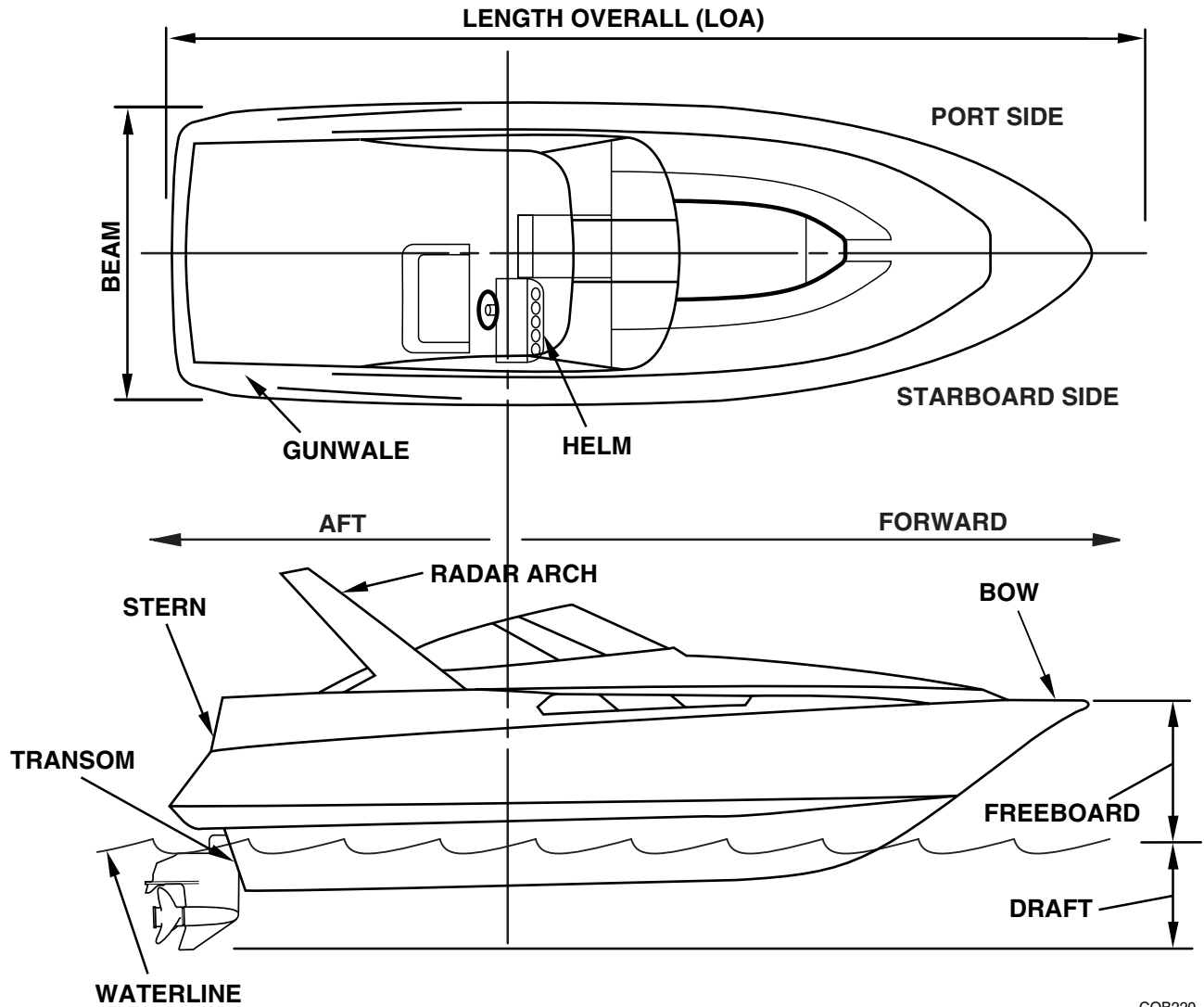

COB220

* An easy way to remember PORT side from STARBOARD side is “PORT” and “LEFT” both have four letters.



WARNING LABELS

Warning labels must remain legible. If you suspect a label is missing or becomes damaged, please contact your Cobalt dealer for immediate replacement.



Your Cobalt has several warning labels displayed to point out safety hazards. The areas are as follows:

 **WARNING**
 PROPELLER LOCATED BEHIND THIS BOAT.
 CONTACT MAY CAUSE SEVERE INJURY OR FATALITY.
 DO NOT APPROACH OR USE LADDER AND PLATFORM
 WHEN THE ENGINE IS RUNNING.

BOARDING LADDER/SWIM PLATFORM

 **DANGER**
 CARBON MONOXIDE IS COLORLESS, ODORLESS AN
 DANGEROUS. ALL GASOLINE POWERED ENGINES
 AND GENERATORS EXHAUST CARBON MONOXIDE
 (CO). DIRECT AND PROLONGED EXPOSURE TO CO
 WILL CAUSE BRAIN DAMAGE OR DEATH. SIGNS OF
 EXPOSURE TO CO INCLUDE NAUSEA, DIZZINESS AND
 DROWSINESS.
 Keep Cabin and Cockpit Areas Well Ventilated. Avoid
 Blockage of Exhaust Outlets.
 See Owner's Manual for More Details.

CARBON MONOXIDE

 **WARNING** 
 LEAKING FUEL IS A FIRE AND
 EXPLOSION HAZARD. INSPECT SYSTEM
 REGULARLY. EXAMINE FUEL SYSTEM
 FOR LEAKS OR CORROSION AT LEAST
 ANNUALLY.
 © NMMA 1990/ NO.200

ENGINE FLAME ARRESTOR

WARNING - GASOLINE VAPORS CAN EXPLODE.
 BEFORE STARTING ENGINE:
 • CHECK ENGINE COMPARTMENT FOR GASOLINE OR VAPORS.
 • OPERATE BLOWER FOR 4 MINUTES.
 • VERIFY BLOWER OPERATION.
 • RUN BLOWER BELOW CRUISING SPEED.

DASHBOARD

WARNING!
 SECURE DOOR WHEN CRUISING
 DO NOT SIT, STAND, OR PLACE
 HEAVY OBJECTS ON DOOR.
 KEEP CABIN DOOR CLOSED WHEN
 ENGINES OR GENERATOR ARE RUNNING.
 DO NOT USE
 CAUSTIC MATERIALS TO CLEAN.
 WASH WITH MILD SOAP AND WATER.

CABIN DOOR



⚠ WARNING

DO NOT OCCUPY EXTENDED SWIM PLATFORM WHILE ENGINE IS RUNNING OR ENGAGED. PROPELLER CONTACT MAY CAUSE SEVERE INJURY OR FATALITY. ALL GASOLINE POWERED ENGINES PRODUCE CARBON MONOXIDE (CO). CO IS COLORLESS, ODORLESS, AND DANGEROUS. DIRECT AND PROLONGED EXPOSURE TO CO WILL CAUSE BRAIN DAMAGE OR DEATH.

EXTENDED SWIM PLATFORM

⚠ WARNING

EXTENDED SWIM PLATFORM MUST BE ATTACHED WHILE BOAT IS IN USE TO AVOID POSSIBLE INJURY OR DROWNING. SWIM LADDER IS ATTACHED TO THE PLATFORM.

REMOVABLE FEATURE IS FOR BOAT STORAGE PURPOSES ONLY.

REMOTE TILT SWITCH

WARNING

AVOID OBSTRUCTION OF NAVIGATION LIGHTS AND POSSIBLE COLLISION. REMOVE CANVAS BEFORE USING NAVIGATION OR ANCHOR LIGHTS.

NAVIGATION LIGHTS

⚠ WARNING

Keep hands and feet away from drive unit when tilting.

COBALT CHECK LIST

For maximum enjoyment and safety, check each of these items BEFORE you start your engine:

- DRAIN PLUG (Securely in place?)
- LIFE-SAVING DEVICES (One for every person on board?)
- STEERING SYSTEM (Working smoothly and properly?)
- FUEL SYSTEM (Adequate fuel? Leaks? Fumes?)
- BATTERY (Fully charged? Proper water level?)
- ENGINE (In neutral?)
- CAPACITY PLATE (Are you overloaded?)
- WEATHER CONDITIONS (Safe to go out?)
- ELECTRICAL EQUIPMENT (Lights, horn, pump, etc.?)
- EMERGENCY GEAR (Fire Extinguisher, Bailer, Paddle, Anchor and Line, Signalling Device, Tool Kit, Etc.?)

RECOMMENDED SAFETY RULES

- REMAIN SEATED WHILE UNDERWAY.
- AVOID USING REAR PAD OR SUNDECK WHILE ENGINE IS RUNNING.
- DO NOT USE BOARDING LADDER WHILE ENGINE IS RUNNING.
- TURN OFF ENGINE AND ALL ELECTRICAL SYSTEMS WHILE RE-FUELING.
- TURN OFF ENGINE(S) WHEN SWIMMERS ARE NEAR BOAT.

WINDSHIELD WING, DRIVER'S SIDE COBALT CHECK LIST



SYMBOLS

Throughout this manual specific precautions and symbols identify safety related information.

The Safety Alert Symbol means ATTENTION! BECOME ALERT! YOUR SAFETY IS INVOLVED!



DANGER



WARNING



CAUTION



NOTE



DANGER

INDICATES THE PRESENCE OF A HAZARD WHICH WILL CAUSE SEVERE INJURY, DEATH OR SUBSTANTIAL PROPERTY DAMAGE.



WARNING

INDICATES THE PRESENCE OF A HAZARD WHICH CAN CAUSE SEVERE INJURY, DEATH OR SUBSTANTIAL PROPERTY DAMAGE.



CAUTION

INDICATES THE PRESENCE OF A HAZARD WHICH WILL OR CAN CAUSE MINOR OR MODERATE PERSONAL INJURY OR PROPERTY DAMAGE.



NOTE

Indicates installation, operation or maintenance information which is important but not hazard-related.

The precautions listed in this manual and on your Cobalt boat are not all-inclusive. If a procedure, method, tool, or part is not specifically recommended, you must satisfy yourself that it is safe for you and others, and the boat will not be damaged or made unsafe as a result of your decision. REMEMBER--USE COMMON SENSE WHEN OPERATING YOUR BOAT!



OWNER/OPERATOR RESPONSIBILITIES

Your safety, the safety of your passengers, and other boaters are among your responsibilities as operator of this boat. Your boat must be in compliance with U.S. Coast Guard (USCG) safety equipment regulations. You should know how to react correctly to adverse weather conditions, have good navigation skills, and follow the “Rules of the Road” as defined by the USCG and state/county/local regulations.

At the time of delivery, the owner/operator is responsible for:

- Understanding warranty terms and conditions of both the propulsion units and boat.
- Obtaining insurance.
- Examining boat to ensure proper operation of all systems.

Before operating the boat, the owner/operator is responsible for:

- Obtaining state registration of the boat.
- Providing the proper USCG required safety equipment.
- Following proper break-in procedure for the propulsion units.
- Understanding safety information and proper operating procedures within this manual.

While operating the boat, the owner/operator is responsible for:

- Knowing that all safety equipment and personal flotation devices are in good condition and suitable for your boat and passenger load.
- Having at least one other passenger who is capable of handling the boat in an emergency.
- Following safe operating practices and the “Rules of the Road.”
- Understanding proper maintenance and knowledge of the boat’s operating systems.
- Providing safety training for the passengers.
- Avoiding use of alcohol and other drugs.
- Providing assistance to other boaters.



REGISTRATION/DOCUMENTATION

The USCG requires that all power boats operated on the navigable waters of the U. S. must be registered in the state of main use; also, many states require registration in that state whenever boating on waters within their state boundary. Contact your state boating authorities (and neighboring states) for registration information on boats and trailers. Your dealer can supply you with the appropriate forms.

REQUIRED SAFETY EQUIPMENT

The Federal Boat Safety Act of 1971 (FBSA/71) established minimum safety standards for boats and associated equipment, specified by the USCG. In addition, the ABYC and the NMMA work with boat builders to develop voluntary standards that exceed base requirements.

The included safety equipment on your Cobalt meets or exceeds the standards of the USCG, ABYC and the NMMA. Some required safety equipment such as personal flotation devices are not included with your Cobalt boat. Your Cobalt dealer can help you choose the appropriate equipment.



NOTE

Many states' equipment requirements go beyond USCG requirements. Contact your state boating office for further information.

Equipment requirements for coastal and inland waters differ. Check with local authorities or the USCG for further information about coastal water requirements.

MINIMUM REQUIRED SAFETY EQUIPMENT			
EQUIPMENT	CLASS 1 4.8 to less than 7.9 m (16 to less than 26 ft.)	CLASS 2 7.9 to less than 12.2 m (26 to less than 40 ft.)	CLASS 3 12.2 to not more than 19.8 m (40 to not more than 65 ft.)
PERSONAL FLOTATION DEVICES (PFDs)	One approved Type I, II, III or V (if used according to Coast Guard requirements) device aboard for each person on board or being towed on water skis, etc.; and, in addition, one throwable Type IV device.		
FIRE EXTINGUISHER (Must say Coast Guard Approved.)	At least one B-I type approved hand portable fire extinguisher (Not required on outboard motorboats less than 26 feet in length and not carrying passengers for hire if the construction of such motorboats will not permit entrapment of explosive or flammable gasses or vapors and if fuel tanks are not permanently installed.)	At least two B-I type approved portable fire extinguishers; OR at least one B-II type approved portable fire extinguisher.	At least three B-I type approved portable fire extinguishers; OR at least one B-I type plus one B-II type approved portable fire extinguisher.
DAY AND NIGHT VISUAL DISTRESS SIGNALS	Orange flag with black square-and-disk (day); and an S-O-S electric light (night); or three orange smoke signals, hand held or floating (day); or three red flares of hand held, meteor, or parachute type (day/night). Required only on coastal waters, the Great Lakes, territorial seas, and those waters connected directly to them, up to a point where a body of water is less than two miles wide.		
WHISTLE/HORN, BELL	Every vessel less than 12 meters (39.4 ft.) in length must carry an efficient sound producing device.	Every vessel 12 meters (39.4 ft.) but less than 20 meters (65.6 ft.) in length must carry a whistle or horn and a bell. The whistle or horn must be audible for 1/2 nautical mile. The mouth of the bell must be at least 200 mm (7.87 inches) in diameter.	

KC-0081.3



PERSONAL FLOTATION DEVICES

All boats must carry one USCG approved Type I, II, or III, wearable, personal flotation device, of the proper size, for each person on board.

All boats over 4.8 m (16 ft) in length must carry one USCG approved Type IV throwable lifesaving device, such as a ring buoy or buoyant cushion. To meet requirements, each lifesaving device must have a currently legible USCG approval stamp permanently affixed.

The United States Coast Guard's Life Jacket Rule requires all children under the age of 13 years to wear Coast Guard approved life jackets, while aboard recreational vessels underway, except when the children are below decks or in an enclosed cabin. This Rule affects only those States which have not established requirements, by statute or rule, for children to wear life jackets. For the remaining states, the rule recognizes and adopts the existing state regulation even if it is less stringent. The penalties for a boat operator who fails to have all children under this age wear a life jacket, are similar to those for failing to have life jackets on board. Know your state's laws and its requirements.

There are four types of PFDs to wear and one type used for throwing in emergency situations.

Type I Life Preserver: Most buoyant PFDs are effective on all waters, especially open, rough water.

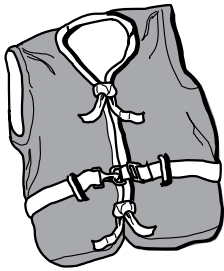

TYPE I
LIFE PRESERVERS
KC-0041

Type II Buoyant Vest: Good for calm water near shore on most inland waters where quick rescue is likely.

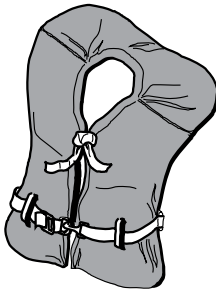

TYPE II
BUOYANT VESTS
KC-0051

Type III Flotation Aid: Good for most inland water applications where quick rescue is likely. Comes in various styles and some are designed for water sport activities.



TYPE III
FLOTATION AIDS
KC-0042



TYPE IV
THROWABLE DEVICES
KC-0071

Type IV Throwable Device: Intended for heavy traffic inland waters where help is available. Designed to be thrown to a person in the water and should never be worn.

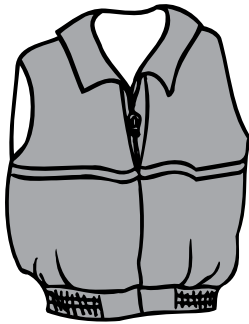

TYPE V HYBRID PFD
MUST BE WORN
WHEN UNDERWAY
KC-0043

Type V Hybrid PFD: Inflatable design for special use activities and may be used instead of a Type I, II, or III PFD if used in accordance with the approval conditions on the label and if worn when the boat is underway. Some Type V PFDs provide increased protection against hypothermia.



NOTE

- *A Type V PFD must be worn to be counted toward the minimum carriage requirements.*
- *Special PFDs are available for skiing and other water sports. These PFDs are constructed with materials suitable for high impact falls.*

PFDs are intended to help save lives. The operator should set an example by wearing one. Wear a PFD whenever boating. It is especially important that children and non-swimmers wear a PFD at all times. Make certain all passengers know how to put on and properly adjust their PFDs. Also, selecting the proper type PFD for your kind of outing helps ensure your time on the water can be the safest possible.

At the beginning of each season, check PFDs for damage and test for proper flotation. Refer to the PFD manufacturer's information.

Your Cobalt dealer can help you select appropriate PFDs and throwable lifesaving devices for your area.

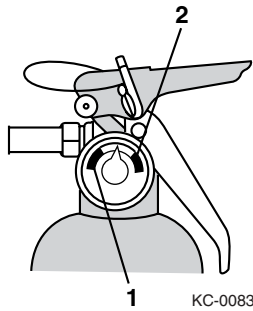

FIRE EXTINGUISHER

All inboard/outboard boats must carry an appropriate portable marine type fire extinguisher in operable condition and accessible location.

The USCG and other law enforcement agency requirements for fire extinguishers are only the minimum needed. Remember, install extra extinguishers where they might be needed such as the galley and engine compartment. Inspect extinguishers on a regular basis.

1. Recharge
2. Overcharge

VISUAL DISTRESS SIGNALS

Federal law also requires boats 4.8 m (16 ft) and longer to carry day and night visual distress signals when operating on coastal waters, the Great Lakes, territorial seas or those waters directly connected to them, up to a point where the body of water is less than two miles wide. Carry several types of signaling devices to handle a variety of conditions. Have enough signals on board to last three days.



NOTE

Some pyrotechnics are restricted from use on certain bodies of water, so check with local authorities.

Your Cobalt dealer can help you select appropriate visual distress signals for your area.

HORN OR WHISTLE

All boats over 16 ft in length must be equipped with an operable horn or whistle, audible from one mile.



RECOMMENDED EQUIPMENT



In spite of all efforts to the contrary, problems or mishaps sometime occur while boating. Stock these items listed below on your boat to help make unexpected events more manageable.

- Anchor and anchor line
- Local charts and compass
- First aid kit and manual
- Distress signals (flag for daytime, flares for darkness)
- Flashlight and spare batteries
- Portable radio and spare batteries
- Cellular phone
- Mooring lines and fenders
- Binoculars
- Emergency Position Indicating Radio Beacon (EPIRB)
- Boat Hook
- Sun glasses and sun block lotion
- Bailing device (bucket, hand pump)
- Combination oar/boat hook
- Lubricant
- Tool kit
- Spare propeller, nut and washer
- Spare fuses and bulbs
- Tow line
- Parallel ruler and dividers
- Spare keys
- Spare fuel
- Food and water
- Auxiliary starting battery

RECOMMENDED SPARE PARTS

The following list contains common spare parts you should carry onboard. Review all the equipment on your boat. Be sure to have spare parts available to maintain and make minor repairs if necessary. Refer to all operator's manuals in your owner's packet for the manufacturer's recommended spare parts.

- Extra lanyard for ignition safety switch
- Engine and generator oil
- Hydraulic fluid for the steering system and trim system
- Extra ignition keys
- Tape, tie straps and rope
- Light bulbs and fuses
- Propeller with attaching hardware



EDUCATION OPPORTUNITIES

Boat smart from the start, take a boating safety course and get a free vessel safety check annually for your boat. For more information, contact: United States Coast Guard Auxiliary, 800-368-5647, www.cgaux.org; United States Power Squadrons, 888-FOR-USPS, www.usps.org.

Most boaters can enhance their enjoyment of boating experiences through increased knowledge of safe operation, navigation and regulation of pleasure boats. The following is a list of some of the agencies and organizations that offer Water Safety, First Aid and CPR courses or information. To find boating safety courses in your area, call your state's local boating agency or the USCG boating safety courseline at 1-800-336-2628 (1-800-245-2628 in Virginia).

- American Red Cross
- U.S. Coast Guard Auxiliary
- U.S. Power Squadrons
- State Boating Offices
- Canadian Power and Sail Squadrons
- Yacht Clubs

INSURANCE

You must get insurance before operating your new boat. Insurance for loss by fire, theft or other causes, or liability protection against accidents is a must for responsible boaters. The boat owner is legally responsible for any damage or injury caused when the owner, or someone else operating the boat, is involved in an accident. Many states have laws detailing minimum insurance needs. Your insurance agent or your Cobalt dealer may be able to supply you with more information.

SEAWORTHINESS INSPECTION

The following checks are essential to safe boating and must be performed before starting the engine(s). Get into the habit of performing these checks in the same order each time so that it becomes routine.

- Check the weather report, wind and water conditions.
- Check that required safety equipment is onboard.
- Check that fire extinguisher(s) is fully charged.
- Check that bilge drain plug is properly installed.
- Check that no fuel, oil or water is leaking or has leaked into the bilge compartment.
- Check all hoses and connections for leakage and damage.
- Check that all batteries are fully charged.
- Check electrical circuits (lights, pumps, horn, etc.) for proper operation.
- Check that steering system operates properly.
- Be sure the boat is not overloaded.
- Check that all maintenance has been performed.



WARNING

DO NOT OPERATE THE BOAT IF ANY PROBLEM IS FOUND DURING THIS INSPECTION. A PROBLEM COULD LEAD TO AN ACCIDENT DURING THE OUTING CAUSING SEVERE INJURY OR DEATH. PROBLEMS FOUND DURING THIS INSPECTION SHOULD BE HANDLED BY YOUR COBALT DEALER.

ENVIRONMENTAL CONSIDERATIONS

As a boater, you already appreciate nature’s beauty and the peace of the great outdoors. It is a boater’s responsibility to protect the natural environment by keeping waterways clean.

MARPOL TREATY

The USCG enforces the International Convention for the Prevention of Pollution from ships, commonly referred to as the MARPOL Treaty (MARine POLLution). This treaty prohibits the overboard dumping of all ship-generated plastics, chemicals, garbage and oil.

FUEL/SPILLAGE

The spilling of fuel or oil into our waterways contaminates the environment and is dangerous to wildlife. Do not discharge or dispose of fuel or oil into the water; it is prohibited and you can be fined. These are two common, accidental types of discharge:

- Overfilling the fuel tanks
- Pumping contaminated bilge water

CALIFORNIA AIR RESOURCE BOARD (CARB) LABEL

Your boat may have an environmental star label affixed on the bow, port side of the boat as part of the California Air Resource Board (CARB) SD/I rule. This label must stay affixed to the boat if it is operated in California. The label identifies your boat is equipped with a California Certified Engine. The label is positioned so it will be at the leading or trailing edge of the state registration numbers.



WARNING

FUMES FROM RAGS CAN COLLECT IN BILGE AND BE EXTREMELY HAZARDOUS. DO NOT STORE RAGS USED TO WIPE-UP FUEL, SOLVENT SPILLS IN THE BOAT OR RAGS USED FOR TREATING TEAK. DISPOSE OF RAGS PROPERLY ASHORE.

DISCHARGE/DISPOSAL OF WASTE

Waste means all forms of garbage, plastics, recyclables, food, wood, detergents, sewage, and even fish parts in certain waters – in short, nearly everything. We recommend you bring back everything you take out with you for proper disposal ashore.

Use an approved pump-out facility at your marina. Many areas prohibit the discharge of sewerage overboard or even an operable overboard waste discharge.

**EXCESSIVE NOISE**

Noise means engine noise, radio noise or even voices. Many bodies of water have adopted noise limits. Don't use thru-transom exhaust unless you're well off shore. Music and loud conversation can carry a considerable distance on water, especially at night.

WAKE/WASH

Be alert for NO WAKE zones. You may be responsible for any damage or injury caused by your wake/wash. Prior to entering a no wake zone, come off plane to the slowest steerable speed.

EXHAUST EMISSIONS

Increased exhaust (hydrocarbon) emissions pollute our water and air. Keep your engine tuned and boat hull clean for peak performance. Consult your Cobalt dealer and propulsion unit operator's manual for information.

PAINTS

If your boat is kept in water where marine growth is a problem, the use of anti-fouling paint may reduce the growth rate. Be aware of environmental regulations that may govern your paint choice. Contact your local boating authorities for information.

CLEANING AGENTS

Household cleaners should be used sparingly and not discharged into waterways. Do not mix cleaners and be sure to use plenty of ventilation in enclosed areas. DO NOT use products which contain phosphates, chlorine, solvents, non-biodegradable or petroleum based products. Citrus-based cleaners are excellent for marine cleaning purposes and are safe for you and the environment.

FISHERY RESOURCES

There is a tremendous drain on our fishery resources. Over-fishing and pollution have strained the fish population. Do your part by keeping only what you will eat and practice catch-and-release.

FOREIGN SPECIES

If you trailer your boat from lake to lake, you may unknowingly introduce a foreign aquatic species from one lake to the next. Thoroughly clean the boat below the water line, remove all weeds and algae, and drain the bilge before launching the boat in a new body of water.

EMERGENCY CONSIDERATIONS

Be prepared to deal with emergencies before they happen. Try to formulate plan for each type in advance so that decisions can be made quickly and without hesitation. Precious moments lost can mean the difference between losing and saving a life.

FIRE

You must be prepared and act quickly when dealing with a fire. It is not recommended to battle a fire for an extended period of time. Turn engine(s) OFF and abandon the boat if the fire cannot be extinguished quickly. Swim at least 23 meters (25 yards) upwind from the boat and use the visual distress signals to get assistance.



WARNING

GASOLINE WILL FLOAT ON TOP OF WATER AND CAN BURN. IF THE BOAT IS ABANDONED, SWIM UP WIND, FAR ENOUGH TO AVOID FUEL THAT MAY SPREAD OVER THE SURFACE OF THE WATER TO AVOID SERIOUS INJURY.

Onboard fires involving the fuel system usually result in either an explosion that completely destroys the boat, or the boat burning to the waterline and self-extinguishing. Deciding on abandoning the boat or staying to fight the fire is difficult and depends on many factors. Try to formulate a fire plan in advance to make that decision quickly and without hesitation.

Be sure to:

- Use caution and do not smoke when refueling.
- Verify that fuel does not leak.
- Use only marine approved equipment on your boat.

FLOODING/SWAMPING

Improper loading, handling, water conditions, weather and anchoring are the most common causes of flooding. Insist on a safe, stable load. Do not operate the boat exceeding your ability to maneuver it. Use extreme caution in hazardous weather and rough water conditions. Anchor from the bow when using one anchor.

COLLISIONS/LEAKS

If a collision occurs, immediately account for all passengers. Assess the hull for damage and activate the bilge pumps to reduce any water intake. Try to operate the boat to keep the damaged area above water. If necessary, call or signal for assistance.

If a leak is discovered, immediately determine the cause. A collision with an underwater object could cause the hull to develop a leak. A loose fitting or hose clamp on a piece of equipment could cause a leak. Try to repair the leak if possible. If a leak is threatening the safety of you and your passengers, call or signal for assistance.

GROUNDING

In the event you run aground, assess the situation before proceeding. Immediately stop any water from entering the boat. Inspect the propulsion units, steering and control systems, and the hull for damage. Maneuver the boat to safe water only if the hull and all operating systems are in satisfactory operating condition. Otherwise, call or signal for assistance.

STORMS

Take common sense precautions if you are forced to operate your boat in stormy conditions.

- Wear personal flotation devices (PFDs).
- Stow gear below deck and batten down equipment on deck.
- Reduce speed and head for a safe place that you can easily reach.
- If you lose power, keep the boat headed into the waves by using the anchor.



WATER RESCUE (MAN OVERBOARD)

Immediately react to a person that has fallen overboard. Keep the victim constantly in your sight. Safely return to the victim as soon as possible. Throw the person a life preserver. Turn the engine(s) off and help the person into the boat.

MEDICAL EMERGENCY

Be prepared in the event of an emergency. Know how to use your first aid kit. Be aware of any special medical conditions of your passengers.

DROWNING

React to a drowning victim the same as described in Water Rescue. Handle the victim with care. They could be injured. If necessary, resuscitate the victim. Immediately signal for help and keep the victim warm.

OPERATION FAILURE

If you experience a propulsion, steering or control failure, immediately turn off the engines. Release the anchor to prevent drifting. Try to determine the failure and repair, if possible. Otherwise, call or signal for assistance.

RADIO COMMUNICATION

Radio communication is the most important avenue of receiving weather reports and Coast Guard warnings, and sending information such as transmitting request for assistance. Use a VHF/FM radio for short-range communication, and a single-sideband radio (SSB) for long-range.

For all U. S. waters, the National Weather Service operates the NOAA Weather Radio (NWR). This service provides continuous weather information on the following VHF/FM frequencies:

Broadcaster	Frequencies
NOAA Weather Radio	162.400 MHz
	162.425 MHz
	162.450 MHz
	162.475 MHz
	162.500 MHz
	162.525 MHz
	162.550 MHz
Coast Guard Marine Information Stations	2670.0 kHz
	4428.7 kHz
	6506.4 kHz
	8765.4 kHz
	13113.2 kHz

It is good practice to periodically monitor the weather. For additional information, refer to your radio operator’s manual in your Owner Information Manual.

A distress call is transmitted on VHF/FM radio channel 16 (156.800 MHz) or 2182 kHz (SSB).



AUDIBLE/VISUAL DISTRESS SIGNALS

Know your audible signals:

- For emergency, the call sign is “Mayday.”
- An urgent situation, the call sign is “Pan-Pan.”
- For navigational safety and weather warnings, the call sign is “Security.”

Repeat the call sign three times.

Immediately react to a distress call. Assist, if possible, using an emergency frequency. Otherwise continue to monitor the situation until help has arrived.

If you are required to carry distress signals, you must have three USCG approved pyrotechnic devices. Be sure they are in serviceable condition, not exceeding the expiration date and stored in a cool, dry location in a waterproof container.



WARNING





PYROTECHNIC SIGNALING DEVICES CAN CAUSE INJURY AND PROPERTY DAMAGE IF IMPROPERLY HANDLED. FOLLOW THE MANUFACTURER’S DIRECTIONS.

CELLULAR TELEPHONE

A cellular phone can be extremely convenient. Cellular telephone service continues to improve by expanding service areas and advancing technology.

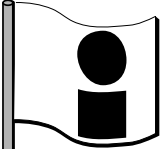
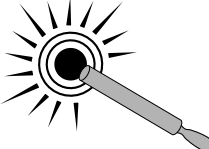
Seek the latest available information regarding network providers in your boating area before purchasing cellular telephone service.

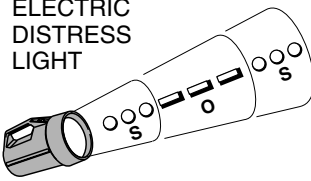
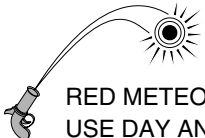
VISUAL DISTRESS SIGNALS

 <p>ORANGE FLAG</p> <p>USE DAY ONLY</p>	<p>RED DISTRESS FLARE (HAND)</p>  <p>USE DAY AND NIGHT</p>
 <p>ARMS SIGNALS (USE BRIGHT CLOTH)</p> <p>USE DAY ONLY</p>	<p>USE DAY ONLY</p>  <p>ORANGE SMOKE SIGNAL (HAND)</p>
<p>ELECTRIC DISTRESS LIGHT</p>  <p>USE NIGHT ONLY</p>	 <p>RED METEOR FLARE</p> <p>USE DAY AND NIGHT</p>
<p>DYE MARKER</p>  <p>USE DAY ONLY</p>	

KC-0082



GENERAL SAFETY

II

The popularity of boating and other water sports has undergone an explosion in growth the past few years. Because of this, safety is an important issue for everyone who shares in the use of our waterways.

WARNING

- ***READ AND UNDERSTAND THIS MANUAL AND THE PROPULSION UNIT MANUAL, AND BE SURE THAT YOU UNDERSTAND ALL CONTROLS AND OPERATING INSTRUCTIONS BEFORE ATTEMPTING TO OPERATE THE BOAT. IMPROPER OPERATION CAN BE EXTREMELY HAZARDOUS.***
- ***BE IN CONTROL OF YOUR BOAT. DO NOT OPERATE YOUR BOAT UNDER THE INFLUENCE OF ALCOHOL OR OTHER DRUGS.***

Before each outing you should check all safety equipment, such as fire extinguishers, PFDs, flares, distress flags, flashlights, engine stop switch, etc. They should be operable, in good condition, readily visible, and easily accessed.

Check local weather reports before casting off; do not leave the dock area when strong winds and electrical storms are in the area or predicted to be in the area.

Tell someone your travel plans and leave them a float plan. A float plan makes the job of search and rescue much easier for authorities. A float plan template can be found in the back of this manual.

SEATING

Keep your passengers seated in seats. The boat's bow, gunwale, transom platform and seat backs are not intended for use as seats while underway.

WARNING

DO NOT ALLOW PASSENGERS TO SIT IN THE TWO STERN SUN LOUNGES WHEN THE BOAT IS UNDERWAY.

HANDHOLDS

Handholds are provided for your passengers' safety. Be sure your passengers use the handholds whenever the boat is underway. Failure to use handholds could result in a man overboard situation or personal injury.

WARNING

PASSENGERS SHOULD USE HANDHOLDS WHENEVER THE BOAT IS UNDERWAY.



CAPACITY

Know the weight capacity of your boat. Do not overload your boat. Overloading of passengers, personal equipment and supplies could result in an accident, especially in rough waters.

LOADING

Be sure that passengers, personal equipment and supplies are in their proper location before operating the boat. It does not necessarily mean you can carry a passenger for every seat. Keep personal equipment and supplies to an “as needed” basis. Maintain a balanced load (front to back and side to side) at all times.

OPERATING CONDITIONS

Every waterway poses hazards that you should avoid, such as shallow water, tree stumps and sand bars. Ask local boaters for information and consult a marine chart when boating on unfamiliar waters. As the operator of the boat, you should try to avoid all hazards, known and unknown. The following information does not contain all possible water hazards.

Operating in shallow water presents a number of hazards. Mud, sand, weeds and debris can foul a propulsion unit propeller or its cooling water. If a propulsion unit strikes an underwater object, check the propulsion unit and boat for damage. If a propulsion unit vibrates after striking an object, it may indicate a damaged propeller.

Sand bars in narrow inlets are constantly shifting, making it difficult to mark them with buoys. Tides in coastal areas affect water levels producing sand bars. Sometimes sand bars are indicated by waves as they form into breakers when passing over the sand bar. Refer to Grounding, in this section, if you run aground on a sand bar.

The water level around a dam spillway is a hazardous area. It is subject to rapid changes caused by currents and turbulence. Keep clear of the spillway areas below dams.

WEATHER/SEAS

Getting caught in severe weather is hazardous. Check with local weather stations, the USCG, or Weather Service Broadcasts for the latest conditions. It is recommended to check the weather, sea and wind conditions not only before, but, periodically while you are boating.

A change in wave height, wind direction and speed indicates deteriorating weather. Take common sense precautions if you are forced to operate your boat in stormy conditions:

- Wear PFDs.
- Stow gear below deck and batten down equipment on deck.
- Reduce speed and head for a safe place that you can easily reach.
- If you lose power, keep the boat headed into the waves by using the anchor.



WARNING

WEAR YOUR PFD AND REMAIN SEATED WHEN OPERATING THE BOAT.

DAYTIME WARNING	DESCRIPTION	NIGHTTIME WARNING
	Small Craft Advisory - Winds greater than 18 knots, sustained for two hours or more or hazardous wave conditions. Following a storm, hazardous wave conditions can persist long after the high winds have subsided.	
	Gale Warning - Sustained winds (2 or more hours), of 34-47 knots.	
	Storm Warning - Sustained winds of 48 knots or greater.	
	Hurricane Warning - Forecast winds of 64 knots and above. Displayed only in connection with a hurricane.	

KC-0371.2

Learn the storm signals.

It is best to avoid operating your boat in foggy weather. When fog sets in, use your GPS and radar unit, if equipped, to take bearings and log courses and speeds. You are required to emit a five-second blast from your horn or whistle once every minute. Additionally, have passengers wear PFDs and observe for oncoming vessels.

SKILL/EXPERIENCE

Practice your boat operating skills often in calm water. Avoid windy conditions and rough water. Be sure to maintain good visibility at all times. Do not practice close to any obstructions such as piers, bridges, swim areas or moored boats.

Proceed slowly and give yourself plenty of time to react. Remember, your boat is not an automobile. It requires additional time to maneuver and stop.



VISIBILITY

Visibility is not only sight, but also hearing. It is very important the operator maintains good visibility at all times. Arrange passengers and equipment to ensure you have unobstructed vision at all times. Check for other boats or any obstacles before turning the boat.



WARNING

CLEAR VISIBILITY MUST BE MAINTAINED AT ALL TIMES. IF NECESSARY, ARRANGE PASSENGERS AND EQUIPMENT. DESIGNATE A PASSENGER TO ASSIST WHEN VISIBILITY IS LIMITED DUE TO OPERATING CONDITIONS.



KC-0153.2

DRUGS/ALCOHOL

Boating, alcohol and the use of other drugs just don't mix. Mixing boating, alcohol and other drugs result in many marine accidents and deaths. These substances reduce your reaction time and affect your better judgement. Combined with the sun, wind, waves, and noise of other watercraft, the effects of drugs are increased and will significantly reduce your reaction time. As the owner/operator, you are responsible for the alcohol/drug use and onboard behavior of your passengers.



WARNING

FEDERAL AND STATE LAW PROHIBIT OPERATING A BOAT UNDER THE INFLUENCE OF ALCOHOL AND OTHER DRUGS. THESE REGULATIONS ARE ACTIVELY ENFORCED. IMPAIRED OPERATION MAY RESULT IN SEVERE PERSONAL INJURY OR DEATH.



NOTE

If the operator's blood alcohol content is 0.10% (0.08% in some states) or above, violators are subject to a civil penalty up to \$1,000.00 or criminal penalty up to \$5,000.00, one year imprisonment or both. Operating a boat under the influence can also result in a loss of automobile driving privileges.

PASSENGERS

Whenever you are going for an outing, make sure that at least one passenger is familiar with the operation and safety aspects of the boat in case of emergency. Show all passengers the location of emergency equipment and explain how to use it. Don't allow passengers to drag their feet or hands in the water, or sit on the bow, deck, gunwale or transom platform while the engines are running.



VENTILATION

Carbon Monoxide (CO) is a colorless and odorless gas produced by all engines and fuel burning appliances such as heaters, stoves and generators. Even with the best boat design and construction, plus the utmost care in inspection, operation, and maintenance, hazardous levels of CO may still be present in accommodation spaces under certain conditions. Dizziness, ears ringing, headaches, nausea, unconsciousness and cherry red skin color are symptoms of carbon monoxide poison.

To reduce CO accumulation:

- Ventilate the boat interior by opening the deck hatches, windows and cabin door to provide adequate ventilation.
- Do not operate the engines or generator with the canvas installed.
- Only operate fuel burning appliances in well-ventilated areas.
- Avoid idling or using the generator while at idle for extended periods.
- Regularly inspect the engine and generator exhaust system for proper operation.
- Do not use any fuel burning appliances with a transom exhaust port when swimming from the stern swim platform.

Have a suspected CO victim deeply breathe fresh air and immediately seek medical attention.



DANGER

CARBON MONOXIDE GAS (CO) IS COLORLESS, ODORLESS AND EXTREMELY DANGEROUS. ALL ENGINES AND FUEL BURNING APPLIANCES PRODUCE CO AS EXHAUST. DIRECT AND PROLONGED EXPOSURE TO CO WILL CAUSE BRAIN DAMAGE OR DEATH. SIGNS OF EXPOSURE TO CO INCLUDE NAUSEA, DIZZINESS AND DROWSINESS.



WARNING

TEST THE CARBON MONOXIDE DETECTORS OPERATION BEFORE EACH TRIP, AT LEAST ONCE A WEEK AND AFTER THE BOAT HAS BEEN IN STORAGE. DO NOT TAMPER WITH THE OPERATION OF THE CARBON MONOXIDE DETECTORS. THEY ARE INSTALLED FOR YOUR SAFETY.



CAUTION

A CARBON MONOXIDE (CO) DETECTOR WILL ONLY DETECT THE PRESENCE OF CARBON MONOXIDE GAS AT ITS SENSOR. CARBON MONOXIDE MAY BE PRESENT IN OTHER AREAS.



NOTE

A carbon monoxide detector will not detect other vapors such as gasoline.



DANGER

EXTREME HAZARD – CARBON MONOXIDE GAS (CO) IS COLORLESS, ODORLESS AND EXTREMELY DANGEROUS. ALL ENGINES AND FUEL BURNING APPLIANCES PRODUCE CO AS EXHAUST. DIRECT AND PROLONGED EXPOSURE TO CO WILL CAUSE BRAIN DAMAGE OR DEATH. SIGNS OF EXPOSURE TO CO INCLUDE NAUSEA, DIZZINESS AND DROWSINESS. SOURCES OF CO INCLUDE:

1 Blockage of boat exhausts by obstruction.

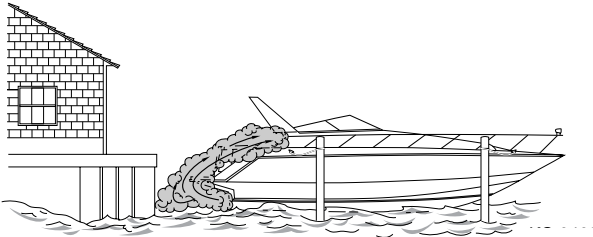

4 Operating with high bow angle.

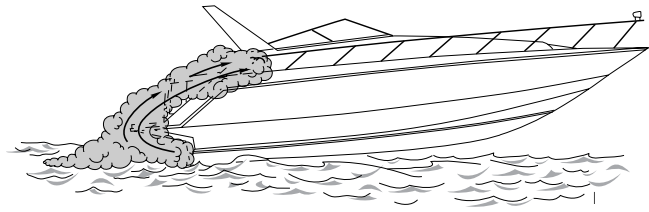

2 Exhausts traveling along obstruction.

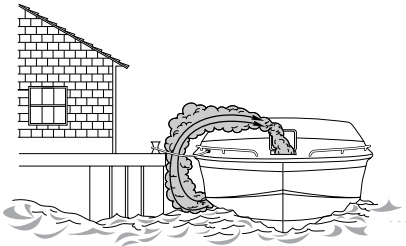

5 Exhausts from other vessels in confined areas.

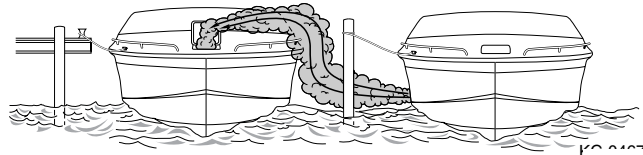

3 Operating at slow speed or while dead in the water.

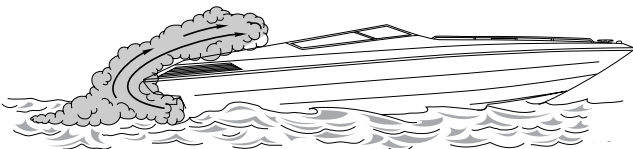

6 Operating with canvas tops and side curtains in place without ventilation.

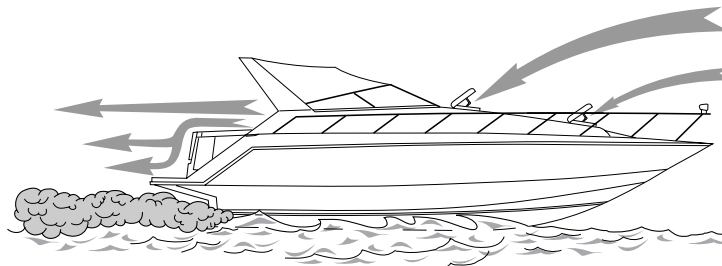
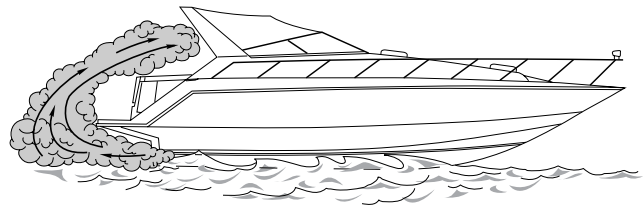

ENSURE ADEQUATE VENTILATION FOR CORRECT AIR MOVEMENT THROUGH BOAT!



QUALIFIED BOAT OPERATORS

This manual is not intended to provide complete training on all aspects of boat operation. We strongly recommend that all operators of this boat seek additional training on boat handling and safety. Have all operators become familiar with the handling characteristics, and proper steering and control system usage before attempting high-speed operation.

Some states require youths 16 years of age and younger to complete a boating safety course before operating any watercraft. Many others require operators under the age of 18 to be licensed in small boat operation.

Minors must be supervised by an adult whenever operating a boat. Many states have laws regarding the minimum age and licensing requirements of minors. Be sure to contact the state boating authorities for information.

BOATERS EDUCATION REQUIREMENT

Certain states now require mandatory boater education for certain age groups of boaters who operate boats above a certain horsepower and people who are supervising boaters under a certain age. Boaters must carry a Boater Education Card when they are operating a boat and children under a certain age are forbidden to operate a powerboat. Know your state's laws and its requirements.

SAFETY WHILE BOATING

FEDERAL, STATE AND LOCAL REGULATIONS

The USCG is the authority of the waterways; they are there to help the boating public. State boating regulations are enforced by local authorities. You are subject to marine traffic laws and "Rules of the Road" for both federal and state waterways; you must stop if signaled to do so by enforcement officers, and permit to be boarded as asked.

RESTRICTED AREAS

Before boating, check with Local, State and Federal authorities to identify restricted areas. Because of the threat of terrorism, the U.S. Coast Guard has and will continue to implement strict limits on watercraft near U.S. Navy and Coast Guard ships and other potential targets.

DISCHARGE OF OIL

The discharge of fuel, oil and other chemicals into the water is prohibited. Be sure to clean up all fuel and oil spillage in the bilge using rags and sponges. Properly store and dispose of them when you get to shore. Do not allow any fuel or oil spillage to be pumped out into the water. If fuel or oil leakage continues to be a problem, immediately have the problem repaired.

When refueling, do not "top-off" the fuel tanks. Allow for expansion which will reduce fuel spillage from the fuel tank vents.

SOLID WASTE DISPOSAL

The disposal of solid waste and plastics into the water is prohibited. Bag all refuse and properly dispose of it when you get ashore.

Have your Cobalt dealer properly service the waste disposal system when needed.



NOTE

It is illegal to dispose of any plastic trash into waters of the U.S.

MARINE SANITATION

Direct disposal of sanitation waste into some waters could result in being fined. Be sure to check local regulations.



CAUTION

TO AVOID DAMAGING THE WASTE DISPOSAL SYSTEM AND THE ENVIRONMENT, DO NOT PLACE FACIAL TISSUES, PAPER TOWELS OR SANITARY NAPKINS IN THE HEAD.

EXCESSIVE NOISE

Noise limits are regulated in many areas. Be sure to follow regulations and be courteous.

WAKE/WASH

Observe “No Wake” markers. Use caution when operating around smaller crafts, in channels and marinas, and in congested areas.



WARNING

YOU ARE RESPONSIBLE FOR INJURY AND DAMAGE CAUSED BY YOUR WAKE.

REPORTING ACCIDENTS

The USCG requires the owner or operator of a boat involved in an accident, to report the incident to the proper marine law enforcement agency for the state in which the accident occurred. Immediate notification to the nearest State boating authority is required if a person dies or disappears as a result of a recreational boating accident. If a person dies or sustains injuries requiring more than first aid, a formal report must be filed within 48 hours of the accident. A formal report must be filed within 19 days for accidents exceeding \$500 in property damage or complete loss of boat.

RENDERING ASSISTANCE

If you see a distress signal or suspect a boat is in trouble, you must assume it is a real emergency and render assistance immediately. By law, the operator in charge of the craft is obligated to provide assistance to any individual in danger if such assistance can be provided safely. Failure to render assistance can result in a fine and/or imprisonment.

The 1971 Boating Safety Act grants protection to a “Good Samaritan” boater providing good faith assistance, and absolves a boater from any civil liability arising from such assistance.



WATERSPORTS SAFETY

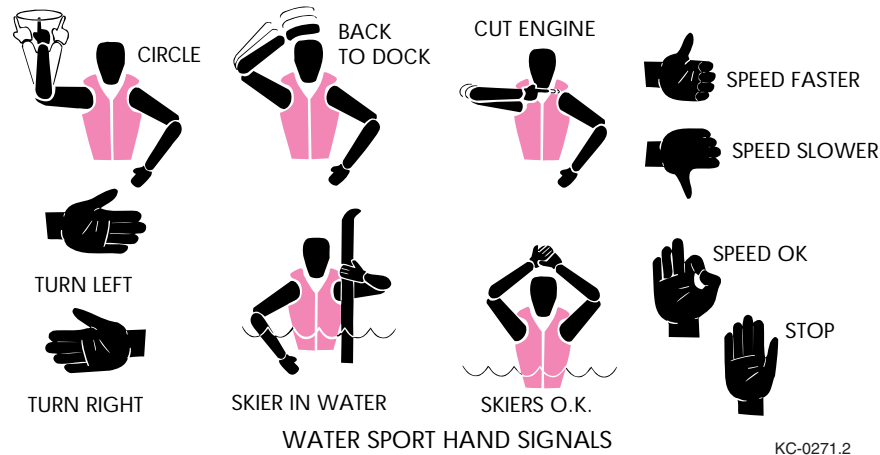

When participating in water sports, be safe and courteous and follow these guidelines:

- Be considerate to fishermen and others you share the water with.
- Do not perform water sports in congested areas.
- Stay away from navigation markers.
- Stay away from other boats and water sports participants.
- Return immediately to a fallen water sport participant.
- Regularly inspect water sport equipment to ensure it is safe.
- Do not use any fuel burning appliances with a transom exhaust port when swimming from the stern swim platform.



NOTE

It is unlawful to participate in water sports while under the influence of alcohol or other drugs.



WARNING

- **WATER SPORT PARTICIPANTS MUST WEAR A USCG APPROVED FLOTATION DEVICE. A TYPE III WATER SKI VEST IS AN APPROVED AND PRACTICAL PFD.**
- **KEEP AT LEAST 30 M (100 FT) AWAY FROM ALL OTHER OBJECTS.**
- **WHEN WATER SPORTING, HAVE AN EXPERIENCED DRIVER AND AFT FACING OBSERVER IN THE BOAT.**
- **DO NOT WATER SPORT IN SHALLOW WATER OR AT NIGHT.**
- **DO NOT JUMP FROM A MOVING BOAT.**
- **KEEP A DOWNED WATER SPORTER IN SIGHT.**
- **TURN THE ENGINES OFF BEFORE YOU GET CLOSE TO SOMEONE IN THE WATER.**





III NAVIGATION

“RULES OF THE ROAD”/SOUND SIGNALS

The General Prudential Rule regarding right-of-way is that if a collision appears unavoidable, neither boat has right-of-way. As prescribed in the “Rules of the Road,” both boats must act to avoid collision.

The information in this section outlines only the most basic of the nautical “Rules of the Road.” For more information, contact your local USCG Auxiliary.



WARNING

THE NAUTICAL "RULES OF THE ROAD" MUST BE FOLLOWED TO PREVENT COLLISIONS BETWEEN VESSELS. LIKE TRAFFIC LAWS FOR AUTOMOBILES, THE OPERATOR IS LEGALLY REQUIRED TO FOLLOW THE RULES.

ENCOUNTERING VESSELS

WHISTLE/HORN SIGNALS

Signaling other boats with a whistle or horn is similar to using turn signals on an automobile. It is not necessary to sound a signal every time a boat is nearby. In general, boat operators should signal their intention to avoid potentially confusing or hazardous situations.

It is customary for the privileged boat to signal first, and the give-way boat to return the same signal to acknowledge she understands and will comply. Use the danger signal (five or more short and rapid blasts) if intent is not clear.

Use the following signal blast early enough to be noticed and understood by other boaters:

- One long blast: Warning signal (coming out of slip or passing astern)
- One short blast: Pass on my port side
- Two short blasts: Pass on my starboard side
- Three short blasts: Engines in reverse
- Five or more short and rapid blasts: Danger signal!



NOTE

In general, boats with less maneuverability have right-of-way over more agile craft. You must stay clear of the vessel with right-of-way and pass to his stern.



PRIVILEGED BOATS

Privileged boats have right-of-way and can hold course and speed. Sailboats and boats paddled or rowed have the right-of-way over motor boats. Sailboats under power are considered motorboats. Small pleasure craft must yield to large commercial boats in narrow channels.

BURDENED BOATS

The burdened boat is the boat that must make whatever adjustment to course and speed necessary to keep out of the way of the privileged boat.

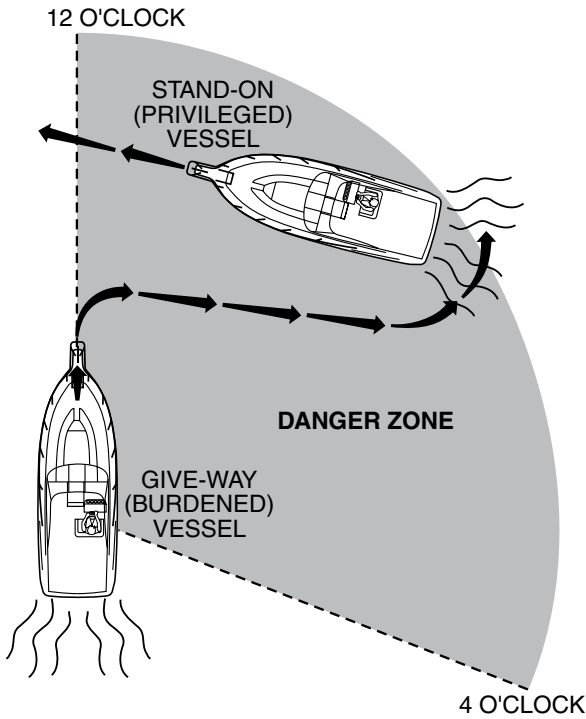

KC-0477

CROSSING SITUATION

In crossing situations, the boat to the right from the 12 o'clock to the 4 o'clock position has the right-of-way. It must hold course and speed. The burdened boat keeps clear and passes behind the privileged boat. Boats going up and down a river have the privilege over boats crossing the river.



MEETING HEAD-ON

Neither boat has the right-of-way in this situation. Both boats should decrease speed, should turn to the right, and pass port-to-port. However, if both boats are on the left side of the channel, each vessel should sound two short blasts and pass starboard-to-starboard.

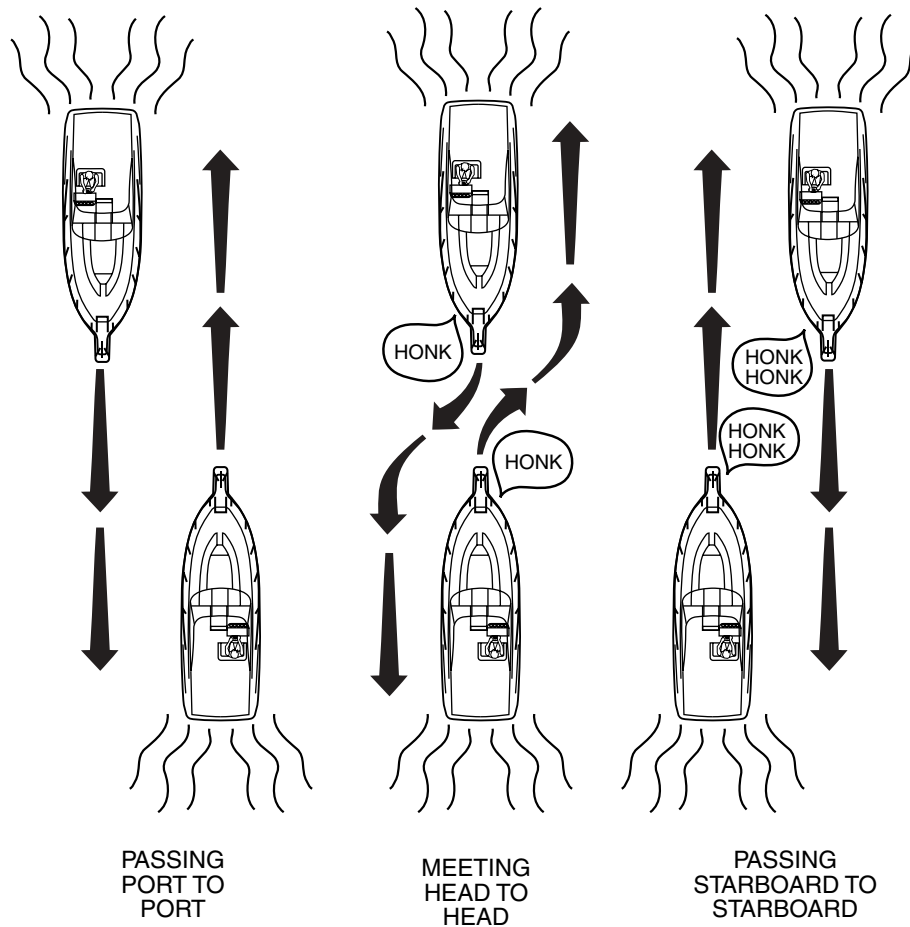

KC-0475



OVERTAKING

The boat that is overtaking one ahead of it is the give-way boat and must make any adjustments necessary to keep out of the way of the stand-on boat. The stand-on boat should hold its course and speed.

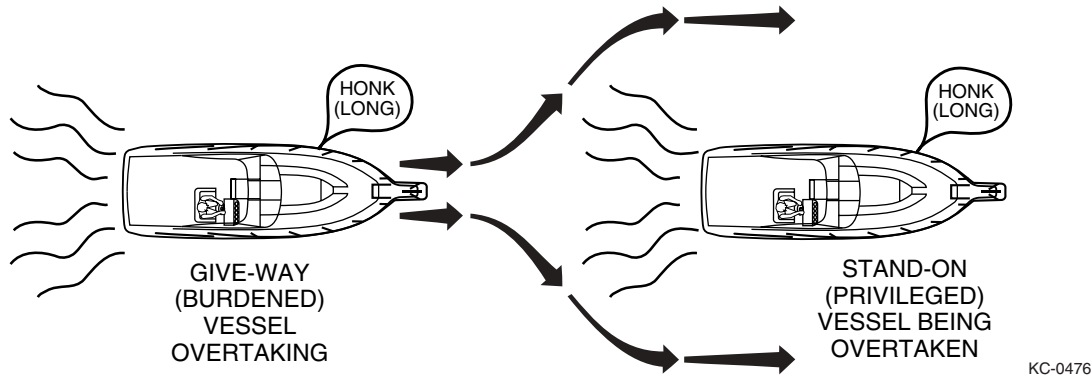

NAVIGATIONAL AIDS

Learn to recognize the different buoys and day markers; they are the signposts of the waterways. There are two primary marking systems in use in the U.S.; the Uniform State Waterway Marking System (USWMS) used on inland waters and maintained by each state, and the Federal Waterway Marking System (FWMS) used on coastal waters and rivers and maintained by the USCG. In addition, the FWMS has two modified systems; the Western River Buoyage, and the Intercoastal Waterway Buoyage. Be sure to check with local authorities on the buoyage system in use.

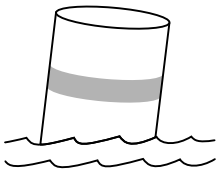

WHITE WITH BLUE BAND

MAY SHOW WHITE REFLECTOR OR LIGHT

KC-0412

The only buoys you are permitted to moor to are mooring buoys. Mooring to a navigation buoy or other navigational aid or regulatory marker is illegal.

The type of hazard/warning buoys and markers depend on the area of jurisdiction. Check with local boating authorities.

The USWMS Cardinal System is used when there is no well defined channel or where an obstruction may be approached from more than one direction. With the cardinal system:

- Pass north or east of BLACK-TOPPED WHITE buoy.
- Pass south or west of RED-TOPPED WHITE buoy.
- RED and WHITE VERTICALLY STRIPED buoy indicates boat should pass outside of the buoy (away from shore).



UNIFORM STATE REGULATORY MARKERS

USWMS regulatory markers are white with international orange geometric shapes; you must obey regulatory markers.

UNIFORM STATE WATERWAY MARKING SYSTEM (USWMS)

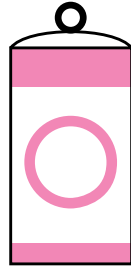

CONTROLLED AREA

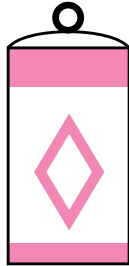

DANGER

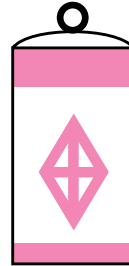

BOATS KEEP OUT

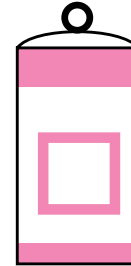

INFORMATION



DO NOT PASS BETWEEN SHORE AND BUOY



SPECIAL PURPOSE

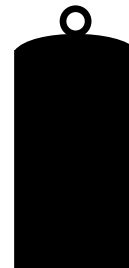

NAVIGATE TO STARBOARD FACING UPSTREAM

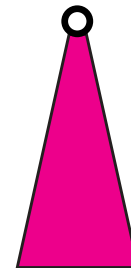

NAVIGATE TO PORT FACING UPSTREAM

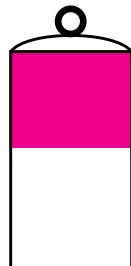

NAVIGATE TO SOUTH OR WEST



NAVIGATE TO NORTH OR EAST



MID-CHANNEL

KC-0411.2



FWMS

The FWMS Lateral System is for use on navigable waters except Western Rivers and Intercoastal Waterways.

The markings on these buoys are oriented from the perspective of being entered from seaward (the boater is going toward the port). This means that red buoys are passed on the starboard (right) side of the vessel when proceeding from open water into port, and green buoys to the port (left) side.

The right side (starboard) of the channel is marked with RED, even numbered buoys. The left (port) side of the channel is marked with GREEN, odd numbered buoys.

The middle of the channel is marked with RED and WHITE vertically striped buoys; pass close to these buoys.









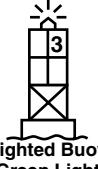
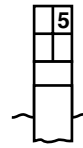

Obstructions, channel junctions, etc. are marked with RED and GREEN horizontally striped buoys.

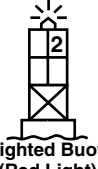
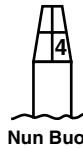
A RED band at the top means the preferred channel is to the left of the buoy; a GREEN top band means the preferred channel is to the right of the buoy.

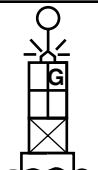
Day markers are colored and numbered the same as buoys. RED, triangular day markers with even numbers mark the starboard side of the channel. GREEN, square day markers with odd numbers mark the port side of the channel.

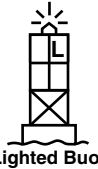
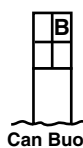
Lights, bells and horns are used on buoys for night or poor visibility conditions. Buoys with unique light flashing characteristics are identified on nautical charts with the specific flashing pattern.

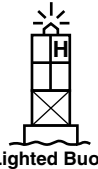
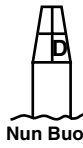

Lateral Aids Marking the Sides of Channels as seen When Entering From Seaward	Port Side Odd Numbers (Green)	 Lighted Buoy (Green Light)	 Can Buoy	 Daymark
	Starboard Side Even Numbers (Red)	 Lighted Buoy (Red Light)	 Nun Buoy	 Daymark
Safe Water Aids Marking Mid-Channels and Fairways (No Numbers—May be Lettered)	(Red)	 Lighted (White Light)	 Spherical Buoy	 Daymark
Preferred Channel Aids (No Numbers—May be Lettered)	Preferred Channel to Starboard (Green and Red)	 Lighted Buoy (Green Light)	 Can Buoy	 Daymark
	Preferred Channel to Port (Green and Red)	 Lighted Buoy (Red Light)	 Nun Buoy	 Daymark

KC-0441

LIGHT STRUCTURES

Maneuvering a boat at night can be dangerous and confusing. To aid boaters with navigation and warn of hazards, the USCG and the state and local authorities maintain a variety of light structures. Some light structures may be equipped with radio beacons, radar reflectors, and/or signals.

MINOR LIGHTS

Minor lights are colored according to the buoyage marking system in use. They are similar to lighted buoys, except they are usually higher and on more stable platforms to increase visibility. Most minor lights are part of a series to mark a channel, river or harbor.



RANGE LIGHTS

Range lights are usually visible in one direction and help a boat operator navigate in a generally safe direction. Steering a course to keep range lights arranged in a line (one on top of the other) will help guide a boat through a channel.

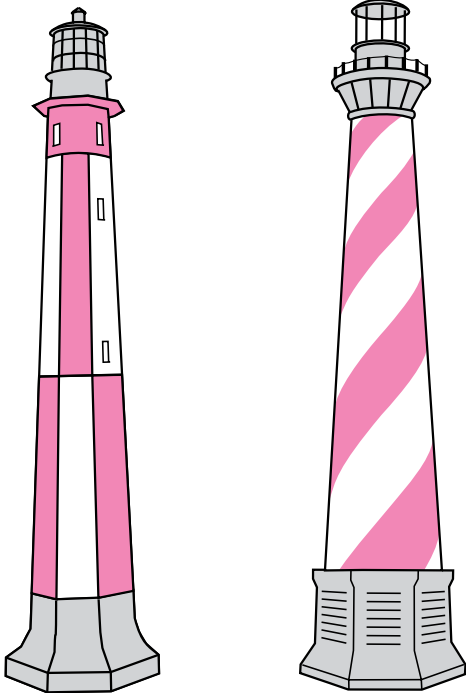
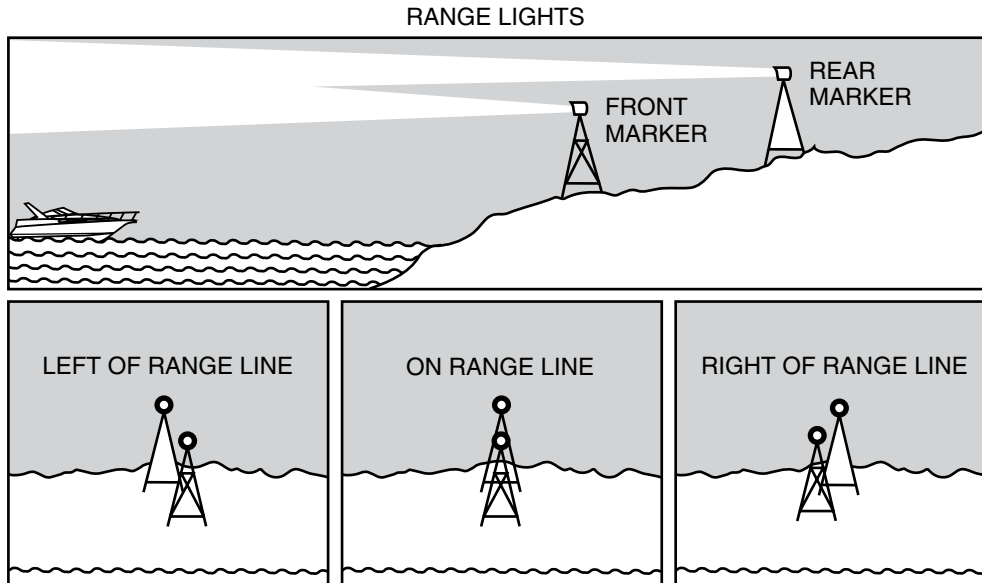

LIGHTHOUSES

Lighthouses can be found at harbor entrances, prominent headlands, isolated danger areas, and along the coast. These striped or patterned structures have unique flashing characteristics to help identify them.

KC-0443.2



WARNING MARKERS

DIVERS FLAG

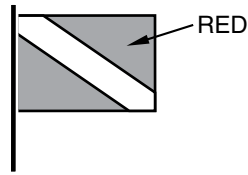

USED BY RECREATIONAL DIVERS - INDICATES DIVER'S POSITION

ALPHA FLAG

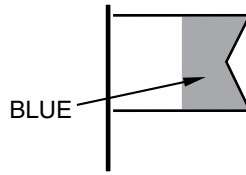

WORLDWIDE VESSELS ENGAGED IN DIVING OPERATIONS - DOES NOT INDICATE DIVER'S POSITION

DISTRESS FLAG

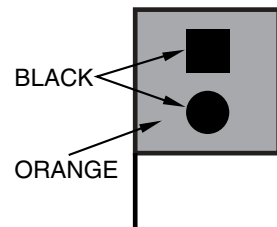

INDICATES FELLOW BOATER IS IN NEED OF ASSISTANCE

KC-0352

It is a good idea to ask local authorities if there are hazardous areas and how they are marked. Boaters must also recognize the flag designs which indicate that skin divers are present and keep well clear of the area.

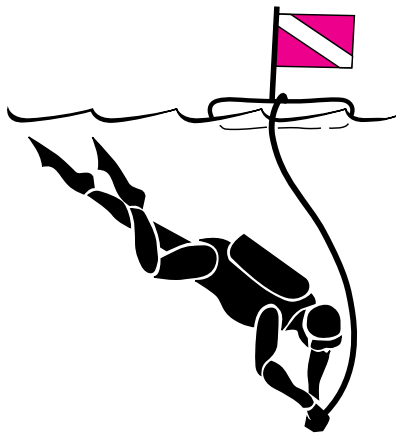

KC-0250.2

Watch for swimmers. Swimming areas may not be marked. Steer clear from the area and remain alert.



KC-0260.2

Navigation markers serve as a means of identifying navigable routes, and indicate water hazards. Boaters should become familiar with navigation markers and stay within marked boundaries and clear of hazards.





OPERATING INFORMATION

This section is not intended to provide complete training on all aspects of boat operation. We strongly recommend that all operators of this Cobalt boat seek additional training on boat handling and safety. Have all operators become familiar with the handling characteristics and proper steering and control system usage before attempting high-speed operation.

PRECAUTIONS

Become familiar with the location and operation of all equipment. Have emergency plans in place. Be sure to perform a safety check before operating your boat.



WARNING

READ AND UNDERSTAND THIS MANUAL AND THE PROPULSION UNIT OPERATOR'S MANUAL, AND BE SURE THAT YOU UNDERSTAND ALL CONTROLS AND OPERATING INSTRUCTIONS BEFORE ATTEMPTING TO OPERATE THE BOAT. IMPROPER OPERATION CAN BE EXTREMELY HAZARDOUS.

Your safety, the safety of your passengers, and other boaters are among your responsibilities as operator of this boat. Your boat must be in compliance with USCG safety equipment regulations. You should know how to react correctly to adverse weather conditions, have good navigation skills, and follow the "Rules of the Road" as defined by the USCG and state, county and local regulations.

We cannot stress enough, the importance of reading your propulsion unit operator's manuals and following the manufacturer's instructions for breaking-in your engines.

Before each outing you should check all safety equipment, such as fire extinguishers, PDFs, flares, distress flags, flashlights and engine stop switch. They should be operable, in good condition, readily visible, and easily accessible.

INSTRUMENTATION

Your Cobalt Boat has been outfitted with instruments manufactured by Faria Marine Instruments. Each instrument was manufactured in an ISO 9001 registered facility, built to stringent standards, and passed comprehensive quality control procedures prior to shipment.

THE INSTRUMENT SYSTEM

Your Cobalt Instrument System consists of individual gauges, wiring harnesses, senders, sensors and transducers. Each of these items has their own tolerances. If these tolerances "stack up" in opposite directions it can lead to what may be perceived as a larger difference in operating readings than actually exists. In twin-engine applications it's not unusual for tachometers and gauges to have slightly different readings between engines.



As long as the readings are within the engine's specified operating band, the engines are operating properly.

TACHOMETERS

Most tachometers have a tolerance of $\pm 2\%$ of full scale (± 120 rpm on a 6000-rpm Tach). In twin-engine applications this could mean that there is a 240 rpm difference between Tach readings when the engines are in synch. Tachometers will zero when the key is turned on, it doesn't matter what the Tach reads with the key off.

TRIM GAUGES

Cobalt trim gauges are calibrated to be the most accurate and useful in the engine down or "trim" range. The gauge may not read full "up" in some cases. This is not unusual nor does it indicate a problem with either the trim sender or the gauge.

FUEL GAUGES

Fuel gauges may at some times seem to "bounce." In most circumstances this is actually caused by the fuel sloshing in the tank and does not necessarily indicate a problem with the gauge or sender.

INSTRUMENT FOGGING

Most marine instruments have small vents in their cases to allow moisture out. It is possible for moist air to be drawn into the vents when the air inside the gauge cools down after the instrument is turned off. The morning sun can draw this moisture up against the lens, causing fogging. Turning on the instrument with the instrument light "on" will speed up moisture removal. Fogging is not abnormal, nor will it harm your instrument, which is built to withstand the harsh marine environment.

RADIO TRANSMISSIONS

Some interference (erratic operation) may be noticed on tachometers or synchronizers during radio transmissions. This will not damage the instrument or affect its accuracy when not transmitting.

FUELING

Take care not to spill gasoline. If gasoline is accidentally spilled, wipe up all traces of it with dry rags and immediately dispose of the rags properly ashore. Spilled fuel may yellow the gelcoat finish and damage gunwale trim.



DANGER

GASOLINE IS EXTREMELY FLAMMABLE AND HIGHLY EXPLOSIVE UNDER CERTAIN CONDITIONS. STOP THE ENGINES AND GENERATOR, AND DO NOT SMOKE OR ALLOW OPEN FLAMES OR SPARKS WITHIN 15 M (50 FT) OF THE FUELING AREA.



WARNING

ALL PRECAUTIONS MUST BE TAKEN EVERY TIME YOU FUEL YOUR BOAT, WHETHER IT'S GASOLINE OR DIESEL FUEL. DIESEL FUEL IS NON-EXPLOSIVE, BUT IT WILL BURN.

**CAUTION**

TO PREVENT UNWARRANTED ENGINE DAMAGE, REFER TO YOUR PROPULSION UNIT OPERATOR'S MANUALS FOR RECOMMENDED FUEL TYPE AND OCTANE RATING.

WHEN FUELING:

1. Know your fuel tank capacity. Be sure to have enough fuel to reach your destination. If departing for an extended cruise, know the availability of fuel along your route. Practice the One Third Rule; 1/3 to reach the destination, 1/3 to return and 1/3 in reserve.
2. Avoid fueling at night, except under well-lighted conditions.
3. Moor your boat securely to the dock. Know the location of the fire extinguisher in case of emergency.
4. Keep accurate records of your fuel consumption. A fuel log tracking fuel use over time will help determine average consumption.
5. Close all doors, hatches, windows and other compartments.
6. Extinguish cigarettes, pipes, and all other flame producing items.

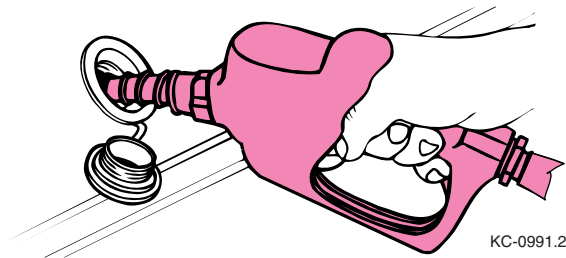

7. Make sure all power is off, and do not operate any electrical switches.
8. Remove the fuel fill cap using the fuel cap key supplied with your boat.
9. Insert the hose nozzle and make sure nozzle is in contact with or grounded against fill opening. This will reduce the risk of static spark.

10. Add fuel in accordance with the propulsion unit operator's manual. Do not overfill, and allow enough room for fuel expansion.

**NOTE**

- *Each time you refuel, inspect all fuel lines, hoses and connections for leaks and deterioration.*
- *The Federal Water Pollution Control Act prohibits the discharge of oil or oily waste into the water. Violators can be fined \$5,000.00. We urge you to protect our fragile environment by avoiding any type of discharge, trash or litter into our waterways.*

AFTER FUELING:

1. Tighten the fuel fill cap using the fuel cap key. Wipe up any fuel spillage.
2. Open all windows, hatches, doors and compartments.
3. Check all fuel lines, hoses and connections for leaks and deterioration.
4. Be sure to run the blower for at least four minutes before starting the engines. If you smell gasoline fumes, do not start the engines; continue to run the blower until fumes have dissipated.



BOARDING

When boarding the boat, always step in. Do not jump. Avoid stepping on fiberglass or other potentially slippery surfaces. Board one person at a time.

Do not board the boat while carrying gear. Set the gear on the dock, board the boat and then pick up the gear.

LOADING

Do not overload your boat. The performance of your boat is dependent on load weight and distribution. Passengers should distribute themselves to maintain trim. Remember to distribute weight from right to left, and also from front to back.

- Avoid excess weight in the bow or stern.
- Securely stow all extra gear in stowage areas to prevent load shifting. Do not stow gear on top of safety equipment; safety equipment must be quickly accessible.
- In adverse weather, reduce the load in the boat. People/load capacity ratings are based upon normal boating conditions.
- Do not use the drive units as a boarding ramp, use the boarding ladder. To prevent injury, make sure the engines are OFF when swimmers, drivers and skiers are boarding.

Overloading of passengers, personal equipment and supplies could result in an accident, especially in rough waters. Maintain a balanced load at all times. Keep the weight distributed evenly. Store all gear in secure areas. Safety equipment must be immediately accessible at all times.



WARNING

ALL PASSENGERS SHOULD BE CAREFULLY SEATED WHILE THE BOAT IS MOVING. DO NOT SIT ON THE BOW, DECK, GUNWALE OR STERN SUNDECK PADS WHEN THE BOAT IS MOVING.

LAUNCHING

Federal and local laws require certain safety equipment to be on board at all times. In addition, responsible boaters carry other equipment in case of an emergency. Check with local boating authorities for any additional requirements over and above federal requirements.

For maximum enjoyment and safety, check each of these items BEFORE you start your engines:

- Install drain plug.
- Have enough life-saving devices for every person onboard.
- Be sure the steering system operates smoothly and properly.
- Verify the amount of fuel in the fuel tanks.
- Verify the batteries are fully charged.



- Check weather conditions.
- Be sure the lights, horn, bilge pumps and other electrical equipment are in operating conditions.
- Be sure the fire extinguisher, signaling devices and other emergency gear are onboard and in proper operating condition.

ON THE WATER

Start your engines before casting off. Remember, the boat turns from the stern, therefore, allow plenty of space between the boat and the dock before trying to move away.

GETTING UNDERWAY

There are many things to consider to make your boating trip safe and enjoyable. You are responsible for the safety of all passengers, the boat and any damage the boat or its wake may cause. Keep passengers from blocking your view so that you do not run into other boats, swimmers, water skiers, personal water vehicles or aids to navigation.

IGNITION SAFETY SWITCH

Your Cobalt is equipped with an ignition safety switch. It is located on the face of the side mount control or near the lower edge of the driver's control panel.

The ignition safety switch stops the engine(s) when engaged. Attach the lanyard to the driver whenever the engines are running. If the driver leaves the driver's station, the lanyard will shut off the ignition immediately preventing the boat from moving under power.

Attach the lanyard to the safety switch. Hook the opposite end on the lanyard to a strong piece of clothing on the driver, such as a belt loop.

If the lanyard is lost, the switch may be overridden for temporary engine operation but only in emergencies. Contact your Cobalt dealer immediately if a replacement lanyard is needed.

SINGLE BATTERY SWITCH

Your Cobalt is equipped with a master battery switch. With this switch turned off, nothing in the boat will operate except for the automatic bilge pump. If you have the optional dual battery system, make sure the master switch is in the "1" or "2" position. You can operate the boat with the switch in the "both" position but not for extended periods.

DUAL BATTERY AND SWITCH – STANDARD ON 293

This option gives you the ability to isolate the entire boat from the batteries, and switch to either or both batteries. Under normal situations, the switch should be in "position 1" or "position 2" rather than the "all" position. This will keep one battery in reserve should the other fail. Battery selection should be made with engine off only. We recommend alternating batteries on a daily basis. In the off position, the entire boat is isolated electrically with the exception of the automatic bilge pump circuit.



NOTE

The purpose of dual batteries is to keep one as a spare. In the "both" position, you essentially have one larger battery and if a failure should occur with the electrical systems or either battery, both batteries will end up discharged.



STARTING ENGINES

Please refer to the propulsion unit operator's manual for starting procedure information.



WARNING

OPERATE THE BLOWER FOR AT LEAST FOUR MINUTES EACH TIME YOU START THE ENGINES. IN ADDITION, THE BLOWER SHOULD BE OPERATED CONTINUOUSLY WHEN AT IDLE AND DURING SLOW SPEED OPERATION. FAILURE TO OPERATE THE BLOWER CAN CAUSE AN EXPLOSION.



WARNING

START THE ENGINES WITH THE SHIFT CONTROL LEVERS IN NEUTRAL. YOUR BOAT IS EQUIPPED WITH A NEUTRAL SAFETY SWITCH WHICH WILL NOT ALLOW ENGINES TO BE STARTED UNLESS THE SHIFT CONTROL LEVERS ARE IN THE NEUTRAL POSITION.

SHIFTING

Follow these guidelines when shifting your boat:

- Pause in NEUTRAL before shifting from FORWARD to REVERSE, or REVERSE to FORWARD.
- Avoid shifting into REVERSE while the boat is traveling forward at speed.
- Keep the control area clean and clear of obstructions.



CAUTION

GO SLOWLY IN REVERSE TO AVOID TAKING WATER IN OVER THE TRANSOM. YOU CAN SWAMP THE BOAT BY TAKING ON TOO MUCH WATER.

STEERING

The steering system in your Cobalt is the finest available in the boating industry today. It is a mechanical system, with power assist in all sterndrive installations.

STEERING/PROPELLER TORQUE

Steering or propeller torque is always present in any drive system. In some systems, it is more noticeable than in others. Your boat has power steering and you should not encounter this torque to any significant degree. If you encounter movement in the steering wheel when released, please check with your dealer. It may be necessary to adjust the power steering assembly. These adjustments should only be made by a qualified service person. The steering system in your Cobalt is one of the most important systems and should be checked on a regular basis by an Authorized Cobalt Service Dealer for proper operation.

WANDERING/FISHTAILING

Wandering is a characteristic of all deep vee hulls at slow speed. There is no cure for wandering, however, a very basic operational technique can be applied which will minimize this characteristic. If the steering wheel is moved back and forth to compensate for wandering, invariably, the situation will be accentuated. If the steering wheel is left in a centered position, the boat will wander back and forth slightly, however, the overall course of the boat will be a straight one.



WARNING

- **THE STEERING IS THE MOST IMPORTANT SYSTEM IN THE ENTIRE BOAT FROM A SAFETY STANDPOINT. HAVE THIS SYSTEM INSPECTED AND MAINTAINED ON A QUARTERLY BASIS BY A QUALIFIED SERVICE TECHNICIAN.**
- **THE BOAT'S STEERING SYSTEM IS NOT SELF-CENTERING. PROPELLER TORQUE, TRIM SETTING, WATER CONDITION AND BOAT SPEED AFFECTS THE STEERING. CONSTANT ATTENTION TO THE STEERING SYSTEM IS REQUIRED FOR SAFE OPERATION.**

BOARDING LADDERS

Your Cobalt is equipped with a boarding ladder. Never use the swim platform area and/or the boarding ladder while the engine(s) is running. The propeller(s) is very sharp and can cause bodily harm. Always make sure the boarding ladder is properly stowed and there is no one in the area behind the boat before starting the engine.

BASIC MANEUVERING

Wandering is a characteristic of all deep vee hulls at slow speed. There is no cure for wandering, however, a very basic operational technique can be applied which will minimize this characteristic. If the steering wheel is moved back and forth to compensate for wandering, invariably, the situation will be magnified. If the steering wheel remains in a centered position, the boat will wander back and forth slightly, however, the overall course of the boat will be a straight one.

PROPELLERS

Nothing is more important to the proper performance of your boat than the condition of the propeller(s). Even minor damage can adversely affect the boat's performance. Common symptoms of damage to propellers are a sudden drop in RPM, vibration or sudden loss of speed.

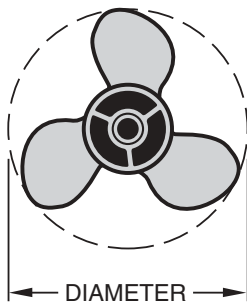

A propeller is measured by two dimensions: 1) the diameter, and 2) the pitch.

The diameter is determined by measuring the distance from the center of the propeller to the tip of one blade and multiplying that figure by two. Pitch is expressed in the number of inches a prop will advance in a solid medium in one revolution.

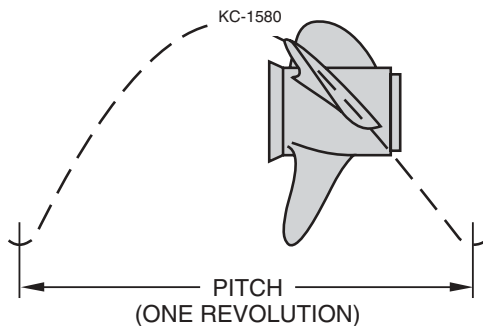

Operational characteristics of your boat, including its speed, may change due to several factors: atmospheric conditions; additions of extra equipment and accessories or passengers; marine growth on the bottom; and engine condition. Other factors include damage to the prop(s), tides, water temperature and direction of wind. Some of these factors are directly correctable by repair or maintenance. Others are beyond human control.



CAUTION

INCORRECT PROPELLER APPLICATION CAN CAUSE ADVERSE HANDLING CHARACTERISTICS. DO NOT CHANGE TYPE OR SIZE OF PROPELLER WITHOUT CONSULTING YOUR COBALT DEALER!



STAINLESS STEEL

Some Cobalts are standard equipped with stainless propellers. In this instance, do not substitute aluminum propellers. Adverse handling and top speed characteristics may be experienced.

PULLING POWER

If you need extra pulling power, you can obtain this by decreasing the pitch of your propeller(s) by two degrees. This will not endanger the engine or drive unit as long as the manufacturer's recommended top RPMs are not exceeded.

DRIVE UNIT TRIM

Trim angle is the angular relationship between the drive unit and the transom of the boat. Boat trim while underway greatly affects the performance and efficiency of your boat. For best results, the boat should be on plane and trimmed to reduce the amount of the boat's hull in the water (known as wetted surface). With less boat in the water, both speed and fuel economy increases. Continuous trim adjustment is required when operating your boat to maintain maximum performance and efficiency.

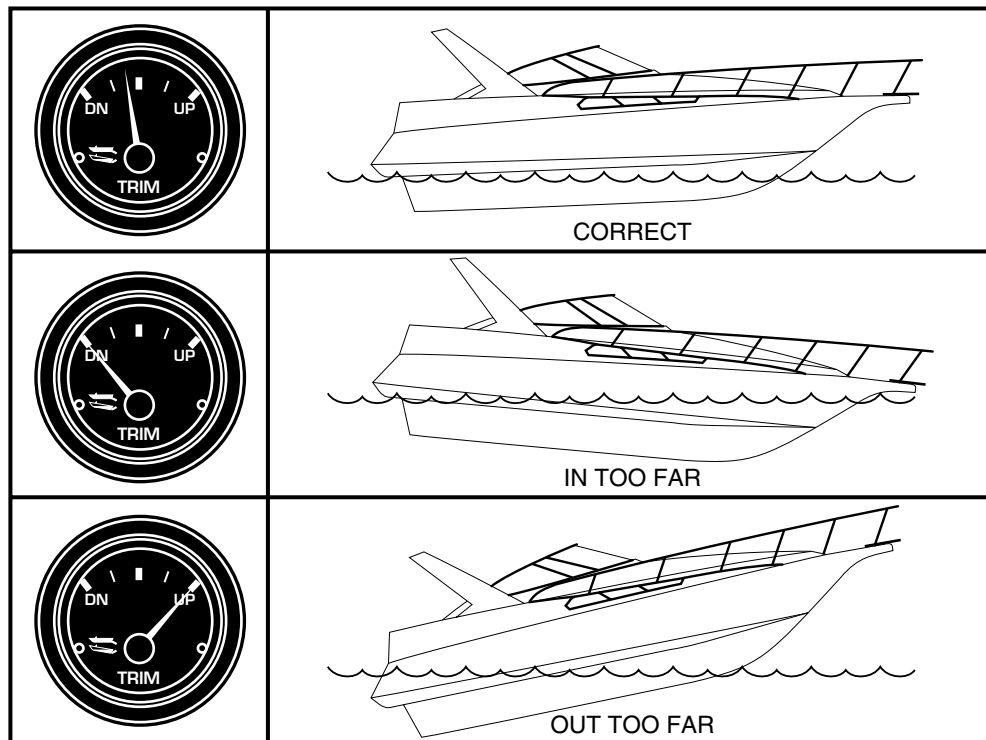

KC-1157

If the drive units are trimmed in too far (closer to the boat bottom), speed drops, fuel economy decreases and the boat may not handle correctly. However, it does provide better acceleration from a stand still; and because it forces the bow down, visibility is improved. If the drive units are trimmed out too far (away from the boat bottom), steering torque may increase, the boat may be difficult to get on plane, and may bounce.

To use power trim effectively, start with the drive units trimmed in. As the boat planes, increase the angle out. Experience is the best teacher for understanding proper drive trim.

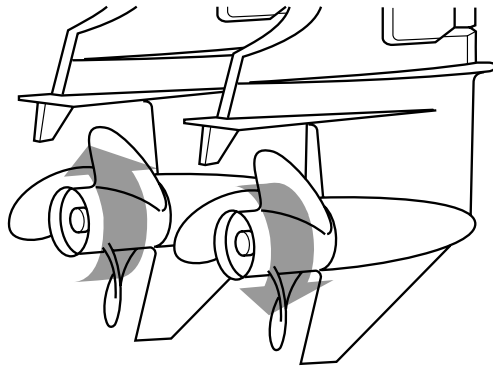

KC-2340

TWIN ENGINE OPERATION

Your Cobalt boat may be equipped with counter-rotating propulsion units. One unit will turn clockwise and the other unit will turn counterclockwise when operating. This concept balances the propeller torque which helps maintain an even keel.

Reverse thrust of the engines is used to slow and stop the boat. The boat's momentum will vary according to load, speed and water condition. Slow the engine speed to an idle, shift to NEUTRAL and pause, before shifting to REVERSE. Refer to your propulsion unit operator's manual for additional information concerning shifting.

When operating your Cobalt boat at low speeds, use propeller thrust to maneuver the boat, do not just turn the drive units. This enables you to maneuver in a smaller area and have more control of the boat. This technique is a combination of propeller direction, engine thrust and steering wheel maneuvers.

To make sharp and close quarter turns:

- Slow engine speed to an idle, shift to neutral and pause, then shift to reverse. This practice will help prevent damage to your drive units.
- Reverse the direction of the propeller on the side you want to turn. For example, if you want to turn starboard, shift the starboard engine into reverse. The forward speed of the port engine, along with the reverse rotation of the starboard propeller, will pivot your boat into a starboard turn.

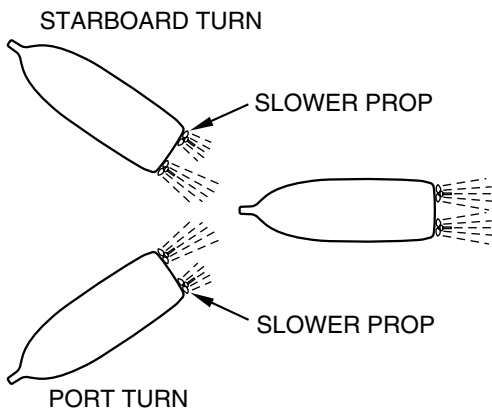

KC-1074 1074

- Practice using the throttle levers to control the boat. Try maneuvers in open water before attempting them near docks or other boats.
- Use a quick "burst" of your throttles to control the boat. Keep in mind that once the boat starts to move, momentum will carry through.

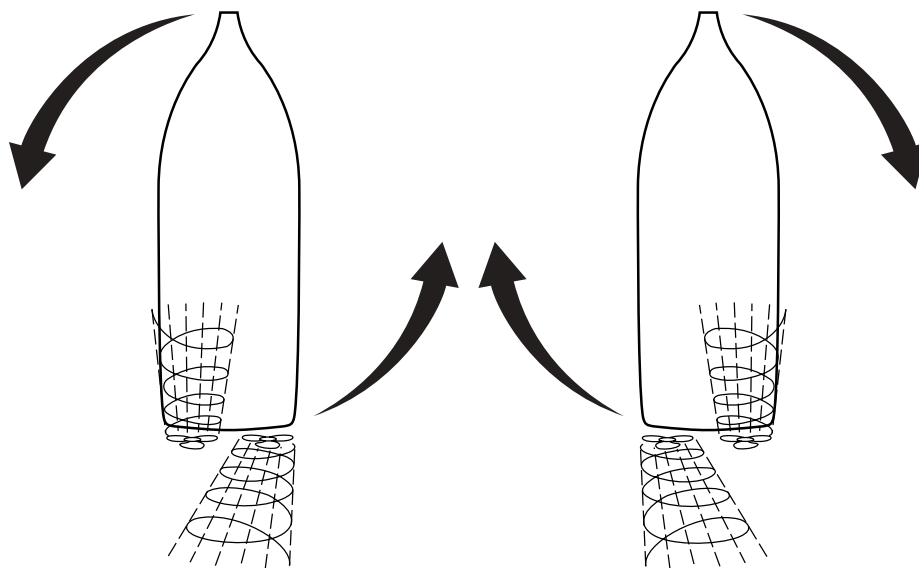

TWIN ENGINE MANEUVERING

KC-1521



It is best to learn maneuvering skills in open water away from traffic. Adequate practice is the only way to develop your boating skills.

LEAVING

Use caution when casting off. Wind, water conditions and other boat traffic will affect your boat's movement. Move slowly and:

- Be sure the engines are warmed-up before casting off.
- Have enough space between the boat and the dock to allow you to swing the boat's bow away from the dock. The boat's stern will move toward the dock as the bow moves away. Allow for enough room or the stern will hit the dock.
- Retrieve all mooring lines and fenders.
- Proceed slowly. Sound a long blast to alert other boaters that you are departing.

When leaving a mooring, you should already have enough space around the boat to maneuver. Untie from the mooring and move back slowly until you can see it. Proceed slowly while giving the buoy wide clearance.

While operating your Cobalt boat:

- Check gauges frequently for signs of abnormal behavior.
- Check steering, shift and throttle controls continue to operate smoothly.
- Check for excessive vibration.
- Monitor your fuel supply.
- Verify charging of the batteries.

RETURNING

Approach a dock slowly and use caution. Plan your maneuvers ahead of time. Allow wind and current movement to help maneuver your boat.



WARNING

DO NOT USE YOUR HANDS, ARMS OR ANOTHER PART OF YOUR BODY TO ATTEMPT TO KEEP THE BOAT FROM HITTING THE DOCK. THE BOAT COULD PUSH AGAINST THE DOCK, CAUSING SEVERE INJURY.

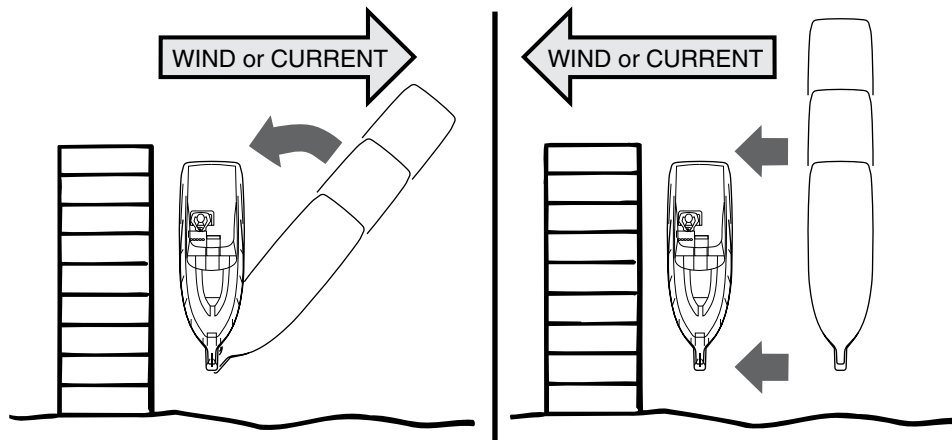

KC-1125



DOCKING

Follow these guidelines when docking:

- Come to a stop a short distance from the dock, then proceed slowly.
- Have your fenders, mooring lines and the crew ready.
- Observe how the wind and current are moving your boat. Approach the dock with the boat pointed into the wind, if possible. If the wind or current is pushing you away from the dock, use a sharper angle of approach. If you must approach the dock downwind or down current, use a slow speed and shallow angle. Be ready to reverse to stop and maintain position.
- If there is no wind or current, approach the dock at a 10° to 20° angle.
- If possible, throw a line to a person on the dock and have that person secure a bow line. If no one is on the dock, maneuver as close as you can, then secure any line to a piling or dock cleat.
- With the bow secure, swing the stern in using engine thrust, or pull it in with a boat hook.

APPROACHING A SLIP

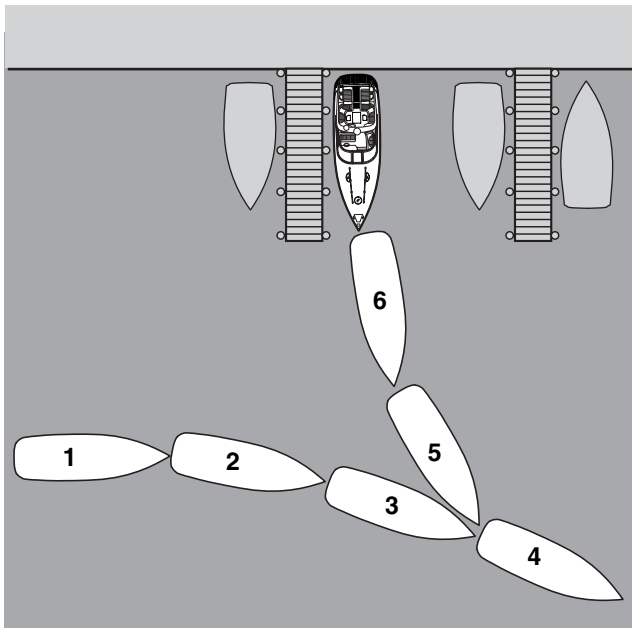

COB049C

This maneuver is similar to backing an automobile into a garage or parking space. When approaching a slip:

- Have fenders, mooring lines and the crew ready.
- Turn the boat's stern toward the slip.
- Shift to reverse.
- Maneuver slowly into the slip then shift to forward. Use your steering wheel and throttles to align the boat with the slip.
- Once aligned, shift to reverse and continue to back in slowly. Shift to forward when completely in to stop the movement of the boat.
- Shift to neutral, secure the mooring lines and stop the engines.

APPROACHING A MOORING

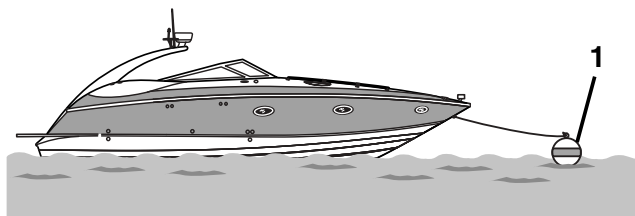

COB050C

1. Mooring Buoy

The only buoys you are permitted to moor to are mooring buoys. Mooring to a navigation buoy or other navigational aids or regulatory marker is illegal.

Approach a mooring buoy by heading into the wind or current. Observe the direction of other boats that already lie at mooring buoys. Since they are heading into the wind or current, approach your buoy at the same heading.



- When you think you can move enough forward without using your engines, shift to neutral.
- Have a crew member positioned on the bow with a hook to retrieve the mooring line. At that point, the crew member should be guiding your maneuvers toward the buoy.
- Turn off the engines after the mooring line is attached to the boat.

WATER SKI TOWING

Only the ski tow hook should be used for attaching one or more ski tow lines. Never attach ski tow lines to eyes or cleats.



WARNING

WHENEVER A SKIER OR SWIMMER IS CLOSE TO THE BOAT, SHUT OFF THE ENGINE TO PREVENT SERIOUS INJURY.



WARNING

THE SKI TOW CANNOT BE USED TO LIFT THE BOAT. IT CAN ONLY BE USED FOR WATER SKIING. IT IS NOT DESIGNED FOR TOWING ANOTHER BOAT OR FOR PARASAILING. THE TRANSOM MOUNTED EYES SHOULD BE USED FOR PULLING A HEAVIER LOAD.



CAUTION

THE STERN DRIVE UNIT HAS MANY SHARP EDGES, ESPECIALLY THE PROPELLER. EXERCISE CAUTION WHEN NEAR THE STERN DRIVE UNIT.

BOATING AT NIGHT

Boats operating between sunset and sunrise (hours vary by state) must use navigational lights, nighttime operation, especially during bad weather or fog can be dangerous. All “Rules of the Road” apply at night; it is best to slow down and stay clear of all boats, regardless of who has right-of-way.

Protect your night vision by avoiding bright lights and have a passenger, if possible, help keep watch for other boats, water hazards, and aids to navigation.

The size, speed, and direction of the other vessels are determined at night from the running lights. A green light indicates the starboard side of the boat, and a red light indicates the port side. Generally, if you see a green light, you have the right-of-way; if you see a red light, give-way to that vessel.



NOTE

Operate the boat between sunset and sunrise using your navigational lights. Navigational lights are legally required to indicate direction and right-of-way at night.



NAVIGATIONAL LIGHTS

You must use your navigational lights (running lights) when operating your Cobalt boat between sunset and sunrise, and when day time visibility is limited. Also, check with the local authorities before operating your boat for other requirements concerning the use of navigational lights.

The navigational lights are identified by a red light on the port side of the vessel, and a green light on the starboard side.

ANCHOR LIGHT

All boats at anchor must display a proper white anchor light. The anchor light must be visible 360 degrees and will remain on when operating the navigational lights.

Docking lights are to be used for docking only. It is illegal to use your docking lights while cruising.

HIGH SPEED OPERATION

When operating any boat at high speed, a great deal of caution must be exercised. This is particularly true during turns. Gradual turns can be completed at high speed by a competent driver, but, it must be emphasized that sudden turns at any speed and particularly at high speed can be especially dangerous. It is possible to throw passengers from their seats and even from the boat if caution is not exercised. Remember, common sense is the rule for safe boating.

We recommend that you should have ten hours of experience with the boat before any full throttle operation. Do not operate your boat until you are completely experienced with its handling characteristics. The following are some guidelines for performance operation.

- Keep bottom of the hull clean and free of barnacles and other growth. Growth on the hull can slow the boat down considerably.
- Prepare the boat. Be sure all gear is properly stowed and compartments are latched.
- Weight distribution affects performance. Keep weight in the boat to a minimum and evenly distributed.
- The propellers should be of the proper pitch to turn the recommended RPM rating for the engine with an average boat load. Refer to your propulsion unit operator's manual for additional information.
- Watch the tachometer. Keep the engines within the full throttle operating range. Refer to the propulsion unit operator's manual for full throttle operating range.



WARNING

- **MANEUVERABILITY ABOVE 50 MPH IS LIMITED. SUDDEN TURNS MAY CAUSE LOSS OF CONTROL.**
- **YOUR COBALT BOAT IS NOT DESIGNED FOR WAKE JUMPING. WHEN CROSSING ANOTHER BOAT'S WAKE, THROTTLE BACK TO PREVENT YOUR BOAT FROM LEAVING THE WATER. WAKE JUMPING IS VERY DANGEROUS. IT IS POSSIBLE FOR THE BOAT TO RE-ENTER THE WATER ON ITS SIDE, TRANSOM OR BOW. YOU AND YOUR PASSENGERS COULD SUFFER SERIOUS INJURY. ALSO, DAMAGE TO THE BOAT COULD TAKE PLACE CAUSING A HAZARDOUS CONDITION.**



High-speed operation on smooth water is very stable, but quick reactions and adjustments are needed to maintain control. Know your limits and stay within them. Keep one hand on the steering wheel and the other on the throttles; constant adjustments are necessary for rapidly changing conditions. Small inputs of throttle and steering movement are exaggerated at high speeds. Keep watch well ahead so that you have enough time to react.



WARNING

KEEP ONE HAND ON THE STEERING WHEEL AND THE OTHER ON THE THROTTLE CONTROLS AT ALL TIMES. IF THE BOAT BEGINS TO OPERATE IN AN UNSAFE WAY, PULL BACK ON THE THROTTLES. TRIM THE DRIVE UNITS IN AT THE SAME TIME. FAILURE TO MAINTAIN CONTROL COULD RESULT IN SEVERE INJURY OR DEATH.

ANCHORING

Use caution when anchoring. Look for signs of underwater pipes or cables. With the engines OFF, you have no control of the boat. Water and wind conditions will affect an anchored boat. Be sure the anchor will hold before leaving the boat.

There are many types of anchors available on the market. The choice of one anchor over another depends on many factors. An anchor will usually hold best in a mixture of mud and clay or in hard sand. A Danforth anchor is recommended for general boating. For more information on anchors, contact your Cobalt Dealer.

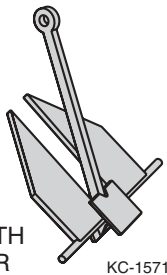

DANFORTH ANCHOR

KC-1571



WARNING

ANCHOR FROM THE BOW, NOT FROM THE STERN. A STRONG CURRENT CAN PULL A BOAT, ANCHORED BY THE STERN, UNDERWATER AND KEEP IT THERE.

LOWERING

All boats except the 240SD have an anchor storage compartment with a bitter end. The anchor on the 240SD can be tied off at the forward deck cleat or bow eye.

Head the boat into the wind or current over the spot where you want to lower the anchor. Spot the boat before lowering the anchor.

SETTING

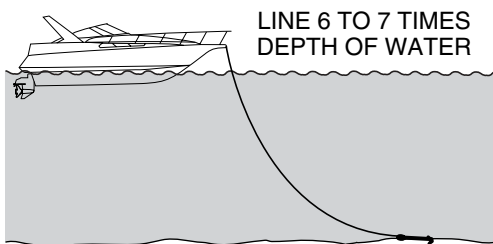

KC-1535.2

When the anchor hits bottom, slowly back up the boat, keeping tension on the line. Let out an anchor line that is 4 to 6 times the depth of the water. For example, if you are in 10 feet of water, let out 40 to 60 feet of line.

Occasionally check your position against the shoreline. If the anchor is dragging and you are drifting, reset the anchor.



WEIGHING

Start the engines and move forward until the anchor line is straight up and down. Pull hard to lift the anchor from the bottom material.

If the anchor is caught on the bottom, attach a line to the bow cleat so that it is taut. The up and down motion of the bow from wave action may lift the anchor from the bottom. If the anchor remains caught, let out a few more feet of line and attach it to the bow cleat. Slowly maneuver the boat around the anchor until the anchor pulls loose. Be sure to keep the line tight during this procedure.

TOWING

If seas are rough, it may not be easy to extend the tow line from one boat to another. In these cases, use a light throwing line with a weight on one end and with the heavier towing line secured to it.

Do not attempt to tow a much larger or grounded vessel. Because of the tremendous stress caused by towing, use a tow line that is rated at least four times the gross weight of the boat being towed. Tow ropes must be in good condition, free of any cuts or abrasions.

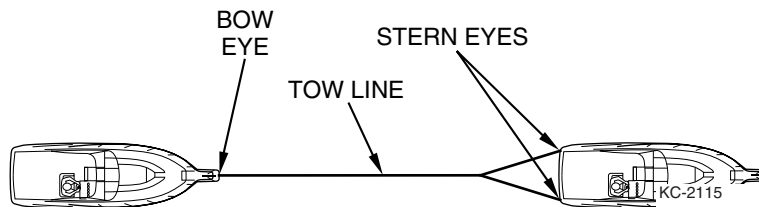

Attach the tow line to the bow eye on the disabled boat. Attach the opposite end of the bridle only to the stern eyes of the tow boat. Wrap the bridle with chafing gear where it rubs against the boat. Leave at least two boat lengths between the boats for adequate movement.

Adjust the tow line to match wave action. Keep the boats on the crest or in the trough of the waves at the same time. In protected, calm waters, shorten the line for better handling. Tow at moderate speed, allowing for adverse wind and wave conditions. Have the operator of the towed boat steer with you, if possible.

If you need a tow, or wish to tow another boat, use great care. The boat structure can be damaged by excessive pulling strain. You should offer help to a boat in trouble. However, towing a capsized, grounded or hull damaged boat is dangerous. Give assistance to the occupants; then call the proper authorities.



WARNING

WHEN TOWING, USE ONLY THE BOW AND STERN EYES; DO NOT USE CLEATS, HANDRAILS, ETC. DO NOT ALLOW ANYONE TO BE IN LINE WITH THE TOW ROPE. IF THE ROPE SHOULD BREAK OR PULL FREE, A DANGEROUS RECOIL COULD OCCUR RESULTING IN SEVERE INJURY OR DEATH TO ANYONE IN ITS PATH.

STOPPING ENGINES

Please refer to the propulsion unit operator's manual for stopping procedure information.



WARNING

DO NOT USE THE IGNITION SAFETY SWITCH AND LANYARD FOR NORMAL STOPPING OF THE ENGINES. DOING SO WILL IMPAIR YOUR ABILITY TO RESTART THE ENGINES QUICKLY OR MAY CREATE A HAZARDOUS SWAMPING CONDITION.



NOTE

If any problems are encountered during the outing, have your boat inspected by your Cobalt dealer and request any necessary repairs before your next outing.

DOCKING/LIFTING/STORAGE/TRAILERING

With fiberglass boats, severe gelcoat crazing or more serious hull damage can occur during launching, hauling and storage if pressure is created on the gunwales by the slings or improper use of the bow and stern eyes.

Bow and stern eyes should only be used for the following:

- To secure the boat to the trailer.
- Lifting the boat from the water to a trailer or cradle (26 feet and under)
- Lifting the boat from a trailer or cradle to the water (26 feet and under)

Prolonged lifting with the bow and stern eyes may cause stress on the fiberglass and gelcoat. The bow and stern eyes are not to be used for storage.

For overhead hoist storage and when lifting boats over 27 feet in length, use flat, wide belt-type slings and spreaders long enough to keep pressure from gunwales. Do not place slings where they may lift on underwater fittings and always place the aft sling under the engine area. Never lift a boat with a large amount of water in the bilge.

Your model Cobalt may designate where to place straps or slings via sling tags located below the gunwale on the hull sides. For more information, contact your Cobalt dealer.

A cradle or trailer is the ideal support for the boat whenever it is not in the water. Properly designed and constructed, it will provide support at the proper points, which is essential to avoid stress on the hull. Regardless of how you store your Cobalt in or out of the water, it is important to always keep the bow higher than the stern of the boat.



WARNING

CLEATS MUST NOT BE USED FOR LIFTING THE BOAT, THEY ARE INTENDED FOR THE MOORING/DOCKING USE ONLY.



WARNING

THE SKI TOW CANNOT BE USED TO LIFT THE BOAT. IT CAN ONLY BE USED FOR WATER SKIING. IT IS NOT DESIGNED FOR TOWING ANOTHER BOAT OR FOR PARASAILING. THE TRANSOM MOUNTED EYES SHOULD BE USED FOR PULLING A HEAVIER LOAD.



ENVIRONMENTAL CONSIDERATIONS

Using your boat in different environments requires special operating considerations.

SALT WATER

During long periods of mooring, if possible, tilt the propulsion units drives out of the water – except in freezing temperatures.

Fresh water flushing of the engines is recommended after operating in salt, polluted or brackish water. Refer to your engine operator's manual for additional information.

FREEZING TEMPERATURES

When boating in temperatures below freezing, keep the propulsion units drives tilted down (submerged) at all times. This will prevent damage from freezing.

Upon removing your Cobalt boat from the water, leave the drive units in the vertical position until cooling system has drained. Refer to your propulsion unit operator's manual for additional information.

Use caution when handling clear vinyl canvas in low temperatures to prevent damage from cracking.





VINYL INTERIOR AND UPHOLSTERY CARE

The vinyl fabric in your Cobalt's interior has been especially selected to take the tough punishment of the elements and hard usage of an active boater. Avoid sharp objects that may cut or tear your vinyl.

The vinyl in your Cobalt has been coated with PreFixx protective finish. It's designed to be cleaned easily, over and over, without showing signs of wear. With PreFixx protection, it is possible to remove stains that could never be removed before. There are three families of sunscreen ingredients which may contribute to the staining of the vinyl in your Cobalt.

- Aminobenzoic acids - e.g. PABA
- Hydroxy benzophenones - e.g. Oxybenzone
- P-methoxycinnamic acid - e.g. Octyl methoxycinnamate

This list should not be considered inclusive, although it does represent a large selection of sunscreens which are known to stain vinyls, even treated with PreFixx. In actuality, almost any sunscreen with a high percentage - two percent or above - of active ingredients is a potential stainer.

Special care should be taken to prevent dark colored rubber products from coming in contact with the vinyl upholstery. The optional mooring cover comes with black rubber straps and these straps could stain the vinyl permanently.

CARE AND CLEANING OF VINYL

DAY-TO-DAY SOIL

Remove ordinary dirt and smudges with a mild soap and warm water solution. Dry with a soft, lint-free cloth or towel. For more difficult stains, use of a stronger detergent is recommended; provided the detergent manufacturer's instructions are followed closely.

SPECIAL CLEANING PROBLEMS

The following steps are recommended to clean stains on PreFixx-protected vinyl upholstery. Many difficult stains can be removed when these cleaning agents are used in the following order.



NOTE

It is extremely important to clean the stained area as quickly as possible, making sure the recommended cleaning steps are followed in order.



STEP 1 CLEANERS

- Formula 409™, Fantastik™.
- Clorox™ Soft Scrub® with bleach.
- Household cleaners and bleaches. Rinse cleansed area with fresh water and dry with a clean cloth.

STEP 2 CLEANERS*

Solvent-type cleaner to be liberally applied with a cloth, damp sponge or fine bristle brush.

- Rubbing alcohol (isopropyl alcohol).
- Lighter fluid (naphtha). Rinse cleansed area with fresh water and dry with a clean cloth.

STEP 3 CLEANERS

Strong, active cleaners to be applied with a soft cloth or damp sponge. Use no more than six rubs; if stain persists, contact manufacturer. Dry with another cloth, then rinse with clear water and dry.

- Nail polish remover (acetone/water).

**RECOMMENDED CLEANING SOLUTIONS
FOR PREFIXX-COATED NAUTOLEX VINYL**

<u>STAINING AGENT</u>	<u>CLEANING STEP</u>
Spray paint	1 - 2 - 3
Ballpoint pen	1 - 2 - 3
Lipstick	1 - 2 - 3
Yellow mustard	1 - 2 - 3
Bird droppings	1 - 2 - 3
Crayons	1 - 2
Eye shadow	1 - 2
Oily spot	1 - 2
Petroleum Products	1 - 2
Coffee	1
Tea	1
Hair oil tonic	1
Blood	1
Urine	1
Grape juice	1
Olive oil	1
Chocolate	1
Ketchup	1
Baby oil	1



WARNING

FLAMMABLE LIQUIDS ARE EXTREMELY DANGEROUS AND SHOULD BE USED ONLY IN WELL VENTILATED AREAS. AVOID OPEN FLAME OR SPARK.

DARK STORAGE AREAS

Often, when a boat is stored completely covered or in a dark building, the vinyl will darken or become “dingy” looking. If this happens, simply place the boat in direct sunlight for a few hours and the vinyl will brighten up.



LEATHER CARE

FOR SPOTS AND SPILLS

Wipe up excess liquid immediately with a clean absorbent cloth or sponge. If necessary, use clean luke warm water only and let air dry naturally. If water is used, clean the entire area where the spot occurred. An example would be the entire seat cushion or entire arm. Do not dry wet areas with hair dryers, etc.

FOR STUBBORN SPOTS AND STAINS

Use a mild non-detergent cleaner such as a bar of Ivory soap or Amway L.O.C. Apply the soap to a clean wet sponge, wash, then rinse well. Let air dry naturally.

FOR BUTTER, OIL OR GREASE

Wipe excess butter, oil or grease off the leather with a clean dry cloth, then leave it alone as the spot should dissipate into the leather in a short period of time. Do not apply water or try to wash a butter, oil or grease spot.

DO NOT USE

Saddle Soap, cleaning solvents, furniture polish, oils, varnish, abrasive cleaners, soaps or ammonia water.



NOTE

1) *These are recommended or suggested methods of cleaning, but the manufacturer is not responsible for damage incurred while cleaning.* 2) *Always try the cleaning method in a hidden area first to test the results.*

VACUUMING

A very effective and easy way to keep your interior ship shape is giving it a good vacuuming. The vacuum cleaner allows you to reach in tight areas such as under the bow, and other storage areas. It's also a great way to clean up any debris in the bilge area.

CARPET CARE

The carpet in your Cobalt is made of the finest materials available. Scrubbing with soapy water will handle most tough jobs. A simple hosing for mild cleanups will bring out that new look. Thoroughly air dry before reinstallation into your boat. Your dealer can suggest methods of cleaning difficult stains in your carpet.

FIBERGLASS FINISH CARE

The finish on your Cobalt is known as gelcoat. The gelcoat used by Cobalt is the finest available on the market today. With all its properties, it is not impervious to the elements and many types of water conditions.

The best way of taking care of your gelcoat finish is with prevention and proper care.

A multi-purpose boat soap* should be used to clean exterior fiberglass/gelcoated surfaces on your Cobalt after each use. This product, depending upon the ratio mixed, is designed to clean anything from dirty hull and decks to greasy engines. Always rinse and wipe off the finish with a damp towel or chamois.

A fiberglass restorer/wax* should be used to remove heavy oxidation, characterized by chalky/faded surface as well as rust and exhaust stains. This product will not only remove the oxidation but also leaves a wax protection on the cleaned surface in one easy application.



Paste wax* will help retard the UV light damage. We suggest three coats be applied at the end or the beginning of the season, depending on the type of winter boat storage (covered, enclosed storage facility), and again mid-season.

To extend the life of your gelcoat finish, Cobalt recommends the use of marine canvas duck mooring covers totally covering the top deck of the boat for maximum protection. Additionally, if your boat is to be stored where the sun is constantly on the side or transom of the boat, you should consider having some custom skirting made to compliment the mooring cover. Tonneau covers, although supply adequate short term protection to the interior, will not protect the gelcoat finish. Please check with your Cobalt dealer for further information on this subject.

*3M carries a complete line of fiberglass care products.

STAINLESS STEEL TRIM AND HARDWARE CARE

Cobalt engineers strive to ensure the brightwork and hardware on your boat is made of the highest finish quality materials available within the design/function envelope. Continuing research identifies, tests, and evaluates new materials and products as they become available. Upgrades are made when added value to the customer is proven.

“Stainless steel” is actually a grouping of steel alloys that employ base materials such as nickel, chromium, and molybdenum in varying portions. Each blend possesses different characteristics in terms of strength, durability, finish quality, and rust and corrosion resistance. These materials are used to produce parts that are cosmetically superior to regular carbon steel, are rust and corrosion resistant, yet retain favorable physical properties for functional uses. Cobalt utilizes the highest finish quality material appropriate to the exacting structural requirements of each application.

CORROSIONX

One of the issues associated with owning a boat is corrosion, which, ironically, is often caused directly by the marine environment. If you operate a boat in salt water, you will be impressed with the rapid growth of corrosion in just a few weeks.

Since we recognize that your purchase of a Cobalt Boat was a major financial decision, we want you to be happy about your choice for years to come. After consulting with our dealers and operators throughout the country, we found that regular applications of a product called CorrosionX will keep your boat operating at peak efficiency, free of corrosion. To assist you, we have included a small can of CorrosionX in the optional salt water kit. Minimally, it should be applied to the following areas and components in the time frames specified:

TOPSIDE

Spray or wipe a light coat of CorrosionX on all rails, stanchions, cleats, cleat bolts and other metal fixtures/fittings up on deck. Treat hinges, locks, closure mechanisms and sliding tracks of doors and windows. If sprayed on, wipe with cloth to remove excess. A very light coat is all it takes and it should be applied every two months if operating in salt water and every four months in freshwater operations.



INSIDE THE BULKHEAD

Once a year, spray electrical connections, fuse panels, antenna bases, etc. Light sockets should be treated at two or three month intervals. Every six months, treat plumbing connections in the galley and head areas. Once a year, apply to hinges, locks and sliding tracks of doors and windows to keep them properly lubricated and functioning smoothly.

OTHER AREAS

Treat hydraulic cylinder shafts for steering and other operating mechanisms once a month. Spray the entire engine, including engine mounts, every six months. Treat the bilge pump housing and connections plus other items in the bilge area once every three months. Thru-hull fittings and seacocks should also be treated every three months. Fuel line fittings at the fuel tank should be treated every six months.

CorrosionX is a multi-functional product with universal application. A good rule of thumb: if it rusts or corrodes, if it needs lubricating or if it's rusted shut and needs to be broken apart, it's a potential application. If you have any questions about CorrosionX, check the manufacturer's web site: <http://www.corrosionx.com> or call 800-638-7361.





ERECTING CANOPY TOP

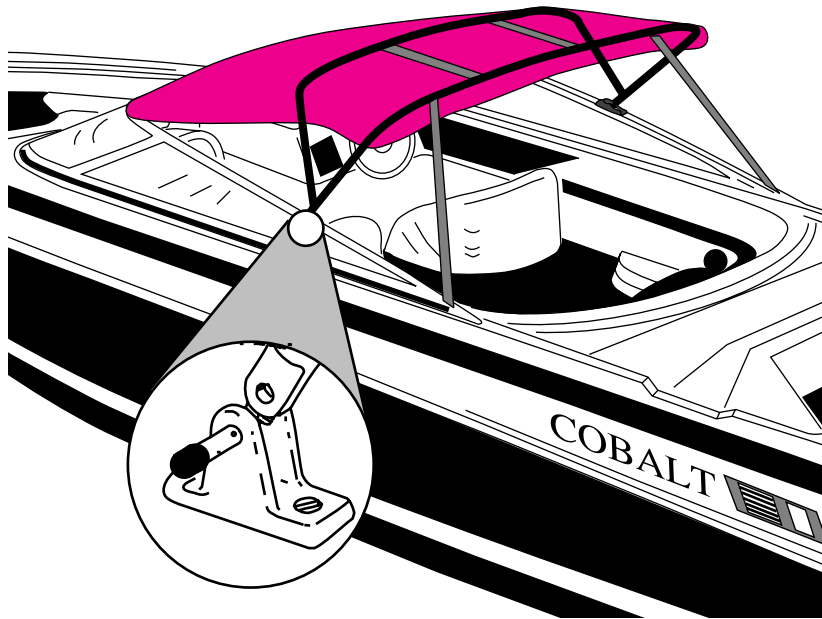

COB173

1. Remove canopy top assembly from "top storage area."
2. Attach top bow ends to top mounts on each side of the boat. Use quick disconnect pins.
3. Remove storage boot and unroll canopy top.
4. Open frame and snap front of canvas to windshield.
5. Snap the straps to the eyelets on the windshield frame or deck.
6. Adjust straps for tight fit.

SIDE CURTAINS & STERN CURTAIN – OPTIONAL

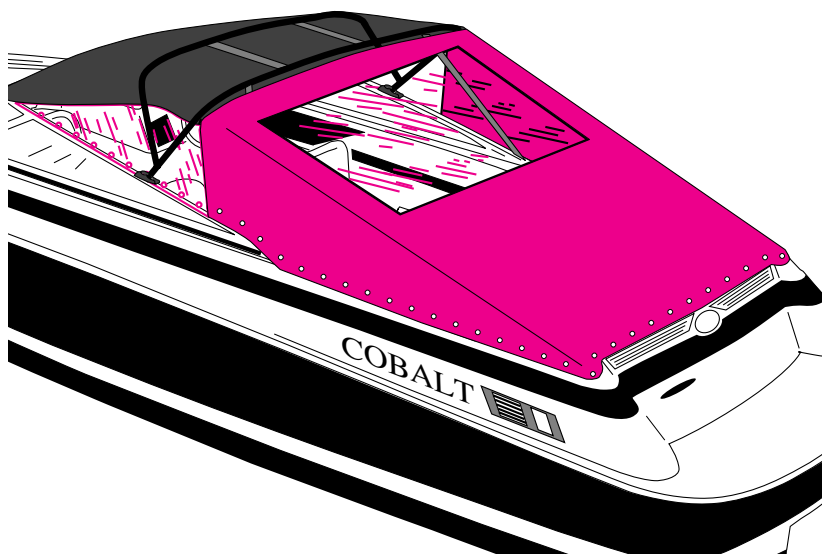

COB174

1. Zip the side curtains to the top.
2. Snap curtains to windshield and deck.
3. Zip the stern curtain to the canvas top, snap the curtain to the deck, starting at the center rear of the curtain and working forward evenly.



BIMINI TOP - OPTIONAL

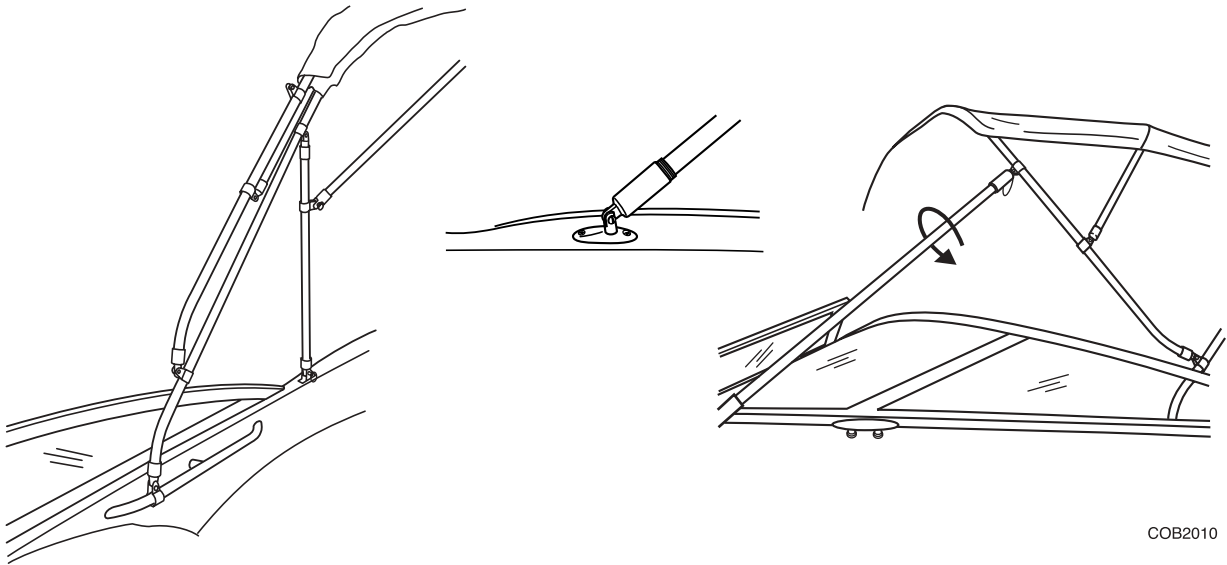

COB2010

200/220

1. Remove the stainless adjustable arms from storage area.
2. From its stowed position, raise the bimini top and install the aft support legs and secure with the pins first, then remove the canvas bimini boot and secure cross member supports with the pins.
3. Unfold the top and install the stainless adjustable arms (tensioners) into the quick disconnect fittings on the deck forward of the windshield. Secure the forward arms to the forward cross members with the pins.
4. Tighten the bimini by twisting the tensioners.
5. Trailer and store the bimini top in the stowed position in its canvas boot.

226/240/246/262/263

1. Remove canvas boot, unroll and extend bimini canvas. Fasten forward straps to eyelets forward of windshield on the deck. Adjust straps for tightness.
2. Store in the upright position for both trailering and storage.

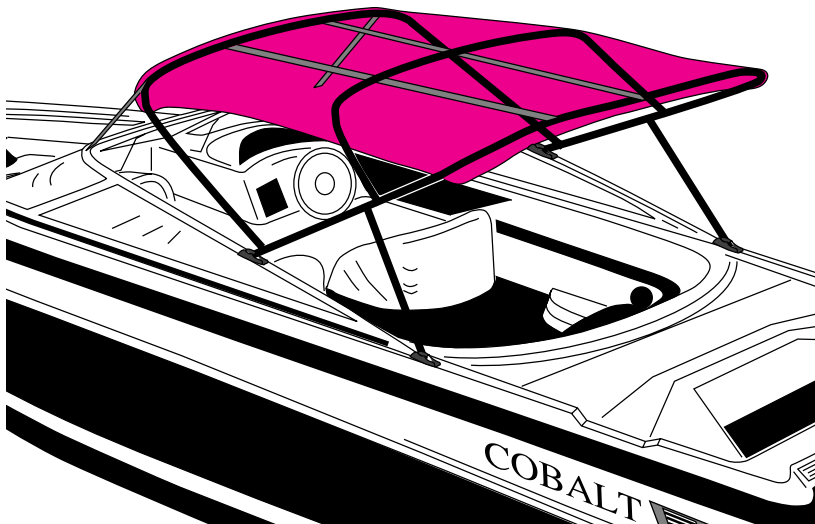



DANGER

THE BIMINI TOP MAY BE SUSCEPTIBLE TO DAMAGE FROM WIND VELOCITY IN EXCESS OF 35 MPH. DAMAGE COULD OCCUR RESULTING IN POSSIBLE INJURY TO THE OCCUPANTS OF THE BOAT.

282

1. Remove canvas boot, unroll and extend bimini canvas. Install stainless adjustable arms to the top mounting points on the forward bimini bow and to the quick disconnect fittings on the deck forward of the windshield. Turn leg adjusters for tightness.
2. Store in the upright position for both trailering and storage.

293

1. Remove canvas boot, unroll and extend the bimini canvas.
2. Remove the front legs from storage area and fasten to forward bimini bow.
3. Release pushpins on aft support legs and extend legs by pushing forward on the bimini top.
4. With the bimini top this position; attach the forward legs to their respective fittings on the mounts located on the windshield.
5. Pull bimini top aft to compress the rear legs to their original locked positions.
6. Store in the upright position for both trailering and storage.

240 TOWER WITH SUNSHADE INSTRUCTIONS

To install remove the large knurled knobs from the tower. Position the sunshade under the tower and reinstall the knobs. Position support rods with thumbscrews on the front forward tower legs. Reverse procedure to remove.



NOTE

Before operating the boat at high speeds, ensure the pushpins are fully inserted into the securing knobs on the sunshade attachment.



WARNING

DO NOT TRAILER YOUR COBALT WITH THE SUNSHADE INSTALLED ON THE TOWER.



200/220 SS ARCH WITH BIMINI INSTRUCTIONS

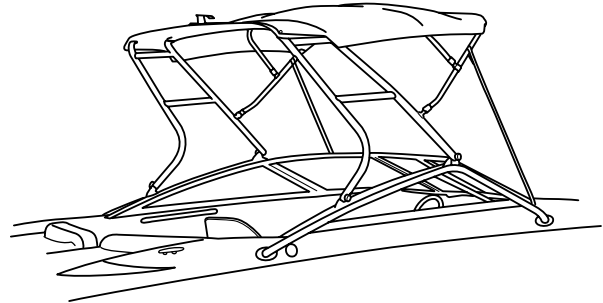
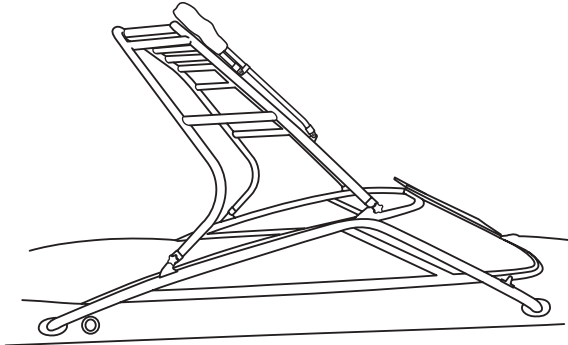

COB2011

To set up bimini from stored position, unsnap the retaining strap snaps and unzip the canvas boot. Attach bimini top to the arch using the snaps. Unfold the top forward and install the tension straps into the quick disconnect fittings on the deck forward of the windshield.

Trailer and store the bimini top in the stowed position in its canvas boot.

282 SS ARCH WITH BIMINI INSTRUCTIONS – FORWARD BIMINI

To set up bimini from stored position remove pins from the end fittings that hold the bows to the front of the arch. Unzip the canvas boot from the bimini and arch and swap the bimini end-for-end. Re-attach the bow ends to the fittings on the top of the windshield using the pins provided. Zip the aft edge of the bimini to the forward tubing of the arch. Install the two forward support bars and tighten the bimini by twisting the tensioners.

282 SS ARCH WITH BIMINI INSTRUCTIONS – AFT BIMINI

Unzip the bimini boot and extend the aft bimini. Attach clips to eye fittings on aft tubing of arch and tension straps. Enclosure zips in similar to other enclosures.

BIMINI ENCLOSURE – OPTIONAL 226/246/262/263/293

Your bimini is equipped with zippers to accept a bimini enclosure. This enclosure is made of Sunbrella canvas and isinglass. To install, simply zip the front, sides and aft curtain to the bimini top and snap to the provided snaps on your deck and windshield. It is recommended to roll your isinglass pieces for storage to prevent cracking. Refer to page 60 of this manual for proper care guidelines.



DANGER

BIMINI ENCLOSURES MAY BE SUSCEPTIBLE TO DAMAGE FROM WIND VELOCITY IN EXCESS OF 25 MPH. DAMAGE COULD OCCUR RESULTING IN POSSIBLE INJURY TO THE OCCUPANTS OF THE BOAT.



CAUTION

IF THE CANVAS COMES IN CONTACT WITH ANY UPHOLSTERY, THE CANVAS COLOR COULD TRANSFER. IT IS SUGGESTED TO KEEP THE UPHOLSTERY AND CANVAS SEPERATED, ESPECIALLY IF THE CANVAS IS WET.



BOW TONNEAU COVER – OPTIONAL (BOWRIDERS ONLY)

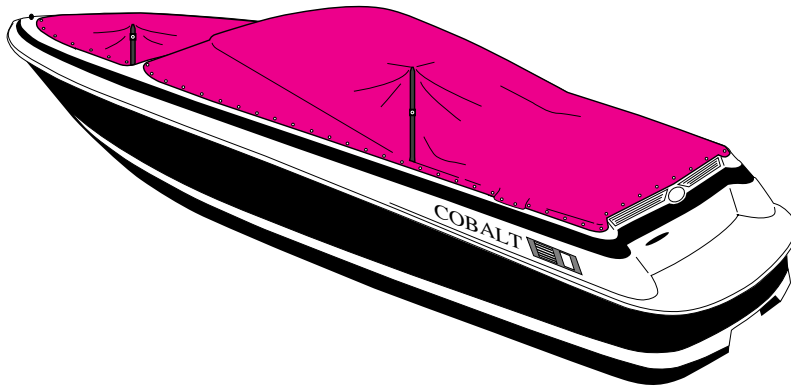

1. Open walk-thru doors.
2. Starting at bow and working aft, snap cover to boat.
3. Close windshield center door and snap the canvas to the underside of the door.
4. Install the adjustable tonneau cover pole adjust to “tent” the cover.
5. Walk-thru doors may be closed if desired.

COCKPIT TONNEAU COVER – OPTIONAL

1. Unroll cover and snap to the deck starting at the center of the windshield. Snap to the forward outside edge of the windshield only.
2. Install tonneau support pole to underside of cover (just in front of rear seat) with snap and adjust pole to approximate height of windshield. Some models have two support poles.
3. Snap aft end of cover to back deck starting in center and working outboard (note: you may have to readjust the support pole for proper fit).
4. Continue snapping up sides.

MOORING COVERS - OPTIONAL

Cobalt mooring covers are made from 100% SharkSkin™ polyester. Mooring covers are recommended by Cobalt for any storage longer than a few days. Mooring covers are not recommended for trailering because they cannot be tied down tightly enough in trailering conditions to keep them from moving on the gelcoated fiberglass surface. This movement can damage the gelcoat causing a dullness or even scratching.



NOTE

For storage, we recommend an optional mooring cover made of 100% SharkSkin™ polyester that will properly protect the gelcoat finish on the deck of your Cobalt. Do not use canopy tops, side curtains, aft curtains, tonneau covers, etc., for long term storage. These tops were not designed for long term storage. Adequate ventilation is questionable and mold/mildew may form. For more information on appropriate covering for long term storage, please see your Cobalt Dealer.



STOWAGE OF THE CANOPY – 226/246

The following is the recommended procedure for storage of the top:

- a. Disconnect the straps from the side of the boat and allow them to hang free.
- b. Disconnect the top snaps from the windshield. (At this point, the two bows should still be separated.)
- c. Grasp the bows and fold them together. (Allow the canvas to gather between the bows.)
- d. Roll the canvas around the bows. (As you roll the canvas, assure its tightness and pull the side of the canvas to prevent wrinkling.)
- e. Slide the boot over the canvas and zip.
- f. Remove the top from the top mounts and stow the top in the “top storage area.”



NOTE

If the canvas was stored when wet, it may have shrunk slightly making it hard to pull tight.

If this happens, two people may have to pull at the same time to close the support legs.



NOTE

Make sure all canvas is completely dry before storage to prevent mildew.

COBALT CANVAS CARE

CARE, CLEANING AND GENERAL INFORMATION

The boat top and other canvas items supplied on your Cobalt boat are manufactured from top quality materials to provide you with years of trouble free service. The following information on the care, cleaning and proper storage of the fabrics and fasteners that make up your marine canvas is being provided to help you maintain the appearance and ease of operation. We will also explain the performance characteristics you should expect from your canvas.

SUNBRELLA FABRIC

This is a woven fabric made of 100% solution dyed acrylic fiber. It is very colorfast and will withstand long-term exposure to the sun (ultra-violet) without excessive fading or deterioration.

CLEANING INSTRUCTIONS

Fabric should be cleaned regularly before substances such as dirt, roof particles, etc., are allowed to accumulate on and become embedded in the fabric. The fabric can be cleaned without being removed from the installation. Simply brush off any loose dirt, etc., hose down and clean with a mild solution of natural soap in lukewarm water (no more than 100 degrees Fahrenheit). Rinse thoroughly to remove soap. **DO NOT USE DETERGENTS.** Allow to air dry. For heavily soiled fabric, remove the top from frame. Soak the fabric in a solution that has been mixed to the following proportions: 1/2 cup of Clorox and 1/4 cup of Ivory Snow, Dreft or Woolite per each gallon of lukewarm water. (The water should be no more than 100 degrees Fahrenheit.)



Allow the fabric to soak until the bleach has killed the mildew and the stains can be brushed out with a common kitchen scrub brush. Rinse the fabric thoroughly in cold water to remove all of the soap. This may require rinsing several times. Incomplete rinsing can cause deterioration of sewing threads and prohibit the fabric from being properly retreated. Allow the fabric to air dry completely. Sunbrella may also be dry cleaned. **DO NOT STEAM PRESS OR DRY IN ELECTRIC OR GAS DRYER.** Sunbrella is thermoplastic or heat sensitive. Excessive heat can damage and shrink the fabric. This method of cleaning may remove part of the water and stain repellancy that was applied to the fabric during its manufacture. The fabric should receive an application of an air-curing treatment such as “303 HIGH TECH FABRIC GUARD.”



CAUTION

UNDER NO CIRCUMSTANCE ARE THESE FABRICS TO BE PUT IN HOT WATER. UNDER NO CIRCUMSTANCE ARE THESE FABRICS TO BE RUN THROUGH THE HOT DRYING CYCLE OF AN AUTOMATIC DRYER. FABRIC SHOULD BE LINE DRIED. UNDER NO CIRCUMSTANCE ARE THESE FABRICS TO BE STEAM PRESSED AT A DRY CLEANER.

CHARACTERISTICS

Sunbrella is a woven fabric. Even though it is treated with a water repellancy, some “misting” through the fabric is typical.

With new canvas, the greatest potential for leakage is through the sewn seams. Because Sunbrella and the long-term thread that’s used are synthetic, the holes created by sewing will not swell up and seal when exposed to water as cotton does. Usually, the movement of the fabric in use will move the fibers enough to seal the holes. You may apply a few light coats of “303 HIGH TECH FABRIC GUARD” to speed up the process.

When the canvas is new, the fit will normally be tight. It is designed this way because Sunbrella stretches as it ages. The initial tight fit allows for a suitable fit for the life of the canvas.

The fit with Sunbrella will vary slightly in the heat, cold and rain.

CARE

- NEVER store canvas wet or in an unventilated, moist area.
- Always roll the canvas instead of folding. This is of particular importance on side curtains or any part with the clear vinyl “glass.”
- Roll the top carefully around the bows and cover with the storage boot provided.
- Handle the clear vinyl carefully. It is soft and very prone to scratching.
- Your Top, Side Curtains and Aft Curtain are designed and intended for short-term use only. **DO NOT** use for storage.
- Under no circumstances should the boat be towed with the boat top in the upright position.



OTHER CANVAS COMPONENTS

CLEAR VINYL “ISINGLASS”

The clear vinyl “isinglass” used in side curtains, aft curtains and visors is very reactive to heat and cold. Be careful unrolling the vinyl in cold weather to prevent cracking. Keep vinyl side curtains from touching the bows (tubing) to prevent burning the vinyl. If boat is stored with top, side curtains and aft curtain in place, heat build up inside of the boat may discolor the vinyl.

Cleaning: Using a soft cloth, clean with a solution of Ivory or Lux soap, liquid or flakes, and lukewarm water. Allow to air dry. Never use any type of abrasive cleanser, as it will scratch the glass. To keep the vinyl soft and flexible, regularly apply UV screening agent such as “303 PROTECTANT.”

ZIPPERS

When zippers are new, they can be a little difficult to zip. Zip carefully without forcing. They will loosen with use. A zipper lubricant may be used to help new zippers as well as maintaining long trouble free service. The most vulnerable part of the zipper is the starts. Use care when starting zipper to prevent damage.

SNAP FASTENER

Fasteners should be unsnapped as close to the button as possible. Never remove canvas by pulling roughly on one edge of the material. This can damage the canvas as well as the fasteners. If the snaps become difficult to unsnap, use lubricants such as Vaseline, Chapstick, WD-40, silicone spray, etc. The most common recommendation is to rub candle wax or paraffin around the stud or inside the socket. Whichever method is used, care must be taken so that the lubricant does not stain the canvas or other surfaces it may contact.



VIII TECHNICAL INFORMATION

ENGINE OPERATION/MAINTENANCE/SERVICING

Included with your owner's packet is your engine manual(s). This manual was prepared by the engine manufacturer and contains information concerning the operation and care of your engine. Please read this manual thoroughly and become acquainted with this information.

It is advisable to maintain a service log to record service checks, such as oil changes, so you can determine when it's time for servicing. A maintenance log is also required when requesting warranty using the extended warranty supplied with your new Cobalt.

THE BREAK-IN PERIOD

We cannot stress enough, the importance of reading your engine manual(s) and following the manufacturer's instructions for breaking-in your engine(s).

WINTERIZING AND OFF-SEASON STORAGE

Store your Cobalt with the bow slightly elevated; i.e., the same attitude as if the boat were floating at rest. Remove the transom drain plug. If the boat is stored with the bow down, moisture will not be able to move to the engine bilge area and out of the boat. Mold and mildew may form as a result of the inability of moisture to escape. Store all bow cushions in the open position and open all storage areas.

Preparing for winter lay up is important. In frigid zones, be particularly attentive to items that can be damaged by freezing. Freeze damage is not covered by warranty.

The following systems require winterization:

ENGINE

WATER SYSTEM

Consult your Cobalt Dealer for information about this procedure.

HOT WATER HEATER

Consult your Cobalt dealer for information about this procedure.

AIR CONDITIONING

Consult your Cobalt Dealer for information about this procedure.

GENERATOR AND MUFFLER

Consult your Cobalt Dealer for information about this procedure.

TOILET SYSTEM

Consult your Cobalt Dealer for information about this procedure.

COCKPIT HEATER - OPTIONAL

To winterize, remove the two 5/8 inch cockpit heater hoses from the engine. Pump antifreeze into one hose until entire heater system is filled.



Good storage is very important whether indoors or outdoors. Boat trailers designed for specific model boats provide excellent support for your Cobalt for long term storage. If you are storing your Cobalt by some other means; rack, hoists, blocks, etc., consult your Cobalt Dealer. Your dealer can assist you in making sure your boat has proper support.

It is very important the proper canvas is used as designed. The canvas listed in items 1 and 2 are made of Sunbrella, an acrylic material. Acrylic does not breathe as well as polyester, therefore all moisture cannot escape the boat when covered. The mooring cover listed in item 3 is made of 100% Sharkskin™ polyester.

1. Canopy Top, Side Curtains, Stern Curtain, Bimini Top

Day or Night Boating

Not designed for storage use

2. Bow Tonneau, Cockpit Tonneau

Trailerling

Overnight Protection

Not designed for storage use

3. Mooring Cover

Storage - short or long term

If a temporary poly cover, such as shrink wrap, is used, provide adequate ventilation to prevent mold or mildew.

Remove battery. Store on a wooden shelf or wood base. Store in a dry, covered place, charged to capacity. Check it periodically during the off-season. Recharge monthly.



WARNING

BATTERY ACID CAN CAUSE BLINDNESS IF SPLASHED IN EYES, BURNING OF SKIN AND SEVERE GASTROINTESTINAL DAMAGE IF INGESTED. AVOID CONTACT WITH BATTERY ACID. USE EXTREME CAUTION.



FUEL REQUIREMENTS

The fuel line between the fuel tank and the fuel inlet of the engine is made of a synthetic, flexible material and although it is the best material available, alcohol can deteriorate it, especially during periods of storage. For this reason, it is suggested you have your Cobalt dealer inspect this fuel line at least annually and replace, if necessary.

Fuel level indicator system is designed to provide quick response to fuel level. Therefore, some oscillation of the fuel gauge needle is normal during operation.



WARNING

YOUR FUEL SYSTEM SHOULD BE CHECKED BEFORE EACH OPERATION. AT LEAST ONCE A YEAR, HAVE YOUR FUEL SYSTEM THOROUGHLY CHECKED BY A CERTIFIED COBALT SERVICE TECHNICIAN. GASOLINE IS HIGHLY FLAMMABLE; EXTREME CAUTION SHOULD BE USED AT ALL TIMES.

CIRCUIT BREAKERS

Most electrical standard equipment devices are controlled with circuit breakers. These breakers will activate if overloaded and cut power to the switch. To restore power, simply push the breaker button in and release. (Breakers do not require fuse replacement).

FUSES

Some electrical components have in-line fuses in them. Check the failed component for the possibility of an in-line fuse if a tripped circuit breaker is not found.

IN-LINE FUSE COMPONENTS:

- Depth Sounder 1 amp (located behind dash)
- Air/Water Temperature Gauge 1 amp (located behind dash)
- Telescoping Anchor Light 4 amp (located at light)
- Trim Tab Control 20 amp (located behind dash or breaker used on dash)
- Stereo 10 or 20 amp (breaker used on dash)
- Bilge Pump Power Pickup 30 amp (located at battery switch)
- Amp Power Pickup 30 amp (located at battery switch)
- Bilge Pump #2510 15 amp (located behind dash)
- Bilge Pump #1000 5 amp (located behind dash)
- Sump Pump* 5 amp
- Tank Level Monitor System* 4 amp
- CO Monitor* 1 amp
- Head Blower* 3" 5 amp
- Head Blower* 4" 8 amp

*Fuses are located behind the cabin electric panel



LIGHTING/BULB REPLACEMENT

EXTERNAL LIGHTS

Bow Light Bulb(s)	#71
Stern Light Bulb	#1004
Telescoping Stern Light	#PL 1280X
Arch	#212-2

INTERNAL LIGHTS

Open Bulb Utility Light	#1004 or #211
Cuddy Cabin Reading Light	#MR16
Black Rectangular Courtesy Light	#1044-99A
Chrome Courtesy Light (Round)	#90
Overhead Console Light	GE 912
Dome Light	#211
Ice Chest	#194

INSTRUMENT LIGHTS

Tachometer	194 SF2
Speedometer	194 SD2
Voltmeter	658 S11
Oil Pressure	658 SH2
Temperature	658 SC2
Fuel	658 SC2
Trim	658 SC2

WET LOCKER DRAINING

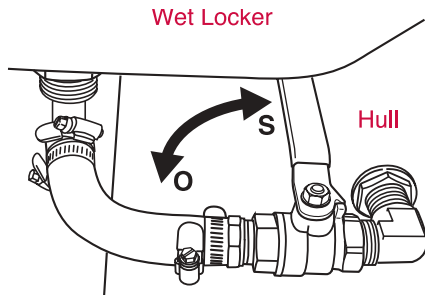

COB0003

Your Cobalt wet locker may be equipped with a seacock to drain water away from the boat which can accumulate in the wet locker.

Turn the valve lever located in the engine compartment, under the wet locker, to drain.

BATTERY CONNECTIONS

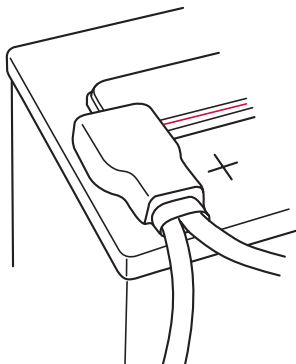

COB004

Read and understand the safety information on or supplied with your battery(s).

Maintain the batteries following the manufacturer's recommendations.



WARNING

KEEP THE BATTERY CONNECTIONS CLEAN, TIGHT AND INSULATED TO PREVENT SHORTING OR ARCHING AND CAUSING A POSSIBLE EXPLOSION. INSTALL PROTECTIVE COVERS AND CHECK THE CONNECTIONS OFTEN TO MAKE SURE THEY ARE CLEAN AND TIGHT.



STEREO EQUIPMENT

Your Cobalt boat is equipped with an AM-FM CD player and may have been accessorized to enhance its fidelity. For additional operating information, refer to the operator's manual.

MARINE TOILET (HEAD) AND OPTIONAL MACERATOR

HEAD OPERATING INSTRUCTIONS

Before operating the head for the first time, read the owner's manual for the marine toilet.

ELECTRICALLY OPERATED HEAD

1. Open the inlet water seacock below the cabin floor.
2. If overboard discharge is to be used, make sure the "Y" valve is in the overboard position, and the macerator seacock is open.
3. To charge the head, depress the foot pedal on the lower left side of the bowl, and push the flush button. Release the flush button after the bowl is moistened, and then pump the floor pedal 2-4 times to fill the bowl with water.
4. To flush, depress the foot pedal and push the flush button at the same time – hold until all waste is removed.

MANUALLY OPERATED HEAD

1. Open the inlet water seacock.
2. Pump the floor pedal 2-4 times to fill the bowl with water.
3. To flush, depress the foot pedal and operate flush handle next to head at the same time. Operate handle until all waste is removed.



NOTE

To empty the bowl of excess water, operate flush button until water level decreases to desired level.

The marine toilet (head) allows you to hold the waste in a holding tank. The waste can then be pumped out through a deck plate fitting marked "WASTE."

The optional macerator system allows the discharging of waste water directly overboard through a seacock. The seacock's valve must be opened to allow activation of the macerator pump switch. For additional operating information, refer to the macerator operator's manual.

Some Cobalt boats are equipped with a head (marine toilet) and waste containment system. The head has either the manually operated system, or the electrically operated system, which draws seawater in through the hull to flush waste water from the marine toilet. The toilet pumps the waste water into a holding tank.



If the boat is fitted with a waste holding tank, it is emptied through the deck plate fitting marked “WASTE.” Waste is pumped from the head through a sanitary waste hose to the top portion of the tank. A sanitary waste hose is attached to the bottom of the tank, and runs to the dockside pumpout plate. An overboard vent keeps the tank at atmospheric pressure regardless of waste levels.

All the components of the waste system are made of materials specially formulated to prevent odor permeation. It is strongly recommended you regularly add chemical to your tank by flushing it through the head. The chemical helps to control odor and break down the waste. Follow the manufacturer’s instructions on the chemical before using.



CAUTION

DO NOT FLUSH INTO A FULL HOLDING TANK. ATTEMPTING TO FLUSH THE HEAD WHEN THE TANK IS FULL COULD RESULT IN DAMAGE TO THE WASTE SYSTEM.

A waste tank level monitor may be installed to provide a visual indication of the amount of waste in the tank. Refer to individual model for more information.

WASTE DISPOSAL

Dockside Pumpout – This system directs all waste to the holding tank. To clear the tank of waste water, you will need to use the dockside pumpout services provided at marinas or other facilities.

To empty the tank of waste, a suction hose is connected to the pumpout plate and to the dockside pump.



CAUTION

OVERBOARD DISCHARGE OF WASTE SHOULD ONLY BE USED IN APPROVED AREAS. IT IS YOUR RESPONSIBILITY TO COMPLY WITH LOCAL REGULATIONS REGARDING THE DISCHARGE OF WASTE.

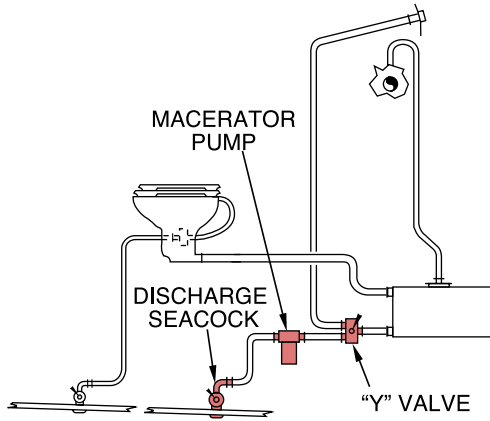

TYPICAL MACERATOR SYSTEM

KC-2046

MACERATOR PUMP

A “Y” valve is installed between the pumpout plate and the macerator discharge seacock. The macerator pump is located between the “Y” valve and the macerator discharge seacock. In this configuration all waste is flushed from the head to the holding tank. The “Y” valve permits you to use the dockside pumpout feature, or to use the macerator to pump the waste from the holding tank overboard.

To pump out the holding tank using the macerator pump:

1. Open the discharge seacock.
2. Move the “Y” valve lever to the down or overboard position.



CAUTION

DO NOT RUN THE PUMP DRY. RUNNING THE PUMP WHEN THERE IS NO WASTE TO PUMP OUT OF THE HOLDING TANK WILL SHORTEN THE LIFE OF THE PUMP.

3. Activate the macerator pump by turning its switch “ON.”
4. Close the macerator discharge seacock and turn macerator pump “OFF” after the pumpout is complete.





VIII TROUBLESHOOTING

IGNITION SAFETY SWITCH

Your Cobalt is equipped with an ignition safety switch located on the lower lip of the dashboard. Make sure the lanyard is installed with the switch holding the lanyard in place. Please consult your Cobalt dealer.

AIR HORN – 262/263/282/293

If air horn does not produce any sound or is low in volume, check the following:

1. Check to see if the 20A fuse has blown.
2. Check the air hose for kinks that could impede airflow.
3. Check the wiring for broken or frayed wires. Check the compressor with a DC voltmeter. Make sure there is 12 volts across the two compressor terminals while the horn button is being pushed.
4. Check the horn diaphragm. Remove the 5 Phillips head screws on the horn end cap and remove the plastic diaphragm. Inspect the diaphragm for contamination. If there is dirt or oil on it, clean with a soft dry cloth and re-install. In the unlikely event the diaphragm is torn, call AFI customer service, 707-226-9600, for replacement part #20147.
5. Check compressor lubrication. It is important to lubricate the compressor every 4 to 5 months. If the compressor has not been lubricated on a regular basis it could lose air volume.
6. To lubricate the compressor, remove the air hose from the compressor air port and place 3-4 drops of light machine oil into the air port opening. Do not over lubricate. Let the oil set for a few minutes and then activate the compressor momentarily to distribute the oil. Failure to activate the compressor before re-connecting the air hose may result in oil being blown onto the horn diaphragm and contaminating it. Re-connect the air hose.

For additional information contact your Authorized Cobalt Dealer.



NOTE

The air horn has a compressor that requires lubrication every 4-5 months. See your Authorized Cobalt Dealer.



WARNING

**WHENEVER CHECKING FOR ELECTRICAL PROBLEMS USE EXTREME CAUTION.
GASOLINE IS FLAMMABLE!**



WARNING

GASOLINE IS FLAMMABLE. USE EXTREME CAUTION WHEN HANDLING GASOLINE!

STARTER WON'T CRANK ENGINE

Ignition switch inoperative - see Authorized Cobalt Dealer.

Throttle position - Check to see that remote control is in start or neutral position. Change position of throttle only slightly.

Dead battery - Check level of electrolyte, disconnect battery. Charge battery.

Battery connections loose or corroded - Check for loose connections and corrosion. Clean connections and tighten.

Starter connections loose - Check connections and tighten. If solenoid clicks when attempting to start engine, check battery connections. If condition persists, see your Authorized Cobalt Service Dealer.



WARNING

BATTERY ACID CAN CAUSE BLINDNESS IF SPLASHED IN EYES; BURNING OF SKIN AND SEVERE GASTROINTESTINAL DAMAGE IF INGESTED. USE EXTREME CAUTION.

ENGINE RUNS ERRATICALLY

See your Authorized Cobalt Dealer.



WARNING

GASOLINE IS FLAMMABLE. USE EXTREME CAUTION.

Fuel pump malfunction - Check operation of pump. See your Authorized Cobalt Dealer.

Fuel tank vent and line plugged - Check for restriction in line and vent. Blow out line and vent.

ENGINE VIBRATES

Propeller condition - Check for bent, broken or damaged propeller. Check for weeds on propeller or gear case.

Spark plug condition - Check spark plug electrodes and ceramic. Clean and regap. Replace plugs, if necessary.

High tension leads loose or deteriorated - Insure all connections are clean and tight. See Authorized Cobalt Dealer.

ENGINE RUNS BUT BOAT MAKES LITTLE OR NO PROGRESS

Fouled or damaged propeller - Stop and shut off engine. Check for weeds on propeller, bent or broken propeller. See your Authorized Cobalt Dealer.



PERFORMANCE LOSS

Throttle not fully open - Check to see that throttle opens fully at engine.

Improper fuel - Fill tank with correct fuel.

Overheating - Immediately turn off the engine and contact your Cobalt dealer.

Boat overloaded - Reduce load.

Boat trim - Distribute boat load evenly.

Improper propeller selection - Select proper propeller pitch and diameter. (See chart in owner's manual or consult your Cobalt Dealer).

Excessive bilge water - Check for excessive water, drain bilge.

Boat hull condition - Clean if marine growth is present.

FUEL INJECTION ENGINES

Fuel injection engines have safety circuitry built in that monitors many different functions of the engine and drive system. In many of these engines, a malfunction that the operator may not be aware of, can trigger a safety circuit in the engine causing it to automatically slow down and run rough. Should such a circumstance occur, please check with your Cobalt dealer as soon as possible.

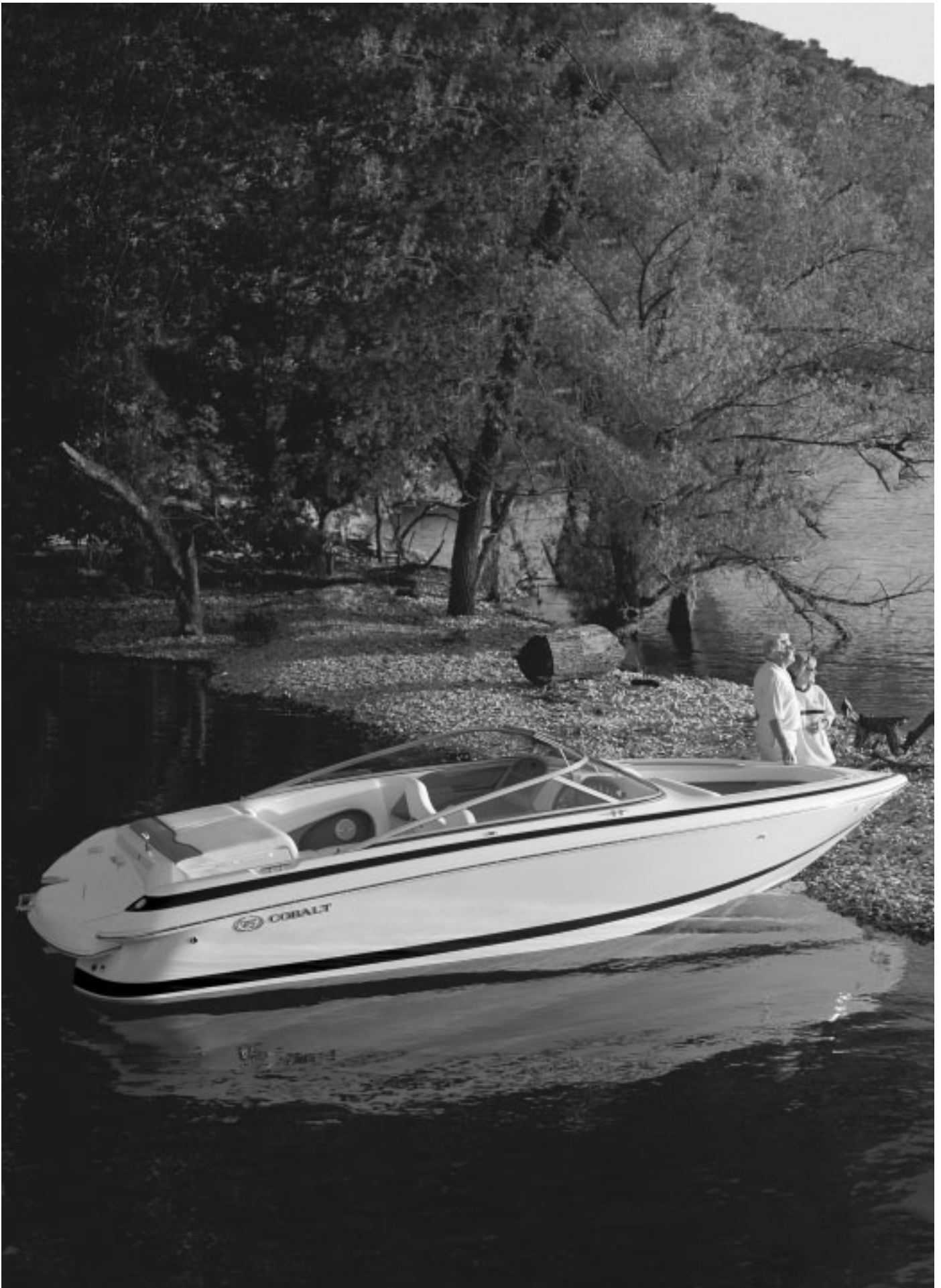



MODEL SPECIFIC INFORMATION

COBALT BOATS - OWNER'S MANUAL

LAYOUT AND SPECIFICATIONS

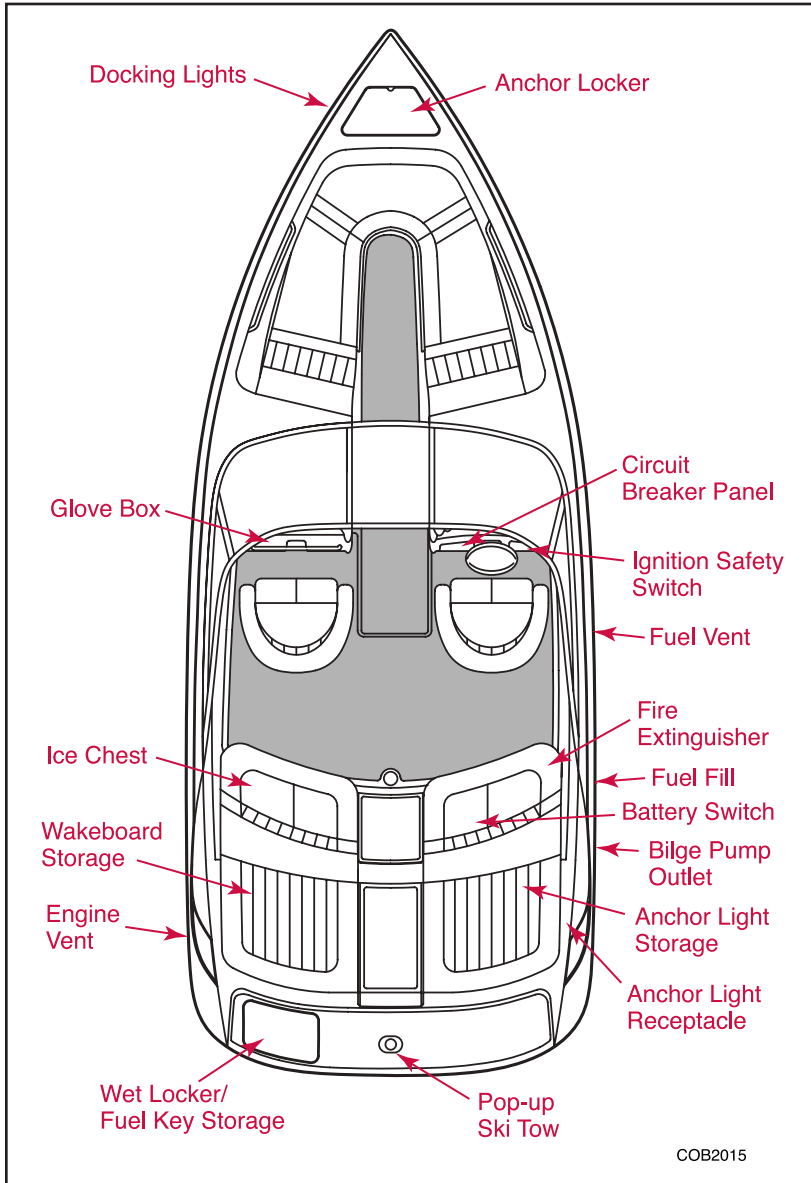

SPECIFICATIONS

StyleBowrider	
Centerline20' 4"	(6.20 m)
Centerline w/ext.		
Swim Platform22' 4"	(6.81 m)
Beam8' 6"	(2.62 m)
Dry Weight3800 lbs.	(1724 kg)
Deadrise20°	
Fuel Capacity40 gal.	(151 l)
Draft (drive up)24"	(61 cm)
Draft (drive down)36"	(92 cm)
Freeboard, forward33"	(84 cm)
Freeboard, aft34"	(86 cm)
Bridge51"	(1.3 m)
Bridge Clearance		
w/Tower101"	(2.6 m)
Trailer Height6' 10"	(2.1 m)
Trailer Height		
w/Tower10' 5"	(3.2 m)
Capacity, weight1600 lbs.	(726 kg)
Capacity, persons10	

COB2015



CAPTAIN'S CHAIR ADJUSTMENT AND OPERATION

Your captain's chairs have the flip-up position for greater visibility and maneuverability while docking. You can sit on the raised cushion or stand in front of the cushion. Standing while driving your boat should only be done while maneuvering at an idle by an experienced driver.

The chairs are adjustable fore and aft and also rotate.

Rotation - Loosen the "T" handle next to the pedestal under the seat. Raise the lever on the opposite side of the pedestal. Rotate the seat to the desired position and lower the lever and tighten the knob to tighten the seat. Do not allow the seat to swing freely.

Fore and Aft adjustments - A handle under the front lip of the seat when raised allows the seat to move. Make sure the mechanism is properly engaged to prevent seat movement while the boat is underway.

SWIVEL CHAIRS ADJUSTMENT AND OPERATION – OPTIONAL

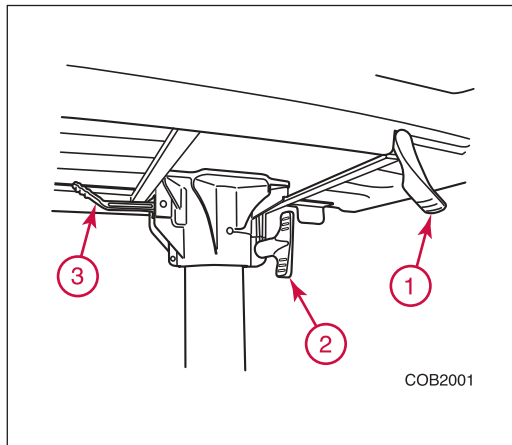

Your optional swivel chairs have the capability to rotate for convenience when moored or docked and for the passenger to spot a skier when skiing.

Both chairs rotate and are adjustable fore and aft.

1. Lift lever to adjust fore and aft.
2. Turn rotation friction handle clockwise to increase friction and counterclockwise to decrease friction. The chair should always be operated with slight friction.
3. Rotation lever for chair - move chair slightly forward, then lift lever to rotate. The lever will rest in its detent when the seat is in its forward direction.



WARNING

DRIVING WHILE STANDING UP IS AN EXTREMELY HAZARDOUS PRACTICE. DO NOT DRIVE WHILE STANDING AT SPEEDS GREATER THAN "IDLE SPEED."



CAUTION

ALL SEATS MUST BE IN A LOCKED/SECURED POSITION WHILE THE BOAT IS UNDERWAY.



INSTRUMENT PANEL

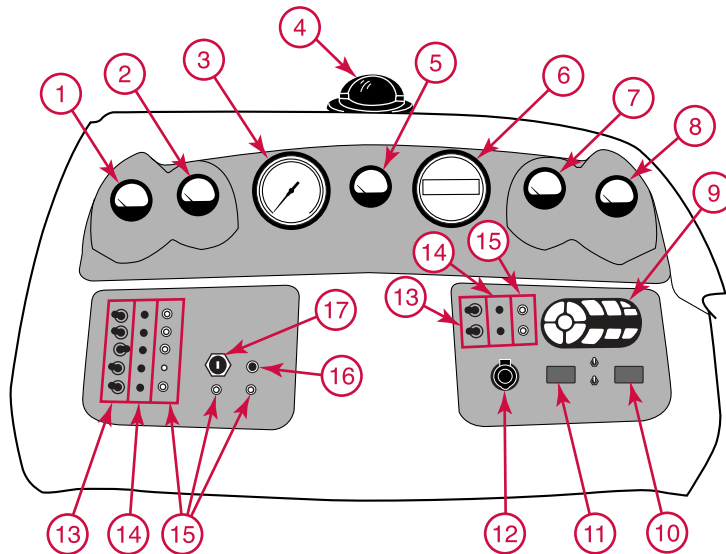

COB2002

1. Temperature Gauge - Temperature may fluctuate slightly while running. Maximum temperature may vary depending on type of engine.
2. Oil Pressure Gauge - Pressure can vary according to type of engine. It is normal for a hot engine to have low pressure at idle, (depending on type of oil, pressure may drop as low as 10 PSI at idle).
Please consult the engine owner's manual supplied with your boat concerning the oil pressure the engine in your boat should attain.
3. Speedometer (Miles Per Hour)
4. Compass - optional
5. Fuel Gauge - shows approximate amount of fuel remaining in tank.



WARNING

SHOULD WATER TEMPERATURE REACH 180 DEGREES FAHRENHEIT, YOUR ENGINE IS OVERHEATING AND SHOULD BE CHECKED IMMEDIATELY FOR PROBABLE CAUSE.

6. Tachometer - (Revolutions Per Minute) or Optional Perfect Pass.
7. Voltmeter - shows the condition of charge in the battery. It only indicates while the ignition is in the "ON" position. With the engine at idle or not running, it may show as low as 10 to 12 volts. With the engine running at cruising speeds and above, it should show 12 to 14 volts.
8. Trim Gauge - Shows the position of the drive unit in reference to the bottom of the boat.
9. Stereo Remote Control (optional)
10. Air/Water Temperature Gauge - Moving the toggle switch below the gauge allows you to go between air and water temperature readings. The gauge will display AIR and WATER to indicate which temperature source is in use.
11. Depth Sounder - Your Cobalt is equipped with a depth sounder. To see your options - shallow, deep, keel depth and units - toggle switch to down position. To set each option to desired reading toggle switch to up position. Consult your Cobalt Dealer for further information.
12. 12V Accessory Receptacle
13. Two Position Switch - Controls equipment as labeled.
 - NAV/ANC - Three Position Exterior Light Switch NAV. position - navigation (running) lights, bow light and stern light. Center position - off. ANC. position - stern light only. This switch will also activate the optional telescoping anchor light, if equipped.
14. On/Off Indicator Lights



- 15. Circuit Breakers - Push to reset if necessary. If the button continues to pop out, consult your Authorized Cobalt Dealer.
- 16. Horn Button - The horn, itself, is located under the deck.
- 17. Ignition Key Switch



WARNING

NEVER OPERATE YOUR BOAT AT NIGHT WITHOUT ALL OF THE REQUIRED LIGHTS OPERATING. THIS INCLUDES BOW LIGHT AND REMOVABLE STERN LIGHT. MAKE SURE LIGHTS ARE NOT BLOCKED BY CANVAS OR OTHER OBSTACLES.

EXTENDED SWIM PLATFORM / BOARDING LADDER

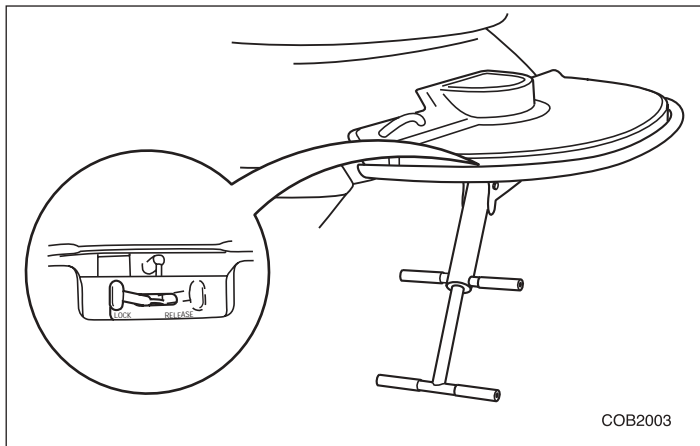

The swim platform was designed for use by people – not for the storage of personal equipment. Maximum platform weight capacity is 800 pounds. If the swim platform is removed, the boat will not pass Coast Guard inspection, and the boat cannot be boarded until a boarding ladder is installed. The swim platform may be removed for off-season storage only.



WARNING

EXTENDED SWIM PLATFORM MUST BE ATTACHED WHILE BOAT IS IN USE TO AVOID POSSIBLE INJURY OR DROWNING. SWIM LADDER IS ATTACHED TO THE PLATFORM. REMOVABLE FEATURE IS FOR BOAT STORAGE ONLY.



WARNING

DO NOT OCCUPY EXTENDED SWIM PLATFORM WHILE ENGINE IS RUNNING OR ENGAGED. PROPELLER CONTACT MAY CAUSE SEVERE INJURY OR FATALITY. ALL GASOLINE POWERED ENGINES PRODUCE CARBON MONOXIDE (CO). CO IS COLORLESS, ODORLESS, AND DANGEROUS. DIRECT AND PROLONGED EXPOSURE TO CO WILL CAUSE BRAIN DAMAGE OR DEATH.

LADDER MUST ONLY BE USED WHILE THE ENGINE IS OFF. (See warning label section.) Be sure the ladder is raised and secured prior to starting engine. Exercise caution while using the ladder.

Use the release lever to release the ladder and telescope to full length. Lift ladder to retract and stow. Place release lever in the LOCK position. Use caution when stowing the ladder to prevent pinching fingers.



WARNING

DO NOT USE BOARDING LADDER WHILE ENGINE IS RUNNING.



CAUTION

THE STERN DRIVE UNIT HAS MANY SHARP EDGES, ESPECIALLY THE PROPELLER. EXERCISE CAUTION WHEN NEAR THE STERN DRIVE UNIT. ALWAYS MAKE SURE THE BOARDING LADDER IS PROPERLY STOWED AND THERE IS NO ONE IN THE AREA BEHIND THE BOAT BEFORE STARTING THE ENGINE AND ENGAGING THE SHIFT MECHANISM.

WINDSHIELD HOOK

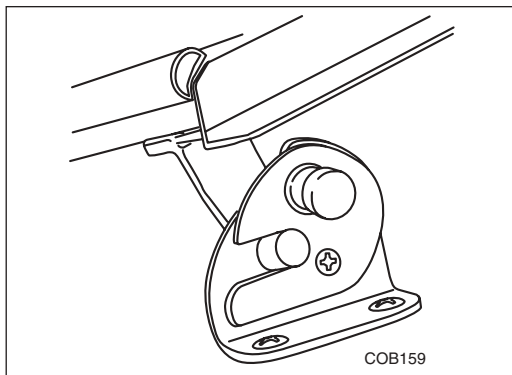

To open the windshield make sure the vertical slots in the mechanism are aligned. Swing the windshield open until the windshield post falls into the vertical slots and the mechanism locks.

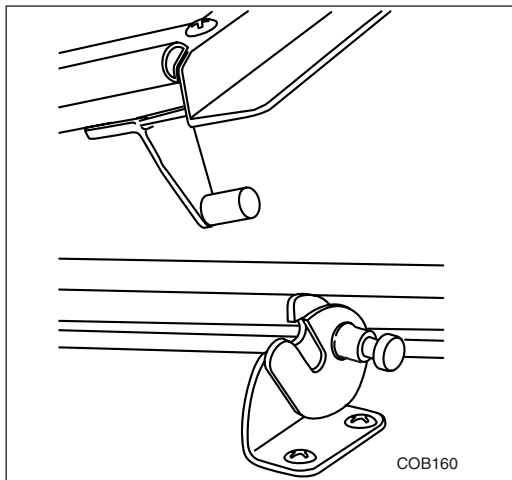

To close the windshield release the locking mechanism by pulling the forward-facing button. Swing the windshield into place.



AFT WALK-THRU FILLER CUSHIONS – OPTIONAL

The starboard rear walk-thru area can be converted into a large sundeck pad over the motor box by installing aft filler cushions. Snap the cushions in place.

BOW CUSHION INSERT – OPTIONAL

The bow area can be converted into a sundeck by inserting the bow cushion insert.

POP-UP SKI TOW

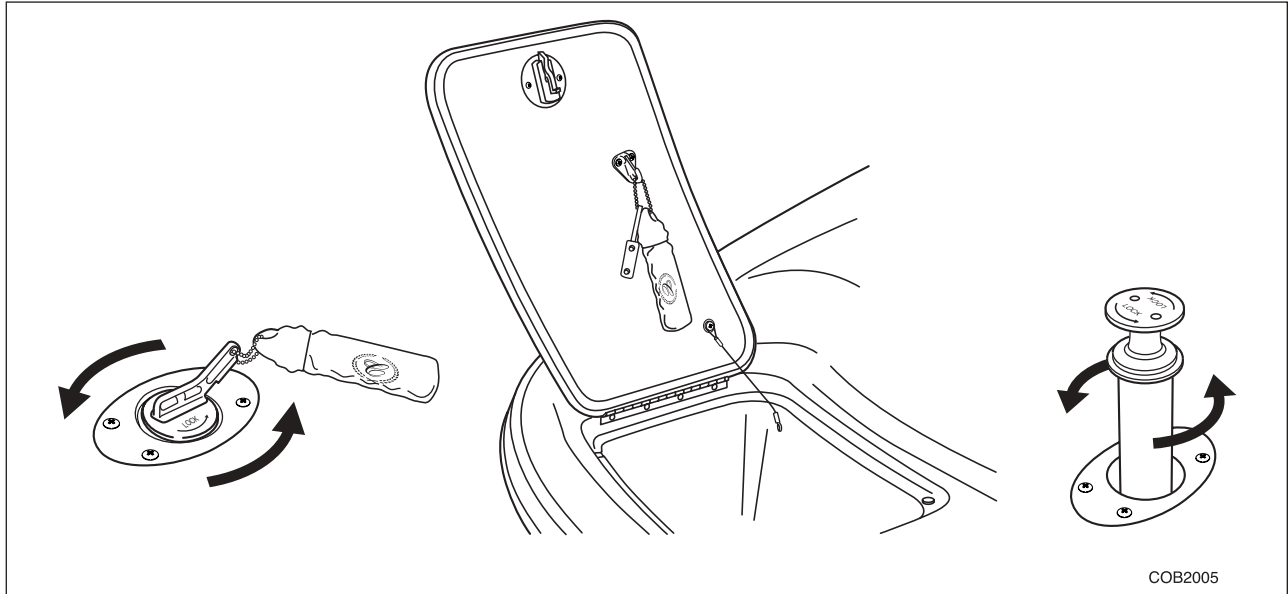

The stainless steel pop-up ski tow is designed for concealment as well as function.

- Using the fuel cap key, turn the ski tow counterclockwise to pop-up.
- Lift up and continue to turn counterclockwise to lock into position.
- To stow, turn clockwise to lower and using the key, press down and continue to turn clockwise until it is in its locked position.

Use the key storage clasp inside the wet locker for convenient key storage.



DANGER

THE POP-UP SKI TOW IS DESIGNED FOR A SINGLE SKIER ONLY.



TELESCOPING ANCHOR LIGHT – OPTIONAL

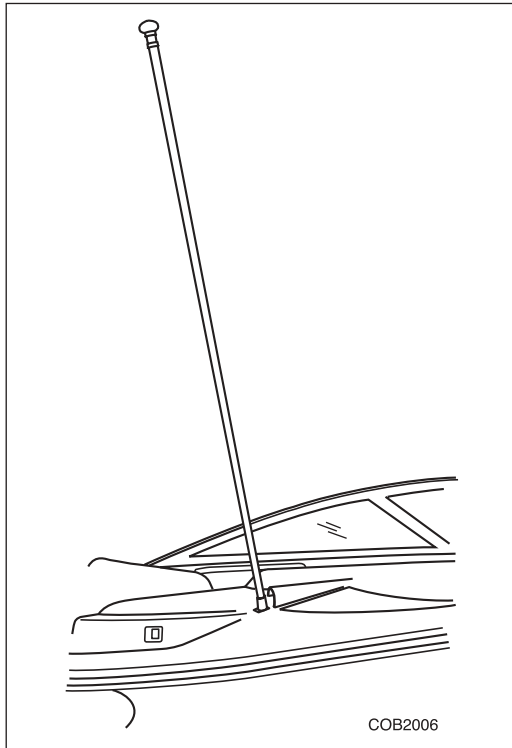

To activate, turn on the navigation light switch. The anchor light will first raise into position, then illuminate. When the light switch is turned off, the light will immediately turn off and after a 1.5 second computer check, the pole will automatically retract into its below-deck storage position. The top of the lens will be flush with the top of the deck ring. If the light does not retract automatically, do not force down, contact your Cobalt Dealer.

To operate the S.O.S. distress signal, turn on the anchor light and allow it to fully extend and illuminate. Wait a minimum of two seconds as the light runs a circuit check. Anytime thereafter, you may toggle the light switch (rapidly turning the light off then immediately back on). The light will start to flash the Morse code S.O.S. and continue flashing S.O.S. until it is toggled again. The light will then illuminate constantly. You may turn the anchor light off in either mode and it will retract automatically.

ANCHOR LIGHT

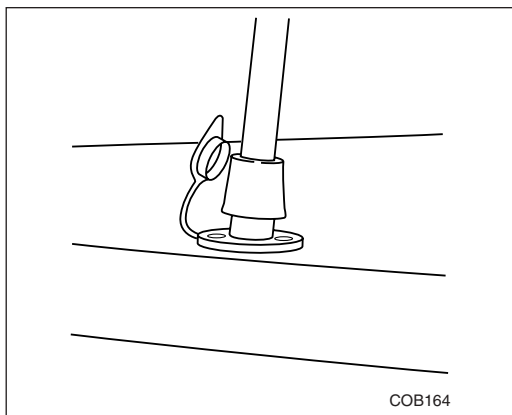

To install anchor light insert pole into socket and turn clockwise until it locks into place.

Cap the anchor light socket when the anchor light is removed.



ROSEWOOD DASH (OPTIONAL) CARE

Your Rosewood veneer dash will maintain its natural beauty and high-gloss sheen when properly maintained.

- For routine cleaning wipe the wood surface with a damp soft cotton cloth. For thorough cleaning wash surface with a mild solution of soap and water, and dry with a soft cotton cloth.
- Wax or rubbing compound can be used occasionally when necessary.
- Apply liquid wax product lightly with your fingertips. Work from the center of the wood surface outward. Rub in a circular motion and stop about 1/4 inch from exterior edges of the wood. Remove wax with a clean soft cloth.
- For difficult-to-clean surfaces 3M Perfect-It III rubbing compound and a 3M “Type T” scrubbing pad can be used. Use rubbing compound carefully following manufacturer’s instructions.
- Do not use cleaners or polishes containing alcohol, ammonia, abrasives, oily emollients or petroleum-based materials.
- Avoid saturating edges of wood laminate with polish or wax. In some instances foam-backed tape used in manufacturing will absorb and retain these substances and result in premature fading and/or discoloration of your Rosewood dash. If cleaners or waxes come in contact with edges of the wood laminate, clean the surface immediately with a mild solution of soap and water.

MOTOR BOX ASSEMBLY

Manual – The motor box raises and lowers manually. Do not allow it to slam shut when closing.

Electric (Optional) – The electric motor box assembly is controlled by a switch on the dash. If you experience a battery failure, the assembly can be opened manually.

COCKPIT DINETTE TABLE - OPTIONAL

Remove the j-shaped table leg from the storage area. Slide socket cover up and insert the leg. Tighten thumbscrews on the leg for desired tightness. Slide the table top onto the leg and tighten the lever.

AIR COMPRESSOR - OPTIONAL

A high volume air pump is conveniently located in the starboard aft walk thru storage compartment to inflate your favorite water toys. Plug into the accessory receptacle on the dash or in the air compressor area.



PERFECT PASS - OPTIONAL

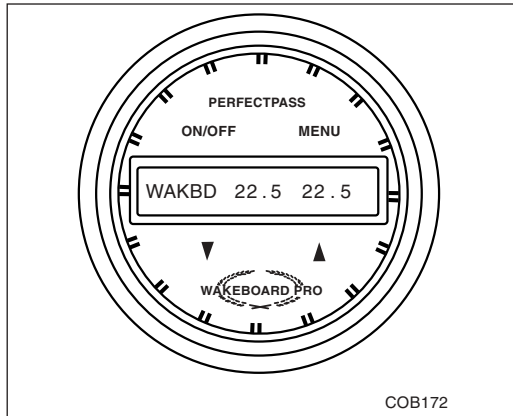

To operate the Perfect Pass speed control system set desired speed on Perfect Pass. Once your boat reaches the set speed Perfect Pass takes over and holds the speed constant. For additional operating information refer to operator's manual.



ELECTRICAL WIRING HARNESS

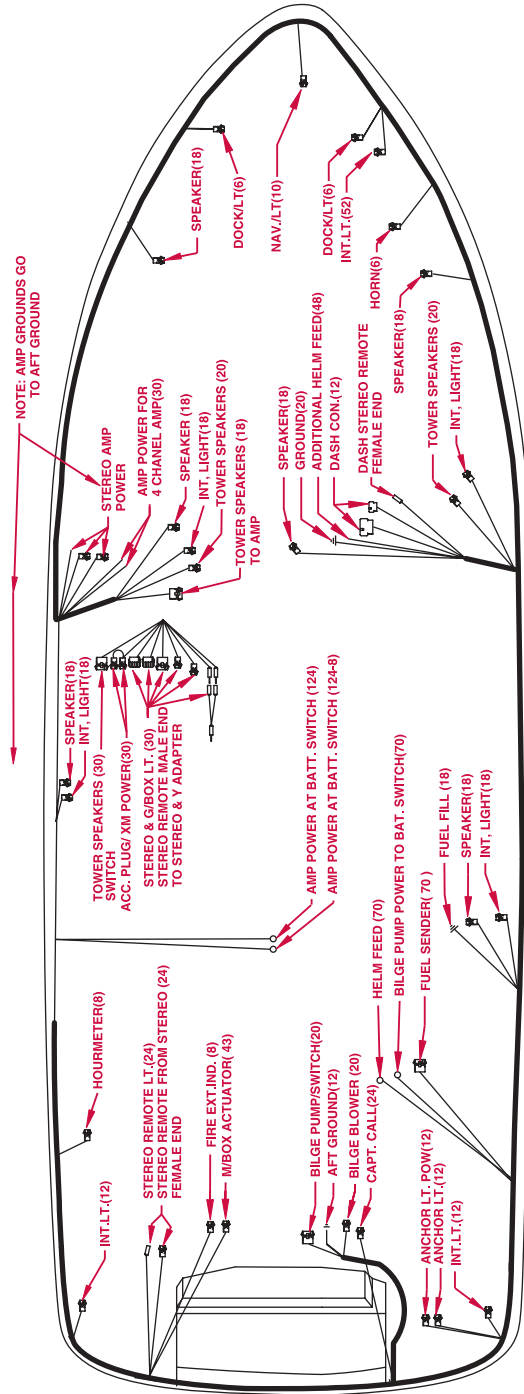

COB2008



FUEL ROUTING

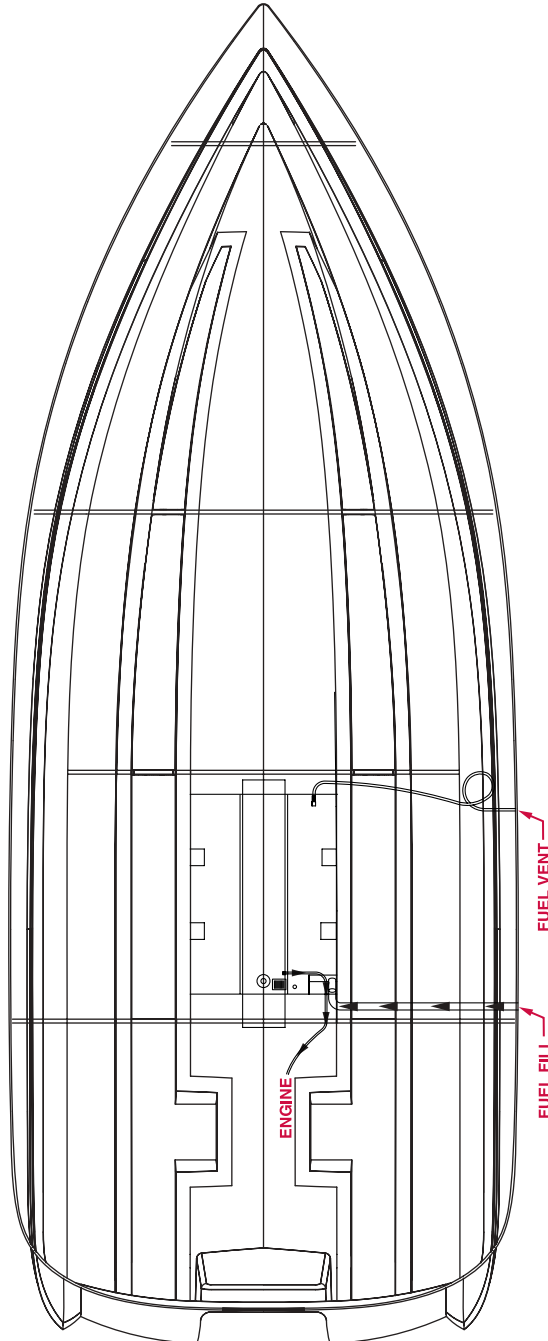

COB2009



PROPELLER APPLICATION CHART

Model	Mfgr.	Engine	Drive	Fuel system	Std. Ratio	Optional Ratio	Php	Propeller Description	Mfgr. Part Number
200	MERC	4.3 L MPI	ALPHA	MPI	1.62	1.81	220		
200	MERC	4.3 L MPI	BRAVO 3	MPI	2.2	2.43	220		
200	MERC	5.0 L MPI	ALPHA	MPI	1.47	1.62	260	19 MAX RH	48-832830A45
200	MERC	5.0 L MPI	BRAVO 1	MPI	1.65	1.65	260		
200	MERC	5.0 L MPI	BRAVO 3	MPI	2.2	2.43	260		
200	MERC	350 MAG MPI	ALPHA	MPI	1.47	1.62	300	19 MAX RH	48-832830A45
200	MERC	350 MAG MPI	BRAVO 1	MPI	1.5	1.65	300		
200	MERC	350 MAG MPI	BRAVO 3	MPI	2	2.2	300		
200	MERC	6.2 MX MPI	BRAVO 1	MPI	1.65	1.65	320		
200	MERC	6.2 MX MPI	BRAVO 3	MPI	2.2	2.43	320		
200	VOLVO	4.3 GXi	SX	TBI	1.79	1.89	225	19 AL RH	3850301
200	VOLVO	4.3 GXi	DP	TBI	2.32	2.32	225		
200	VOLVO	5.0 GXi	SX	TBI	1.6	1.79	270	19 AL RH	3850301
200	VOLVO	5.0 GXi	DP	TBI	1.95	2.32	270		
200	VOLVO	5.7 Gi	SX	TBI	1.51	1.51	280	17 AL RH	3850300
200	VOLVO	5.7 Gi	DP	TBI	1.95	1.95	280		
200	VOLVO	5.7 GXi	SX	TBI	1.51	1.51	320		
200	VOLVO	5.7 GXi	DP	TBI	1.95	1.95	320		



220

MODEL SPECIFIC INFORMATION

COBALT BOATS - OWNER'S MANUAL

LAYOUT AND SPECIFICATIONS

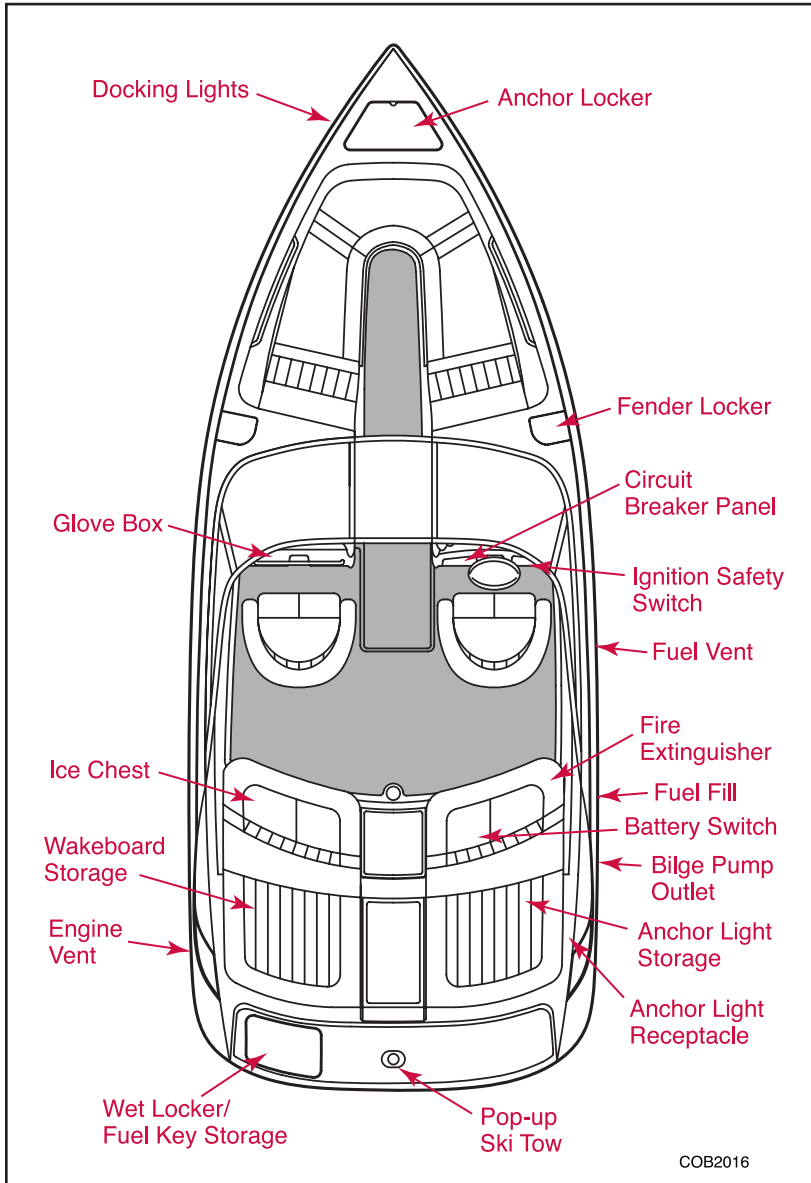

SPECIFICATIONS

StyleBowrider	
Centerline22' 0"	(6.70 m)
Centerline w/ext.		
Swim Platform24' 0"	(7.30 m)
Beam8' 6"	(2.62 m)
Dry Weight4150 lbs.	(1890 kg)
Deadrise20°	
Fuel Capacity50 gal.	(189 l)
Draft (drive up)24"	(61 cm)
Draft (drive down)36"	(92 cm)
Freeboard, forward33"	(84 cm)
Freeboard, aft34"	(86 cm)
Bridge Clearance51"	(1.3 m)
Bridge Clearance		
w/Tower101"	(2.6 m)
Trailer Height6' 10"	(2.1 m)
Trailer Height		
w/Tower10' 5"	(3.2 m)
Capacity, weight1700 lbs.	(771 kg)
Capacity, persons11	

COB2016



CAPTAIN'S CHAIR ADJUSTMENT AND OPERATION

Your captain's chairs have the flip-up position for greater visibility and maneuverability while docking. You can sit on the raised cushion or stand in front of the cushion. Standing while driving your boat should only be done while maneuvering at an idle by an experienced driver.

The chairs are adjustable fore and aft and also rotate.

Rotation - Loosen the "T" handle next to the pedestal under the seat. Raise the lever on the opposite side of the pedestal. Rotate the seat to the desired position and lower the lever and tighten the knob to tighten the seat. Do not allow the seat to swing freely.

Fore and Aft adjustments - A handle under the front lip of the seat when raised allows the seat to move. Make sure the mechanism is properly engaged to prevent seat movement while the boat is underway.

SWIVEL CHAIRS ADJUSTMENT AND OPERATION – OPTIONAL

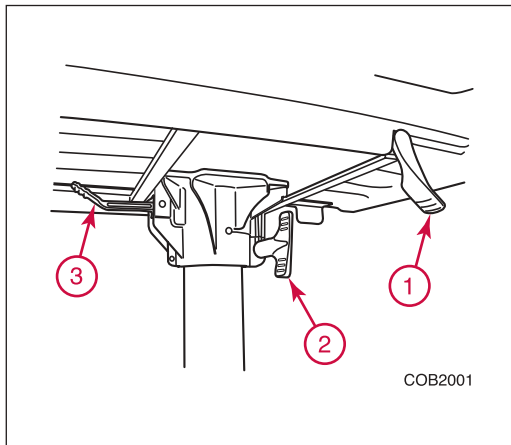

Your optional swivel chairs have the capability to rotate for convenience when moored or docked and for the passenger to spot a skier when skiing.

Both chairs rotate and are adjustable fore and aft.

1. Lift lever to adjust fore and aft.
2. Turn rotation friction handle clockwise to increase friction and counterclockwise to decrease friction. The chair should always be operated with slight friction.
3. Rotation lever for chair - move chair slightly forward, then lift lever to rotate. The lever will rest in its detent when the seat is in its forward direction.



WARNING

DRIVING WHILE STANDING UP IS AN EXTREMELY HAZARDOUS PRACTICE. DO NOT DRIVE WHILE STANDING AT SPEEDS GREATER THAN "IDLE SPEED."



CAUTION

ALL SEATS MUST BE IN A LOCKED/SECURED POSITION WHILE THE BOAT IS UNDERWAY.



INSTRUMENT PANEL

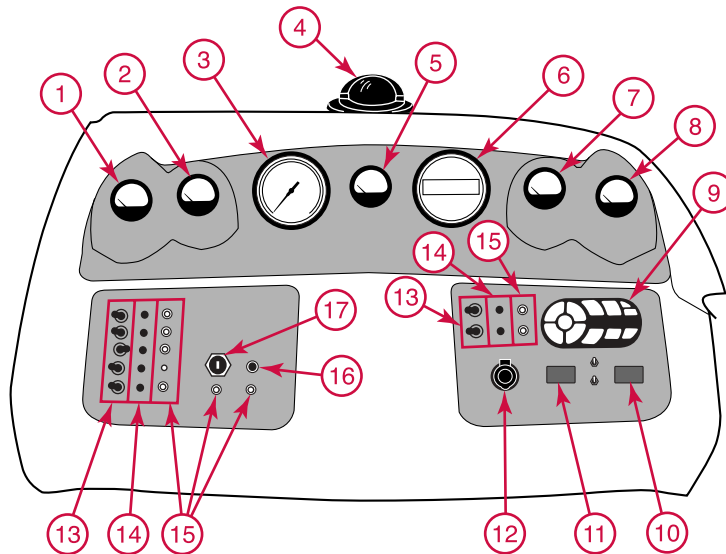

COB2002

1. Temperature Gauge - Temperature may fluctuate slightly while running. Maximum temperature may vary depending on type of engine.
2. Oil Pressure Gauge - Pressure can vary according to type of engine. It is normal for a hot engine to have low pressure at idle, (depending on type of oil, pressure may drop as low as 10 PSI at idle).
Please consult the engine owner's manual supplied with your boat concerning the oil pressure the engine in your boat should attain.
3. Speedometer (Miles Per Hour)
4. Compass - optional.
5. Fuel Gauge - shows approximate amount of fuel remaining in tank.



WARNING

SHOULD WATER TEMPERATURE REACH 180 DEGREES FAHRENHEIT, YOUR ENGINE IS OVERHEATING AND SHOULD BE CHECKED IMMEDIATELY FOR PROBABLE CAUSE.

6. Tachometer - (Revolutions Per Minute) or Optional Perfect Pass.
7. Voltmeter - shows the condition of charge in the battery. It only indicates while the ignition is in the "ON" position. With the engine at idle or not running, it may show as low as 10 to 12 volts. With the engine running at cruising speeds and above, it should show 12 to 14 volts.
8. Trim Gauge - Shows the position of the drive unit in reference to the bottom of the boat.
9. Stereo Remote Control (optional)
10. Air/Water Temperature Gauge - Moving the toggle switch below the gauge allows you to go between air and water temperature readings. The gauge will display AIR and WATER to indicate which temperature source is in use.
11. Depth Sounder - Your Cobalt is equipped with a depth sounder. To see your options - shallow, deep, keel depth and units - toggle switch to down position. To set each option to desired reading toggle switch to up position. Consult your Cobalt Dealer for further information.
12. 12V Accessory Receptacle
13. Two Position Switch - Controls equipment as labeled.
 - NAV/ANC - Three Position Exterior Light Switch NAV. position - navigation (running) lights, bow light and stern light. Center position - off. ANC. position - stern light only. This switch will also activate the optional telescoping anchor light, if equipped.
14. On/Off Indicator Lights



- 15. Circuit Breakers - Push to reset if necessary. If the button continues to pop out, consult your Authorized Cobalt Dealer.
- 16. Horn Button - The horn, itself, is located under the deck.
- 17. Ignition Key Switch



WARNING

NEVER OPERATE YOUR BOAT AT NIGHT WITHOUT ALL OF THE REQUIRED LIGHTS OPERATING. THIS INCLUDES BOW LIGHT AND REMOVABLE STERN LIGHT. MAKE SURE LIGHTS ARE NOT BLOCKED BY CANVAS OR OTHER OBSTACLES.

EXTENDED SWIM PLATFORM / BOARDING LADDER

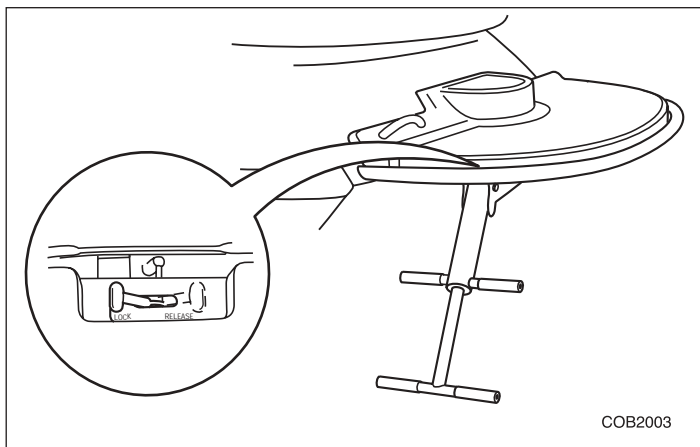

The swim platform was designed for use by people – not for the storage of personal equipment. Maximum platform weight capacity is 800 pounds. If the swim platform is removed, the boat will not pass Coast Guard inspection, and the boat cannot be boarded until a boarding ladder is installed. The swim platform may be removed for off-season storage only.



WARNING

EXTENDED SWIM PLATFORM MUST BE ATTACHED WHILE BOAT IS IN USE TO AVOID POSSIBLE INJURY OR DROWNING. SWIM LADDER IS ATTACHED TO THE PLATFORM. REMOVABLE FEATURE IS FOR BOAT STORAGE ONLY.



WARNING

DO NOT OCCUPY EXTENDED SWIM PLATFORM WHILE ENGINE IS RUNNING OR ENGAGED. PROPELLER CONTACT MAY CAUSE SEVERE INJURY OR FATALITY. ALL GASOLINE POWERED ENGINES PRODUCE CARBON MONOXIDE (CO). CO IS COLORLESS, ODORLESS, AND DANGEROUS. DIRECT AND PROLONGED EXPOSURE TO CO WILL CAUSE BRAIN DAMAGE OR DEATH.

LADDER MUST ONLY BE USED WHILE THE ENGINE IS OFF. (See warning label section.) Be sure the ladder is raised and secured prior to starting engine. Exercise caution while using the ladder.

Use the release lever to release the ladder and telescope to full length. Lift ladder to retract and stow. Place release lever in the LOCK position. Use caution when stowing the ladder to prevent pinching fingers.



WARNING

DO NOT USE BOARDING LADDER WHILE ENGINE IS RUNNING.



CAUTION

THE STERN DRIVE UNIT HAS MANY SHARP EDGES, ESPECIALLY THE PROPELLER. EXERCISE CAUTION WHEN NEAR THE STERN DRIVE UNIT. ALWAYS MAKE SURE THE BOARDING LADDER IS PROPERLY STOWED AND THERE IS NO ONE IN THE AREA BEHIND THE BOAT BEFORE STARTING THE ENGINE AND ENGAGING THE SHIFT MECHANISM.

WINDSHIELD HOOK

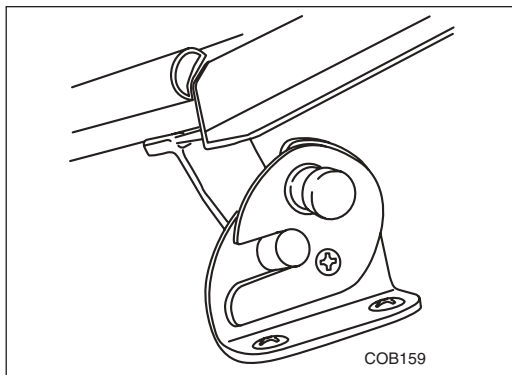

To open the windshield make sure the vertical slots in the mechanism are aligned. Swing the windshield open until the windshield post falls into the vertical slots and the mechanism locks.

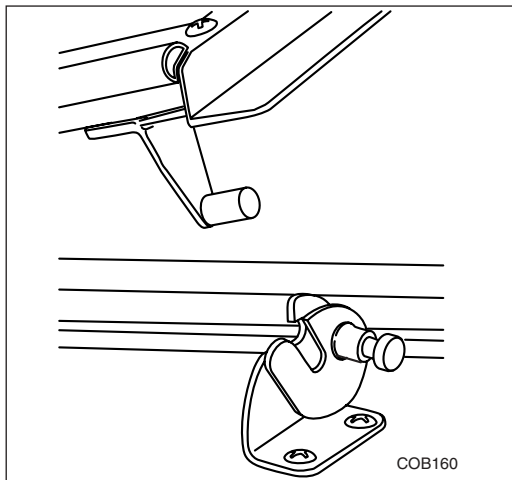

To close the windshield release the locking mechanism by pulling the forward-facing button. Swing the windshield into place.



AFT WALK-THRU FILLER CUSHIONS – OPTIONAL

The starboard rear walk-thru area can be converted into a large sundeck pad over the motor box by installing aft filler cushions. Snap the cushions in place.

BOW CUSHION INSERT – OPTIONAL

The bow area can be converted into a sundeck by inserting the bow cushion insert.

POP-UP SKI TOW

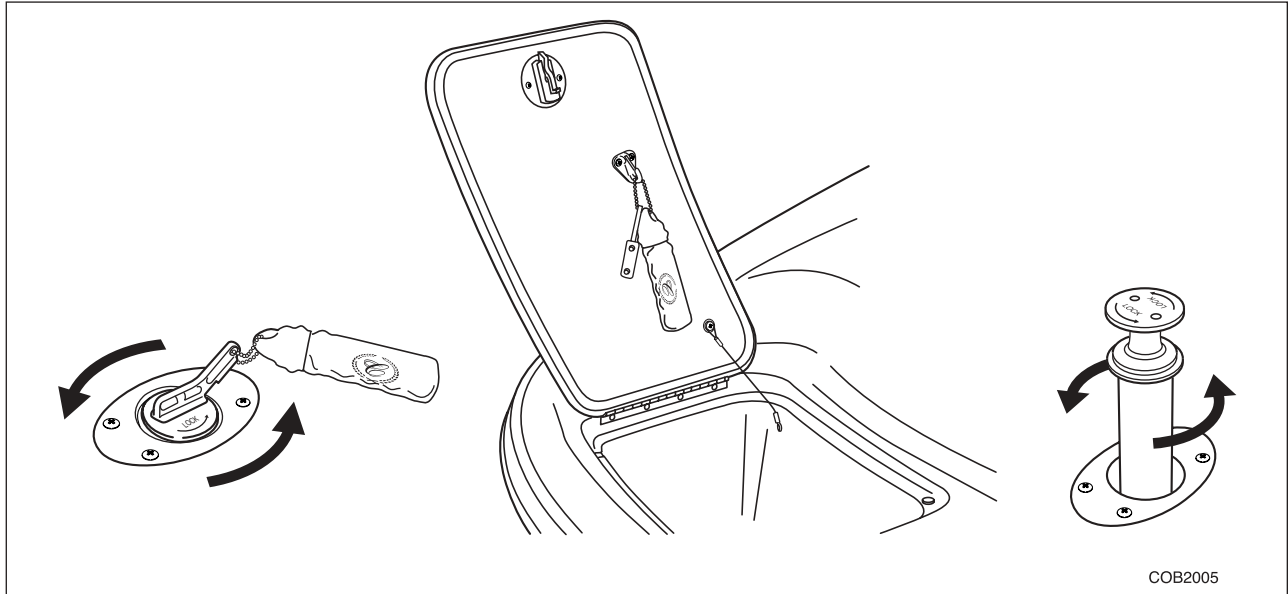

The stainless steel pop-up ski tow is designed for concealment as well as function.

- Using the fuel cap key, turn the ski tow counterclockwise to pop-up.
- Lift up and continue to turn counterclockwise to lock into position.
- To stow, turn clockwise to lower and using the key, press down and continue to turn clockwise until it is in its locked position.

Use the key storage clasp inside the wet locker for convenient key storage.



DANGER

SKI TOWER IS DESIGNED FOR A SINGLE SKIER ONLY.



TELESCOPING ANCHOR LIGHT – OPTIONAL

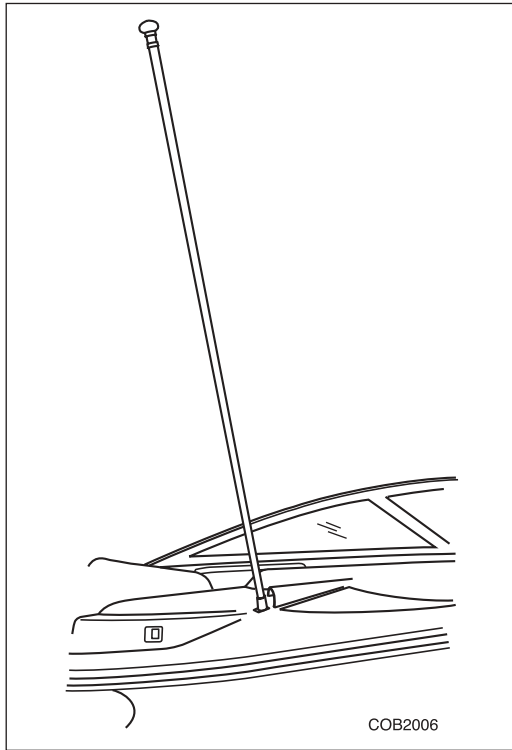

To activate, turn on the navigation light switch. The anchor light will first raise into position, then illuminate. When the light switch is turned off, the light will immediately turn off and after a 1.5 second computer check, the pole will automatically retract into its below-deck storage position. The top of the lens will be flush with the top of the deck ring. If the light does not retract automatically, do not force down, contact your Cobalt Dealer.

To operate the S.O.S. distress signal, turn on the anchor light and allow it to fully extend and illuminate. Wait a minimum of two seconds as the light runs a circuit check. Anytime thereafter, you may toggle the light switch (rapidly turning the light off then immediately back on). The light will start to flash the Morse code S.O.S. and continue flashing S.O.S. until it is toggled again. The light will then illuminate constantly. You may turn the anchor light off in either mode and it will retract automatically.

ANCHOR LIGHT

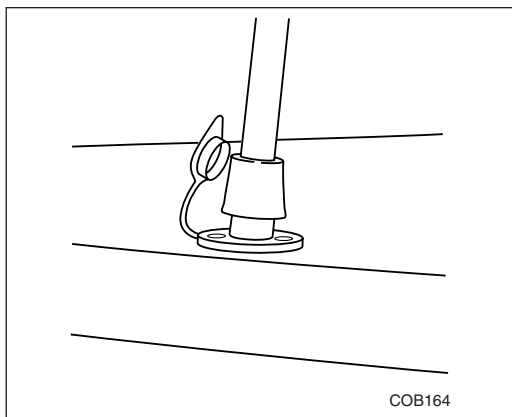

To install anchor light insert pole into socket and turn clockwise until it locks into place.

Cap the anchor light socket when the anchor light is removed.



ROSEWOOD DASH (OPTIONAL) CARE

Your Rosewood veneer dash will maintain its natural beauty and high-gloss sheen when properly maintained.

- For routine cleaning wipe the wood surface with a damp soft cotton cloth. For thorough cleaning wash surface with a mild solution of soap and water, and dry with a soft cotton cloth.
- Wax or rubbing compound can be used occasionally when necessary.
- Apply liquid wax product lightly with your fingertips. Work from the center of the wood surface outward. Rub in a circular motion and stop about 1/4 inch from exterior edges of the wood. Remove wax with a clean soft cloth.
- For difficult-to-clean surfaces 3M Perfect-It III rubbing compound and a 3M “Type T” scrubbing pad can be used. Use rubbing compound carefully following manufacturer’s instructions.
- Do not use cleaners or polishes containing alcohol, ammonia, abrasives, oily emollients or petroleum-based materials.
- Avoid saturating edges of wood laminate with polish or wax. In some instances foam-backed tape used in manufacturing will absorb and retain these substances and result in premature fading and/or discoloration of your Rosewood dash. If cleaners or waxes come in contact with edges of the wood laminate, clean the surface immediately with a mild solution of soap and water.

MOTOR BOX ASSEMBLY

Manual – The motor box raises and lowers manually. Do not allow it to slam shut when closing.

Electric (Optional) – The electric motor box assembly is controlled by a switch on the dash. If you experience a battery failure, the assembly can be opened manually.

FENDER LOCKERS

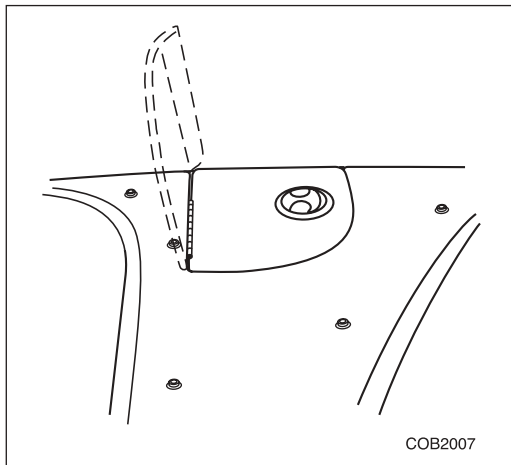

Use the fender lockers to stow fenders when they are not in use.



COCKPIT DINETTE TABLE - OPTIONAL

Remove the j-shaped table leg from the storage area. Slide socket cover up and insert the leg. Tighten thumbscrews on the leg for desired tightness. Slide the table top onto the leg and tighten the lever.

AIR COMPRESSOR - OPTIONAL

A high volume air pump is conveniently located in the starboard aft walk thru storage compartment to inflate your favorite water toys. Plug into the accessory receptacle on the dash or in the air compressor area.

PERFECT PASS - OPTIONAL

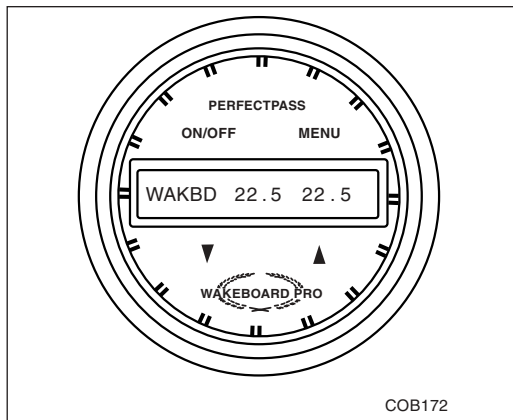

To operate the Perfect Pass speed control system set desired speed on Perfect Pass. Once your boat reaches the set speed Perfect Pass takes over and holds the speed constant. For additional operating information refer to operator's manual.



ELECTRICAL WIRING HARNESS

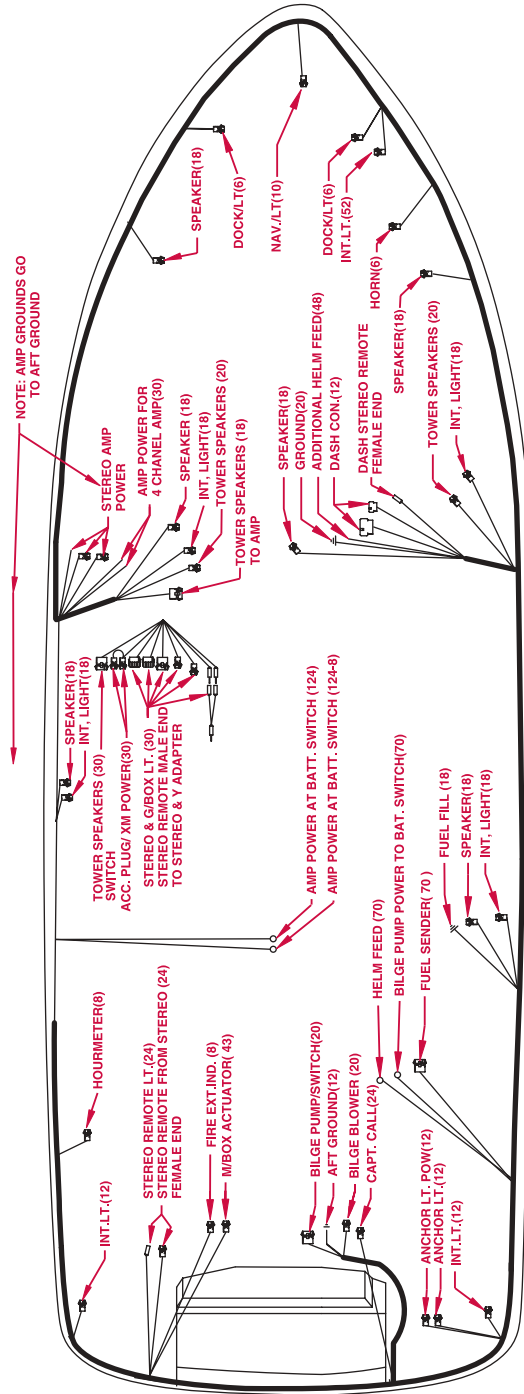

COB2008



FUEL ROUTING

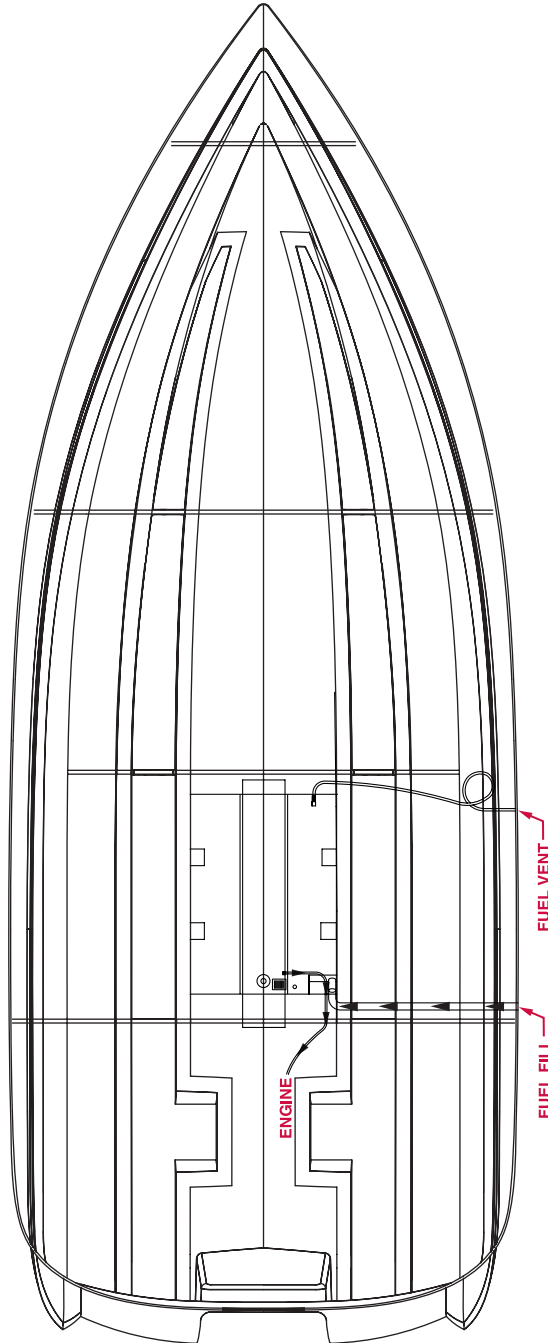

COB2009



PROPELLER APPLICATION CHART

Model	Mfgr.	Engine	Drive	Fuel system	Std. Ratio	Optional Ratio	Php	Propeller Description	Mfgr. Part Number
220	MERC	5.0 L MPI	ALPHA	MPI	1.47	1.62	260	19 MAX RH	48-832830A45
220	MERC	5.0 L MPI	BRAVO 1	MPI	1.65	1.65	260		
220	MERC	5.0 L MPI	BRAVO 3	MPI	2.2	2.43	260		
220	MERC	350 MAG MPI	ALPHA	MPI	1.47	1.62	300	19 MAX RH	48-832830A45
220	MERC	350 MAG MPI	BRAVO 1	MPI	1.5	1.65	300		
220	MERC	350 MAG MPI	BRAVO 3	MPI	2	2.2	300		
220	MERC	6.2 MX MPI	BRAVO 1	MPI	1.65	1.65	320		
220	MERC	6.2 MX MPI	BRAVO 3	MPI	2.2	2.43	320		
220	MERC	496 MAG MPI	BRAVO 1	MPI	1.5	1.65	375		
220	MERC	496 MAG MPI	BRAVO 3	MPI	1.81	2.2	375		
220	MERC	496 MAG HO	BRAVO 1	MPI	1.5	1.65	425		
220	MERC	496 MAG HO	BRAVO 3	MPI	1.81	2.2	425		
220	VOLVO	5.0 GXi	SX	TBI	1.6	1.79	270	19 AL RH	3850301
220	VOLVO	5.0 GXi	DP	TBI	1.95	2.32	270		
220	VOLVO	5.7 Gi	SX	TBI	1.51	1.51	280		
220	VOLVO	5.7 Gi	DP	TBI	1.95	1.95	280		
220	VOLVO	5.7 GXi	SX	TBI	1.51	1.51	320		
220	VOLVO	5.7 GXi	DP	TBI	1.95	1.95	320		
220	VOLVO	8.1 Gi	DP	MFI	1.78	1.78	375		
220	VOLVO	8.1 GXi	DP	MFI	1.78	1.78	420		



MODEL SPECIFIC INFORMATION

COBALT BOATS - OWNER'S MANUAL

226

LAYOUT AND SPECIFICATIONS

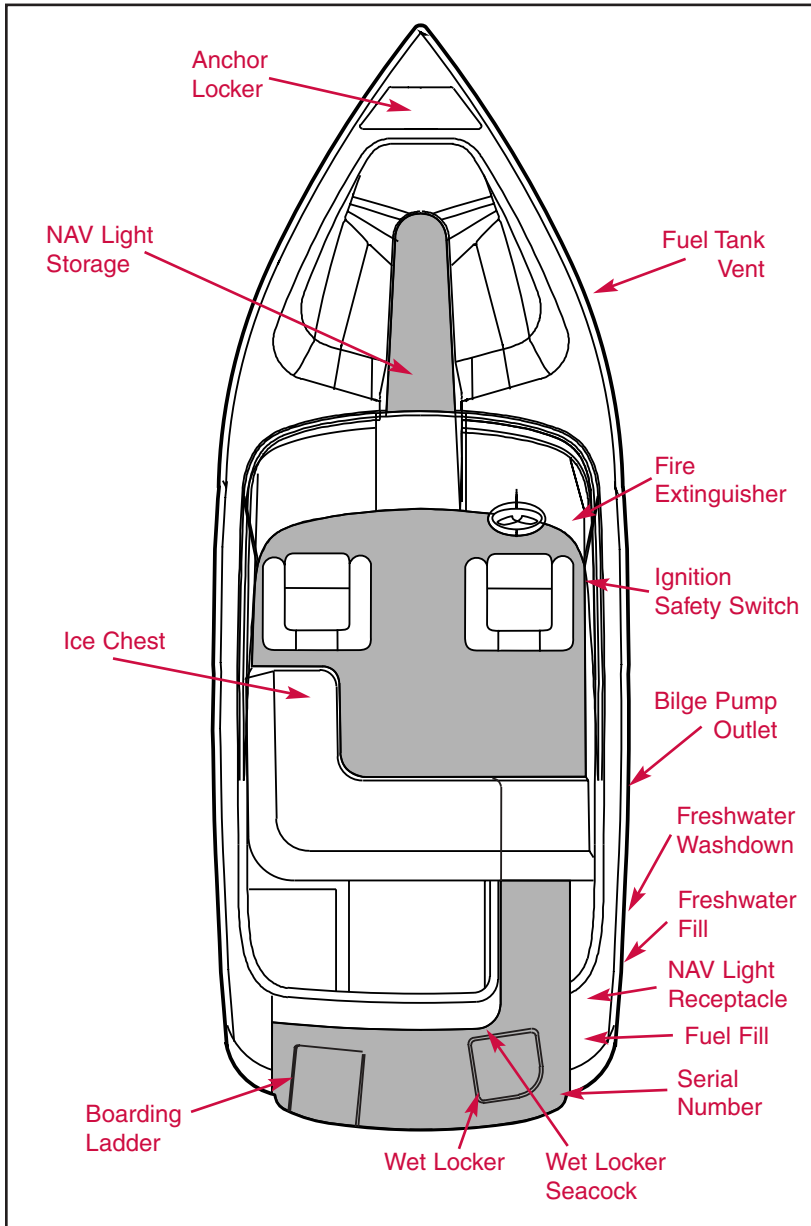

SPECIFICATIONS

Centerline	22'8"	6.91 m
Beam	8' 6"	2.59 m
Dry Weight	3800 lbs.	1723 kg
Deadrise	20 deg.	20 deg.
Fuel Capacity	50 gal.	189 L
Draft(drive up)	20"	50 cm
Freeboard(fwd)	33"	84 cm
Freeboard(aft)	20"	51 cm
Transom Height	42"	107 cm
Bridge Clearance (w/o nav light)	54"	137 cm
Capacity	11 Persons	
Capacity by Weight	1700 lbs	771 kg



CAPTAIN'S CHAIR ADJUSTMENT AND OPERATION

Your captain's chairs have the flip-up position for greater visibility and maneuverability while docking. You can sit on the raised cushion or stand in front of the cushion. Standing while driving your boat should only be done while maneuvering at an idle by an experienced driver.

The chairs are adjustable fore and aft and also rotate.

Rotation - Loosen the "T" handle next to the pedestal under the seat. Raise the lever on the opposite side of the pedestal. Rotate the seat to the desired position and lower the lever and tighten the knob to tighten the seat. Do not allow the seat to swing freely.

Fore and Aft adjustments - A handle under the front lip of the seat when raised allows the seat to move. Make sure the mechanism is properly engaged to prevent seat movement while the boat is underway.



WARNING

DRIVING WHILE STANDING UP IS AN EXTREMELY HAZARDOUS PRACTICE. DO NOT DRIVE WHILE STANDING AT SPEEDS GREATER THAN "IDLE SPEED."



CAUTION

ALL SEATS MUST BE IN A LOCKED/SECURED POSITION WHILE THE BOAT IS UNDERWAY.

INSTRUMENT PANEL

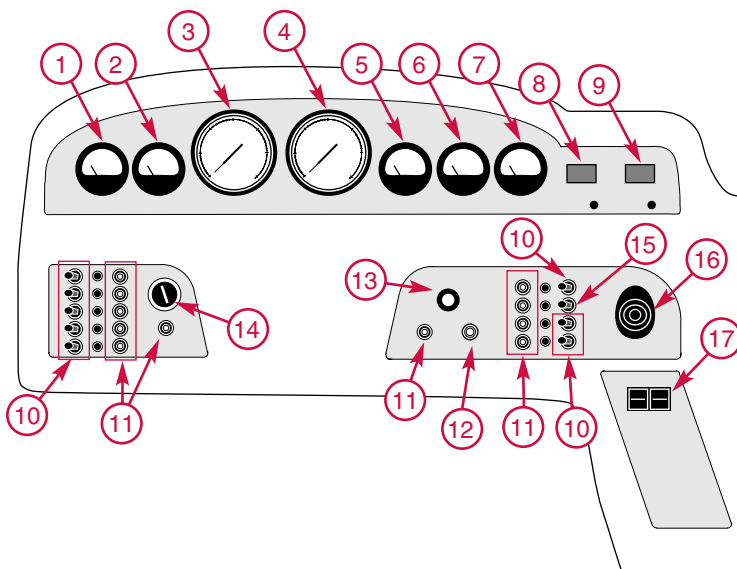

1. Fuel Gauge - shows approximate amount of fuel remaining in tank.
2. Voltmeter - shows the condition of charge in the battery. It only indicates while the ignition is in the "ON" position. With the engine at idle or not running, it may show as low as 10 to 12 volts. With the engine running at cruising speeds and above, it should show 12 to 14 volts.
3. Speedometer (Miles Per Hour)
4. Tachometer - (Revolutions Per Minute)
5. Temperature Gauge - Temperature may fluctuate slightly while running. Maximum temperature may vary depending on type of engine.



WARNING

SHOULD WATER TEMPERATURE REACH 180 DEGREES FAHRENHEIT, YOUR ENGINE IS OVERHEATING AND SHOULD BE CHECKED IMMEDIATELY FOR PROBABLE CAUSE.



6. Oil Pressure Gauge - Pressure can vary according to type of engine. It is normal for a hot engine to have low pressure at idle, (depending on type of oil, pressure may drop as low as 10 PSI at idle).
Please consult the engine owner's manual supplied with your boat concerning the oil pressure the engine in your boat should attain.
7. Trim Gauge - Shows the position of the drive unit in reference to the bottom of the boat.
8. Air/Water Temperature Gauge - Moving the toggle switch below the gauge allows you to go between air and water temperature readings. The gauge will display AIR and WATER to indicate which temperature source is in use.
9. Depth Sounder - Your Cobalt is equipped with a depth sounder. To see your options - shallow, deep, keel depth and units - toggle switch to down position. To set each option to desired reading toggle switch to up position. Consult your Cobalt Dealer for further information.
10. Two Position Switch - Controls equipment as labeled.
11. Circuit Breakers - Push to reset if necessary. If the button continues to pop out, consult your Authorized Cobalt Dealer.
12. Horn Button - The horn, itself, is located under the deck.
13. Dimmer Switch - Your Cobalt is equipped with a dimmer switch which controls the intensity of the dash lights including the compass light.
14. Ignition Key Switch
15. Three Position Exterior Light Switch NAV. position - navigation (running) lights, bow light and stern light. Center position - off. ANC. position - stern light only.



WARNING

NEVER OPERATE YOUR BOAT AT NIGHT WITHOUT ALL OF THE REQUIRED LIGHTS OPERATING. THIS INCLUDES BOW LIGHT AND REMOVABLE STERN LIGHT. MAKE SURE LIGHTS ARE NOT BLOCKED BY CANVAS OR OTHER OBSTACLES.

16. Stereo Remote Control
17. Trim Tabs (optional)

TELESCOPING BOARDING LADDER

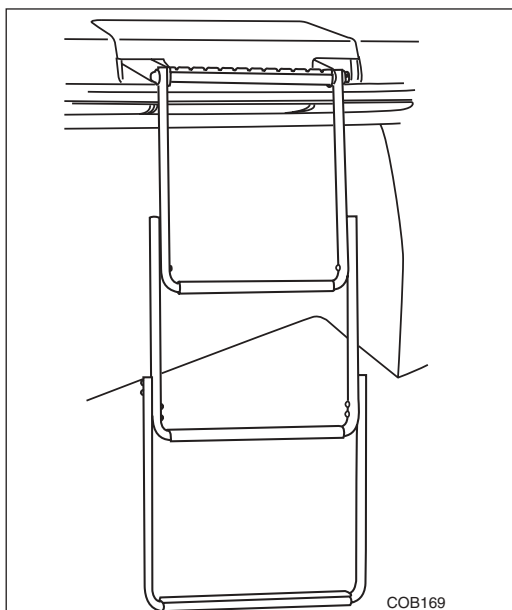

THIS LADDER MUST ONLY BE USED WHILE ENGINE IS OFF. (See warning label section). Be sure ladder is raised and secured prior to starting engine. Caution should be used while using this ladder.

Telescoping ladder is covered by ladder lid. Lift ladder lid to access ladder. Lift up on front of ladder to place overboard and telescope to full length. Use caution to prevent pinching fingers when stowing ladder.



WARNING

DO NOT USE BOARDING LADDER WHILE ENGINE IS RUNNING.



CAUTION

THE STERN DRIVE UNIT HAS MANY SHARP EDGES, ESPECIALLY THE PROPELLER. EXERCISE CAUTION WHEN NEAR THE STERN DRIVE UNIT. ALWAYS MAKE SURE THE BOARDING LADDER IS PROPERLY STOWED AND THERE IS NO ONE IN THE AREA BEHIND THE BOAT BEFORE STARTING THE ENGINE AND ENGAGING THE SHIFT MECHANISM.

EXTENDED SWIM PLATFORM – OPTIONAL

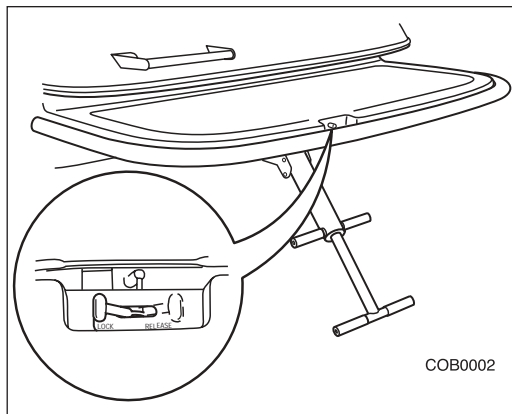

The swim platform was designed for use by people – not for the storage of personal equipment. Maximum platform weight capacity is 800 pounds. If the swim platform is removed, the boat will not pass Coast Guard inspection, and the boat cannot be boarded until a boarding ladder is installed. The swim platform may be removed for off-season storage only.



WARNING

EXTENDED SWIM PLATFORM MUST BE ATTACHED WHILE BOAT IS IN USE TO AVOID POSSIBLE INJURY OR DROWNING. SWIM LADDER IS ATTACHED TO THE PLATFORM. REMOVABLE FEATURE IS FOR BOAT STORAGE ONLY.



WARNING

DO NOT OCCUPY EXTENDED SWIM PLATFORM WHILE ENGINE IS RUNNING OR ENGAGED. PROPELLER CONTACT MAY CAUSE SEVERE INJURY OR FATALITY. ALL GASOLINE POWERED ENGINES PRODUCE CARBON MONOXIDE (CO). CO IS COLORLESS, ODORLESS, AND DANGEROUS. DIRECT AND PROLONGED EXPOSURE TO CO WILL CAUSE BRAIN DAMAGE OR DEATH.

LADDER MUST ONLY BE USED WHILE THE ENGINE IS OFF. (See warning label section.) Be sure the ladder is raised and secured prior to starting engine. Exercise caution while using the ladder.

Use the release lever to release the ladder and telescope to full length. Lift ladder to retract and stow. Place release lever in the LOCK position. Use caution when stowing the ladder to prevent pinching fingers.



WARNING

DO NOT USE BOARDING LADDER WHILE ENGINE IS RUNNING.



CAUTION

THE STERN DRIVE UNIT HAS MANY SHARP EDGES, ESPECIALLY THE PROPELLER. EXERCISE CAUTION WHEN NEAR THE STERN DRIVE UNIT. ALWAYS MAKE SURE THE BOARDING LADDER IS PROPERLY STOWED AND THERE IS NO ONE IN THE AREA BEHIND THE BOAT BEFORE STARTING THE ENGINE AND ENGAGING THE SHIFT MECHANISM.

WINDSHIELD HOOK

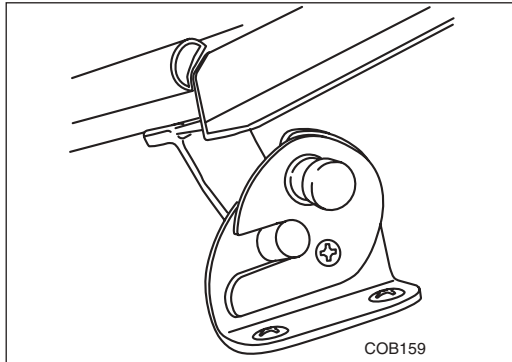

To open the windshield make sure the vertical slots in the mechanism are aligned. Swing the windshield open until the windshield post falls into the vertical slots and the mechanism locks.

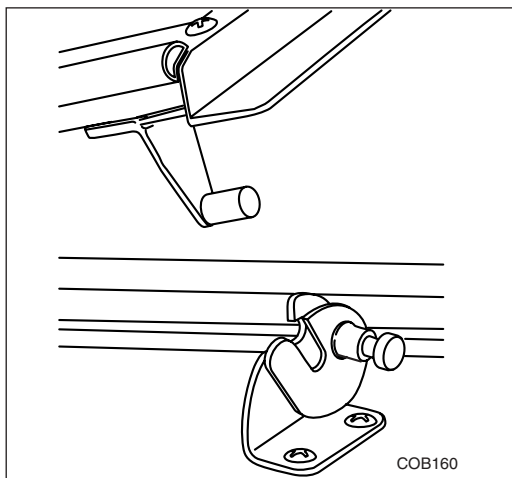

To close the windshield release the locking mechanism by pulling the forward-facing button. Swing the windshield into place.

AFT WALK-THRU FILLER CUSHIONS – OPTIONAL

The starboard rear walk-thru area can be converted into a large sundeck pad over the motor box by installing aft filler cushions. Snap the bottom cushion in place. Secure the barrel bolts on the underside of the extended pad before using.

WATER SYSTEM

If your Cobalt is equipped with an optional transom shower, standard or optional galley, the system allows for a 10-gallon capacity water system. A 12VDC water pump operates the system. It is necessary for the ship's batteries to be turned ON for the water system to operate. Consult your Cobalt Dealer for winterization requirements.

To clean the water tank, the manufacturer recommends adding 1/4 cup of baking soda into the tank and allowing the tank to stand for one day, then flushing the tank twice. If this is not sufficient to clean the tank, replace the baking soda with 2 tablespoons of bleach and repeat the procedure.



SKI TOWER - OPTIONAL

The Stainless Steel Ski Tower is designed to rotate forward for storing where overhead height is an issue:

- Remove 5/16" allen head screws from both aft deck mounts. 5/16" allen head driver is provided in your boat bag.
- Loosen the forward two 5/16" allen head screws.
- Attach provided foam protectors to upper, forward cross bar of Tower.
- Carefully rotate Ski Tower forward until it rests on deck area just forward of windshield.
- Tighten forward two 5/16" Allen screws.



DANGER

SKI TOWER IS DESIGNED FOR A SINGLE SKIER ONLY.

TELESCOPING ANCHOR LIGHT – OPTIONAL

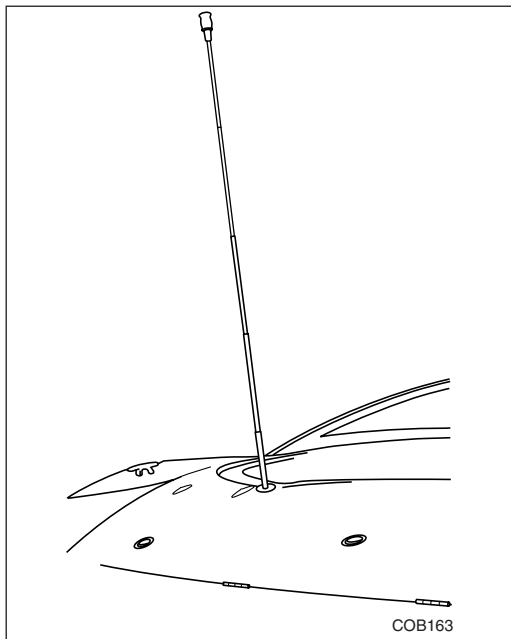

To activate, turn on the navigation light switch. The anchor light will first raise into position, then illuminate. When the light switch is turned off, the light will immediately turn off and after a 1.5 second computer check, the pole will automatically retract into its below-deck storage position. The top of the lens will be flush with the top of the deck ring. If the light does not retract automatically, do not force down, contact your Cobalt Dealer.

ANCHOR LIGHT

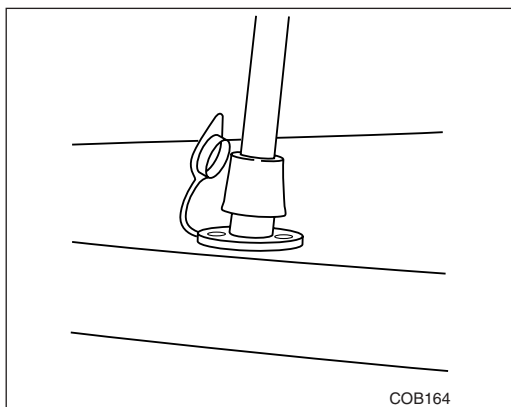

To install anchor light insert pole into socket and turn clockwise until it locks into place.



ROSEWOOD DASH (OPTIONAL) CARE

Your Rosewood veneer dash will maintain its natural beauty and high-gloss sheen when properly maintained.

- For routine cleaning wipe the wood surface with a damp soft cotton cloth. For thorough cleaning wash surface with a mild solution of soap and water, and dry with a soft cotton cloth.
- Wax or rubbing compound can be used occasionally when necessary.
- Apply liquid wax product lightly with your fingertips. Work from the center of the wood surface outward. Rub in a circular motion and stop about 1/4 inch from exterior edges of the wood. Remove wax with a clean soft cloth.
- For difficult-to-clean surfaces 3M Perfect-It III rubbing compound and a 3M “Type T” scrubbing pad can be used. Use rubbing compound carefully following manufacturer’s instructions.
- Do not use cleaners or polishes containing alcohol, ammonia, abrasives, oily emollients or petroleum-based materials.
- Avoid saturating edges of wood laminate with polish or wax. In some instances foam-backed tape used in manufacturing will absorb and retain these substances and result in premature fading and/or discoloration of your Rosewood dash. If cleaners or waxes come in contact with edges of the wood laminate, clean the surface immediately with a mild solution of soap and water.

MOTOR BOX ASSEMBLY

Manual – The motor box raises and lowers manually. Do not allow it to slam shut when closing.

Electric (Optional) – The electric motor box assembly is controlled by a switch on the dash. If you experience a battery failure, the assembly can be opened manually.

COCKPIT DINETTE TABLE - OPTIONAL

Remove the j-shaped table leg from the storage area. Slide socket cover up and insert the leg. Tighten thumbscrews on the leg for desired tightness. Slide the table top onto the leg and tighten with knob.

COCKPIT HEATER - OPTIONAL

To winterize, remove the two 5/8 inch cockpit heater hoses from the engine. Pump antifreeze into one hose until entire heater system is filled..

AIR COMPRESSOR - OPTIONAL

A high volume air pump is conveniently located in the starboard aft walk thru storage compartment to inflate your favorite water toys. Plug into the accessory receptacle on the dash or in the air compressor area.



PERFECT PASS - OPTIONAL

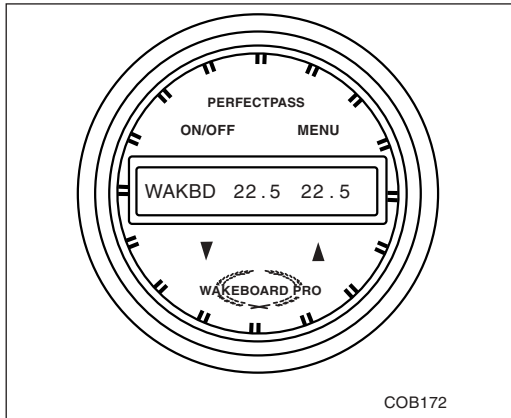

To operate the Perfect Pass speed control system set desired speed on Perfect Pass. Once your boat reaches the set speed Perfect Pass takes over and holds the speed constant. For additional operating information refer to operator's manual.



ELECTRICAL WIRING HARNESS

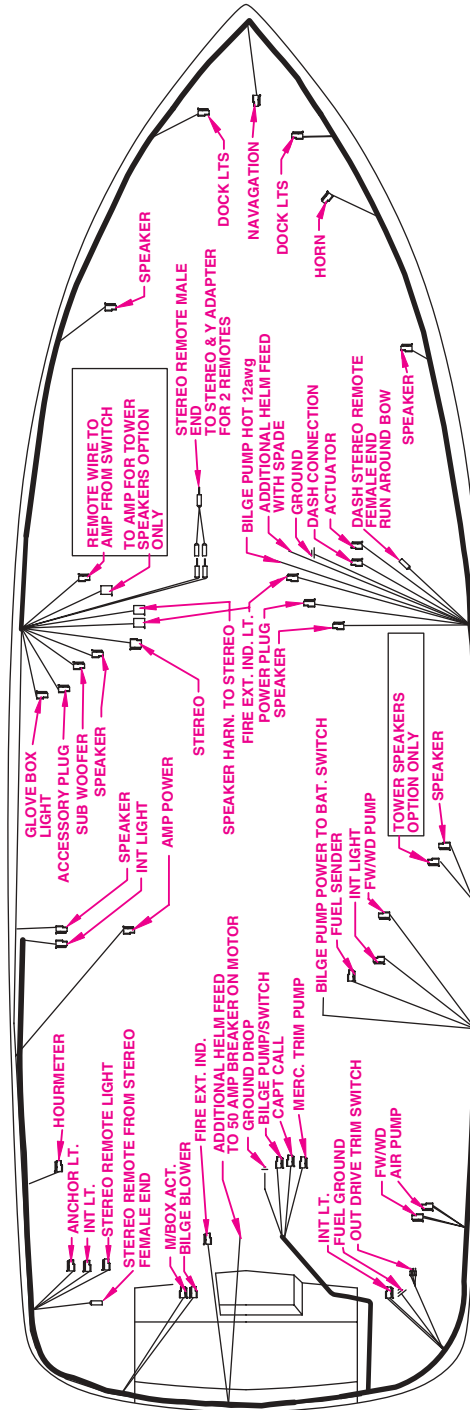

COB180



FUEL ROUTING

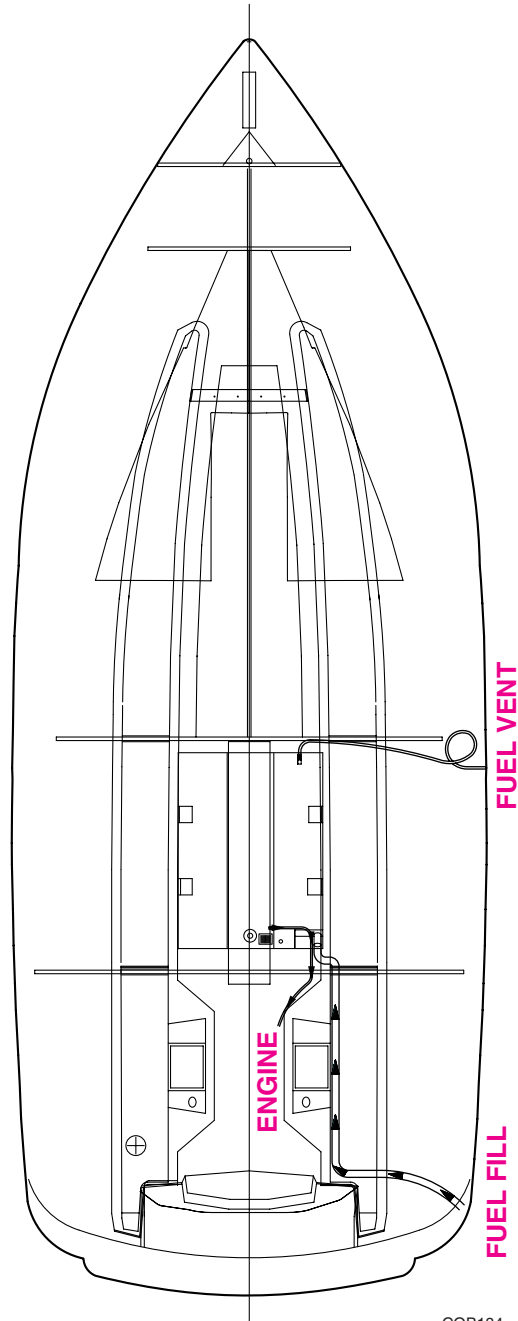

COB184



FRESH WATER PLUMBING

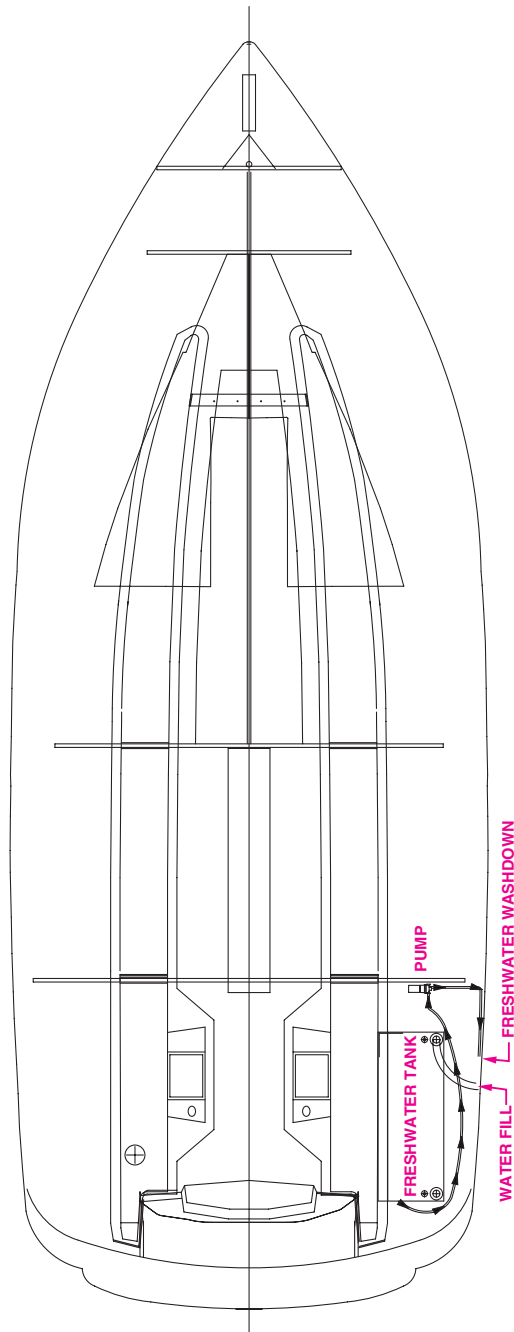

COB185



PROPELLER APPLICATION CHART

Model	Mfgr.	Engine	Drive	Fuel system	Std. Ratio	Optional Ratio	Php	Propeller Description	Mfgr. Part Number
226	MERC	4.3 L	ALPHA	2 BBL	1.62	1.81	190		
226	MERC	4.3 L	BRAVO 3	2 BBL	2.43	2.43	190		
226	MERC	4.3 L MPI	ALPHA	MPI	1.62	1.81	220		
226	MERC	4.3 L MPI	BRAVO 3	MPI	2.2	2.43	220		
226	MERC	5.0 L	ALPHA	2 BBL	1.62	1.81	220		
226	MERC	5.0 L	BRAVO 1	2 BBL	1.65	1.65	220		
226	MERC	5.0 L	BRAVO 3	2 BBL	2.2	2.43	220		
226	MERC	5.7 L	ALPHA	2 BBL	1.47	1.62	250	19 MAX RH	48-832830A45
226	MERC	5.7 L	BRAVO 1	2 BBL	1.65	1.65	250		
226	MERC	5.7 L	BRAVO 3	2 BBL	2.2	2.43	250	28'S B-3	48-823669A60/70A60
226	MERC	5.0 L MPI	ALPHA	MPI	1.47	1.62	260		
226	MERC	5.0 L MPI	BRAVO 1	MPI	1.65	1.65	260		
226	MERC	5.0 L MPI	BRAVO 3	MPI	2.2	2.43	260	26'S B-3	48-823667A60/68A60
226	MERC	350 MAG MPI	ALPHA	MPI	1.47	1.62	300	21 MAX RH	48-832832A45
226	MERC	350 MAG MPI	BRAVO 1	MPI	1.5	1.65	300	19 MIR RH	48-13700A46
226	MERC	350 MAG MPI	BRAVO 3	MPI	2	2.2	300	26'S B-3	48-823667A60/68A60
226	MERC	350 MAG MPI-HZN	BRAVO 3	MPI			300	26'S B-3	48-823667A60/68A60
226	MERC	6.2 MX MPI	BRAVO 1	MPI	1.65	1.65	320	19 MIR RH	48-13700A46
226	MERC	6.2 MX MPI	BRAVO 3	MPI	2.2	2.43	320	28'S B-3	48-823669A60/70A60
226	MERC	496 MAG MPI	BRAVO 1	MPI	1.5	1.65	375	23 MIR RH	48-13704A46
226	MERC	496 MAG MPI	BRAVO 3	MPI	1.81	2.2	375	26'S B-3	48-823667A60/68A60
226	MERC	496 MAG HO	BRAVO 1	MPI	1.5	1.65	425	23 MIR RH	48-13704A46
226	MERC	496 MAG HO	BRAVO 3	MPI	1.81	2.2	425	28'S B-3	48-823669A60/70A60
226	MERC	496 MAG HO-XZ	BRAVO 1	MPI			425		
226	VOLVO	4.3 GL	SX	2 BBL	1.79	1.89	190		
226	VOLVO	4.3 GL	DP	2 BBL	2.32	2.32	190		
226	VOLVO	5.0 GL	SX	2 BBL	1.6	1.79	220		
226	VOLVO	5.0 GL	DP	2 BBL	1.95	2.32	220	F6'S	3851496
226	VOLVO	4.3 GXi	SX	TBI	1.79	1.89	225		
226	VOLVO	4.3 GXi	DP	TBI	2.32	2.32	225		
226	VOLVO	5.7 GL	SX	2 BBL	1.51	1.6	260	17 AL RH	3850300
226	VOLVO	5.7 GL	DP	2 BBL	1.95	2.32	260	F6'S	3851496
226	VOLVO	5.0 GXi	SX	TBI	1.6	1.79	270	21 AL RH	3850302
226	VOLVO	5.0 GXi	DP	TBI	1.95	2.32	270	F6'S	3851496
226	VOLVO	5.7 Gi	SX	TBI	1.51	1.51	280		
226	VOLVO	5.7 Gi	DP	TBI	1.95	1.95	280	F6'S	3851496
226	VOLVO	5.7 GXi	SX	TBI	1.51	1.51	320	19 AL RH	3850301
226	VOLVO	5.7 GXi	DP	TBI	1.95	1.95	320	F7'S	3851497
226	VOLVO	8.1 Gi	DP	MFI	1.78	1.78	375	F9'S	3851499
226	VOLVO	8.1 GXi	DP	MFI	1.78	1.78	420	F8'S	3851498



MODEL SPECIFIC INFORMATION

240

COBALT BOATS - OWNER'S MANUAL

LAYOUT AND SPECIFICATIONS

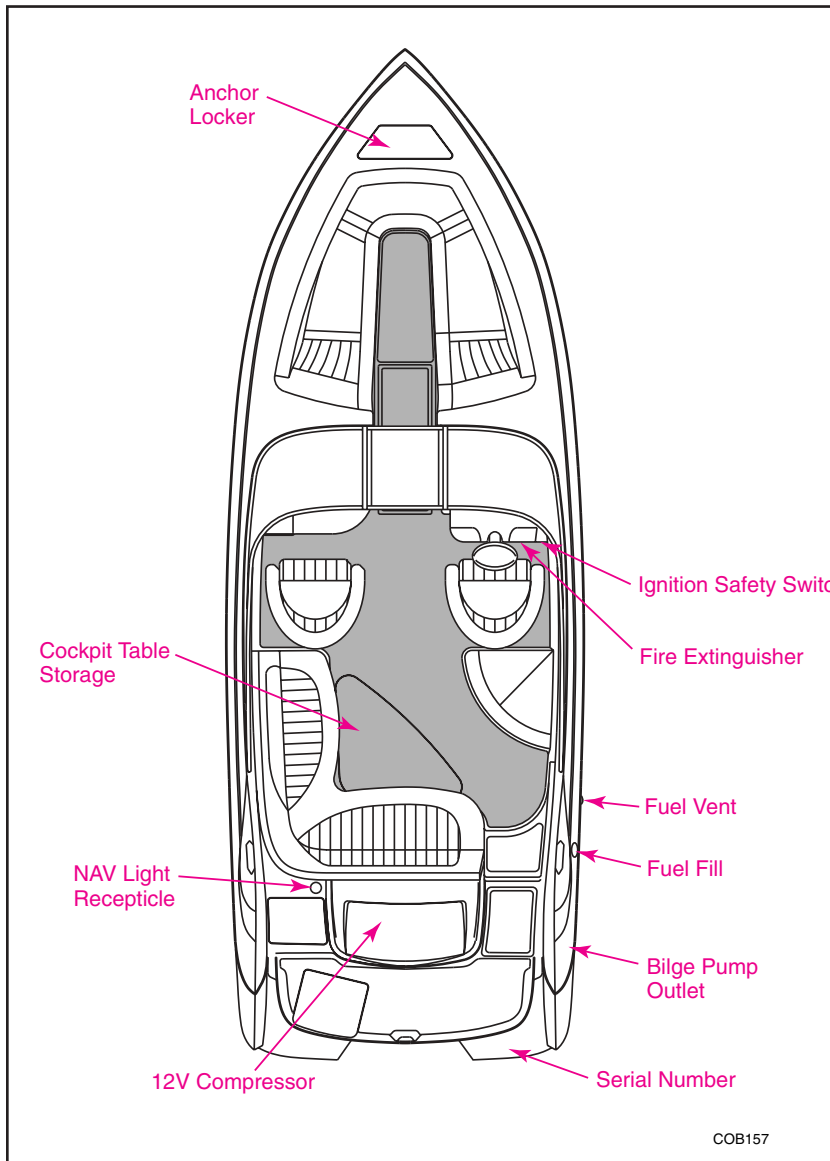

SPECIFICATIONS

Centerline23'9"	7.28 m
Beam8'6"	2.62 m
Dry Weight4240 lbs	1923 kg
Deadrise20 deg.	20 deg.
Fuel Capacity50 gal.	189 l
Draft (drive up)18.25"	46 cm
Draft (drive down)37"	93 cm
Freeboard (fwd)43"	109 cm
Freeboard (aft)38"	97 cm
Bridge Clearance57"	1.45 m
Fresh Water Capacity10 gal.	37.9 l
Capacity11 Persons	
Capacity by Weight1700 lbs	771 kg

COB157



CAPTAIN'S CHAIR ADJUSTMENT AND OPERATION

Your captain's chairs have the flip-up position for greater visibility and maneuverability while docking. You can sit on the raised cushion or stand in front of the cushion. Standing while driving your boat should only be done while maneuvering at an idle by an experienced driver.

The chairs are adjustable fore and aft and also rotate.

Rotation - Loosen the "T" handle next to the pedestal under the seat. Raise the lever on the opposite side of the pedestal. Rotate the seat to the desired position and lower the lever and tighten the knob to tighten the seat. Do not allow the seat to swing freely.

Fore and Aft adjustments - A handle under the front lip of the seat when raised allows the seat to move. Make sure the mechanism is properly engaged to prevent seat movement while the boat is underway.



WARNING

DRIVING WHILE STANDING UP IS AN EXTREMELY HAZARDOUS PRACTICE. DO NOT DRIVE WHILE STANDING AT SPEEDS GREATER THAN "IDLE SPEED."



CAUTION

ALL SEATS MUST BE IN A LOCKED/SECURED POSITION WHILE THE BOAT IS UNDERWAY.

INSTRUMENT PANEL

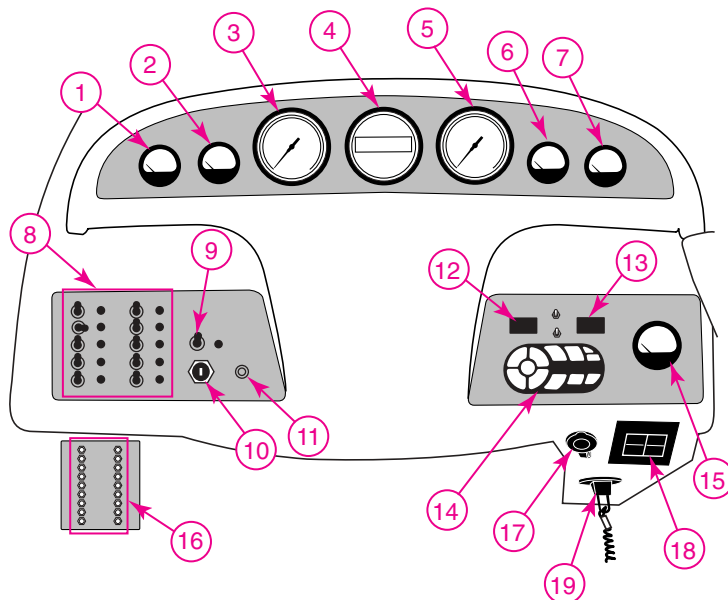

1. Fuel Gauge – Shows approximate amount of fuel remaining in tank.
2. Voltmeter – Shows the condition of charge in the battery. It only displays while the ignition is in the "ON" position. With the engine at idle or not running, it may show as low as 10 to 12 volts. With the engine running at cruising speeds and above, it should show 12 to 14 volts.
3. Speedometer (Miles Per Hour)
4. Compass – To aid in navigation. For operating information refer to the compass user's manual in your owner's packet.
5. Tachometer (Revolutions Per Minute)
6. Temperature Gauge – Temperature may fluctuate slightly while running. Maximum temperature may vary depending on type of engine.



7. Oil Pressure Gauge – Pressure can vary according to type of engine. It is normal for a hot engine to have low pressure at idle (depending on type of oil, pressure may drop as low as 10 PSI at idle).
8. Switch Panel – Power panel for miscellaneous accessories.
9. Blower Switch – Activates the engine compartment ventilation blower to remove explosive fumes from the area.
10. Ignition Key Switch
11. Horn Button – The horn itself is located under the deck.
12. Air/Water Temperature Gauge – Moving the toggle switch below the gauge allows you to go between air and water temperature readings. The gauge will display AIR and WATER to indicate which temperature source is in use.
13. Depth Sounder – Your Cobalt is equipped with a depth sounder. To see your options - shallow, deep, keel depth and units - toggle switch to down position. To set each option to desired reading toggle switch to up position. Consult your Cobalt Dealer for further information.
14. Stereo Remote Control (Optional) – Provides remote control of the stereo system from the helm.
15. Trim Gauge – Shows the position of the drive unit in reference to the bottom of the boat.
16. Circuit Breaker Panel – Push circuit breaker buttons to reset if necessary. If a button continues to pop out consult your Cobalt Dealer.
17. 12-Volt Accessory Power Receptacle – Provides electricity to operate 12 VDC accessory items.
18. Trim Tab Switches (Optional) – Activate the port and starboard trim tabs.
19. Ignition Safety Switch – Always attach the lanyard to your person. If you leave the driver's station the lanyard will immediately shut off the ignition preventing the boat from moving under power.

EXTENDED SWIM PLATFORM – OPTIONAL

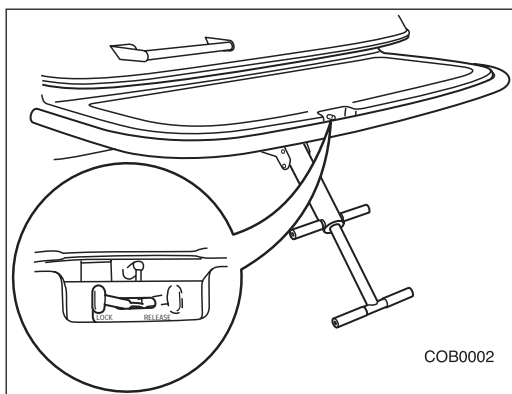

The swim platform was designed for use by people – not for the storage of personal equipment. Maximum platform weight capacity is 800 pounds. If the swim platform is removed the boat will not pass Coast Guard inspection, and the boat cannot be boarded until a boarding ladder has been installed on the swim deck. To purchase a boarding ladder consult your Cobalt Dealer.



EXTENDED SWIM PLATFORM MUST BE ATTACHED WHILE BOAT IS IN USE TO AVOID POSSIBLE INJURY OR DROWNING. SWIM LADDER IS ATTACHED TO THE PLATFORM. REMOVABLE FEATURE IS FOR BOAT STORAGE ONLY.



WARNING

DO NOT OCCUPY EXTENDED SWIM PLATFORM WHILE ENGINE IS RUNNING OR ENGAGED. PROPELLER CONTACT MAY CAUSE SEVERE INJURY OR FATALITY. ALL GASOLINE POWERED ENGINES PRODUCE CARBON MONOXIDE (CO). CO IS COLORLESS, ODORLESS, AND DANGEROUS. DIRECT AND PROLONGED EXPOSURE TO CO WILL CAUSE BRAIN DAMAGE OR DEATH.

GALLEY – OPTIONAL

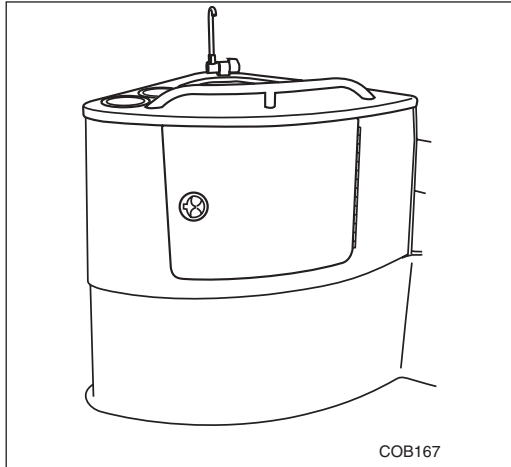

To operate the galley sink turn the pump switch located next to the pump inside the galley door to the ON position.

WINDSHIELD HOOK

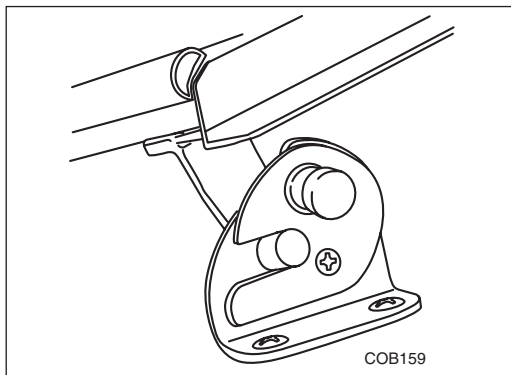

To open the windshield make sure the vertical slots in the mechanism are aligned. Swing the windshield open until the windshield post falls into the vertical slots and the mechanism locks.

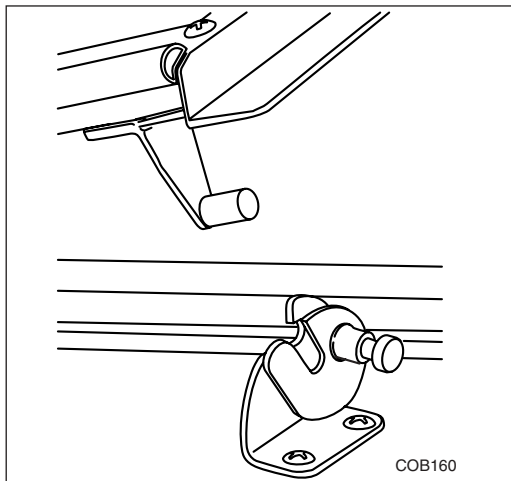

To close the windshield release the locking mechanism by pulling the forward-facing button. Swing the windshield into place.



COCKPIT DINETTE TABLE WITH FILLER CUSHION

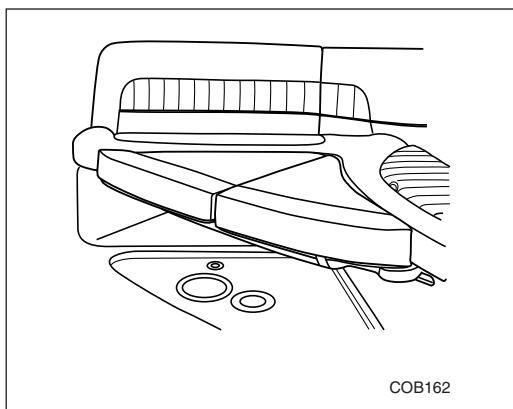

Position the dinette table on the stainless support rails located beneath the cockpit rear seating. Secure the table to the support rails by snapping the straps, located on the underside of the table, around the rails and to the underside of the table. Position the cushion on table. Secure the cushion to the table by snapping the straps to the front-edge underside of the table.

HEAD COMPARTMENT

1. Make sure the head compartment door assembly is closed and latched while the boat is underway. Do not allow to swing freely.
2. For operation of the porti potti, pump out or macerator, please check the manuals supplied in your owner's packet. Refer to page 69 of this manual for more information.

WATER SYSTEM

If your Cobalt is equipped with an optional transom shower, standard or optional galley, the system allows for a 10-gallon capacity water system. A 12VDC water pump operates the system. It is necessary for the ship's batteries to be turned ON for the water system to operate. Consult your Cobalt Dealer for winterization requirements.

To clean the water tank, the manufacturer recommends adding 1/4 cup of baking soda into the tank and allowing the tank to stand for one day, then flushing the tank twice. If this is not sufficient to clean the tank, replace the baking soda with 2 tablespoons of bleach and repeat the procedure.

ANCHOR LIGHT

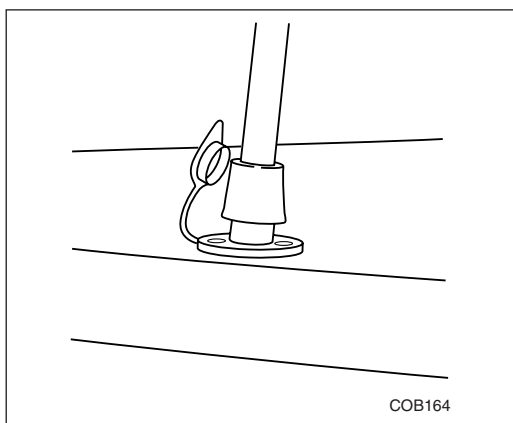

To install anchor light insert pole into socket and turn clockwise until it locks into place.



TELESCOPING ANCHOR LIGHT – OPTIONAL

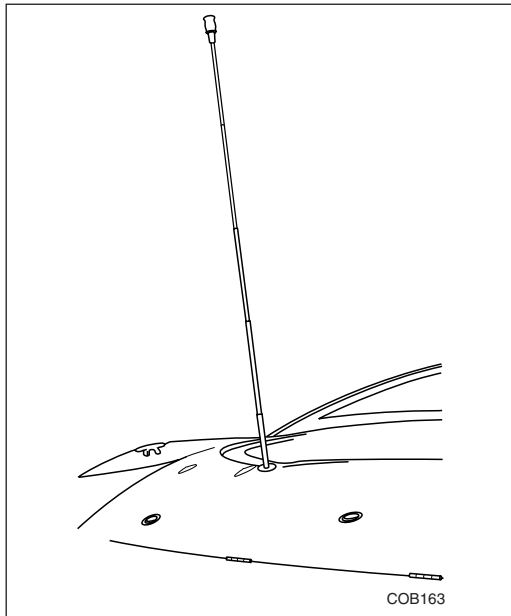

To activate, turn on the navigation light switch. The anchor light will first raise into position, then illuminate. When the light switch is turned off, the light will immediately turn off and after a 1.5 second computer check, the pole will automatically retract into its below-deck storage position. The top of the lens will be flush with the top of the deck ring. If the light does not retract automatically, do not force down, contact your Cobalt Dealer.

TELESCOPING BOARDING LADDER

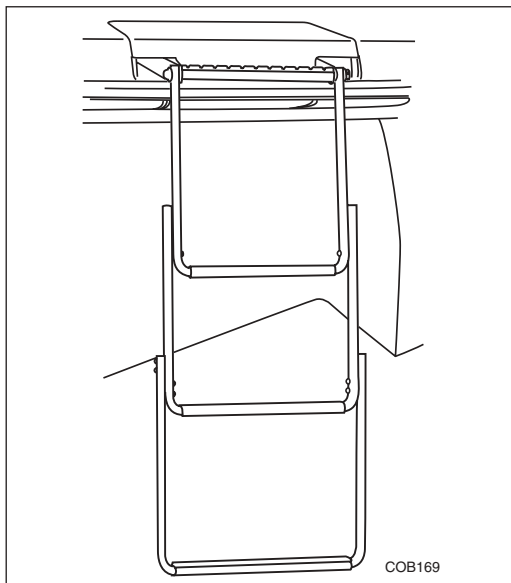

THIS LADDER MUST ONLY BE USED WHILE ENGINE IS OFF. (See warning label section). Be sure ladder is raised and secured prior to starting engine. Caution should be used while using this ladder.

Telescoping ladder is covered by ladder lid. Lift ladder lid to access ladder. Lift up on front of ladder to place overboard and telescope to full length. Use caution to prevent pinching fingers when stowing ladder.



WARNING

DO NOT USE BOARDING LADDER WHILE ENGINE IS RUNNING.



CAUTION

THE STERN DRIVE UNIT HAS MANY SHARP EDGES, ESPECIALLY THE PROPELLER. EXERCISE CAUTION WHEN NEAR THE STERN DRIVE UNIT. ALWAYS MAKE SURE THE BOARDING LADDER IS PROPERLY STOWED AND THERE IS NO ONE IN THE AREA BEHIND THE BOAT BEFORE STARTING THE ENGINE AND ENGAGING THE SHIFT MECHANISM.



CARE FOR YOUR WOOD (WATERFALL BUBINGA) DASH

- Wipe the wood surface clean with a water-moistened soft cloth. For stubborn dirt and stains use a small amount of mild non-abrasive detergent (Dove, Dawn, etc.) on a moistened cloth and gently clean the area.
- Wipe surface dry with a soft non-abrasive cloth.
- Avoid flushing the wood trim with water.
- Do not use Armor All or other marine protectants.
- Apply a light coat of non-abrasive Carnauba paste to protect the surface.

MOTOR BOX ASSEMBLY

The motor box raises and lowers manually. Do not allow to slam shut when closing.

COCKPIT DINETTE TABLE

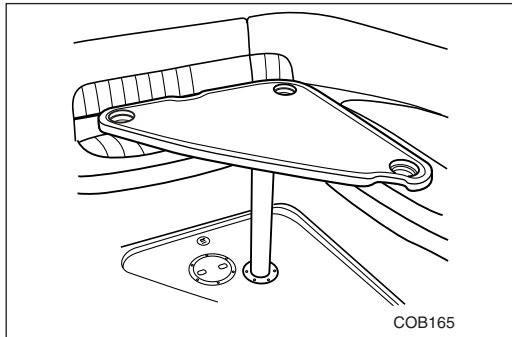

The dinette table leg is stored in the bench seat cushion storage compartment. Insert bottom of leg into recessed table base in floor. Insert top of leg into mount on underside of table. The table turns to allow free movement in the seating area.

SKI TOWER - OPTIONAL

To lay the tower down, first remove the lower aft hand knobs from the tower, making sure not to let it fall aft. Second, slightly loosen the front knobs but do not remove. Gently roll the tower forward over the windshield allowing it to rest on the top of the bow flip back seats. Some protection should be used between the tower and upholstery to prevent damage. Tighten the forward knobs. When the tower is upright, the hand knobs should be checked for tightness periodically.

COCKPIT HEATER - OPTIONAL

To winterize, remove the two 5/8" cockpit heater hoses from the engine. Pump antifreeze into one hose until entire heater system is filled.



PERFECT PASS - OPTIONAL

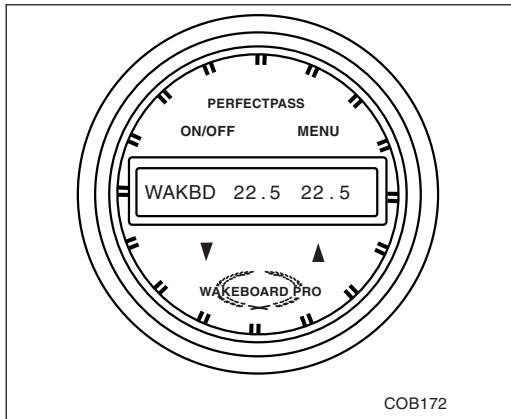

To operate the Perfect Pass speed control system set desired speed on Perfect Pass. Once your boat reaches the set speed Perfect Pass takes over and holds the speed constant. For additional operating information refer to operator's manual.

AIR COMPRESSOR - OPTIONAL

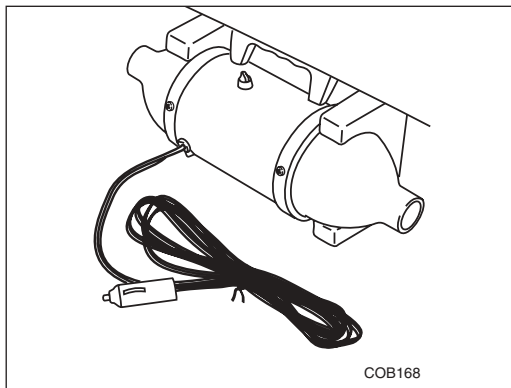

A high volume air pump is conveniently located in the aft deck storage compartment to inflate your favorite water toys. Plug into the accessory receptacle on the dash or in the air compressor area.



ELECTRICAL WIRING HARNESS

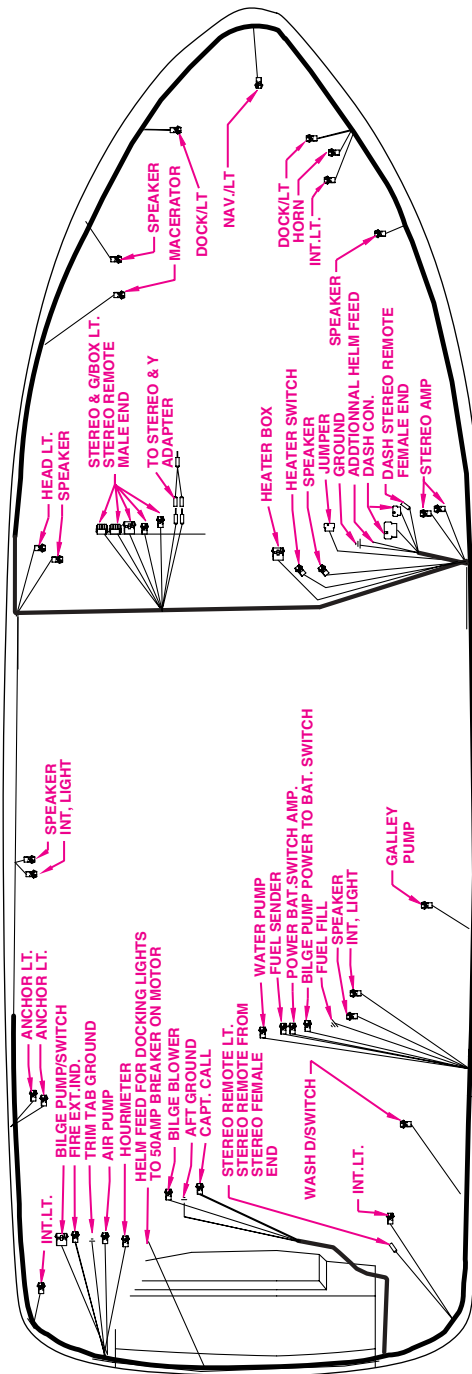

COB190



FUEL ROUTING

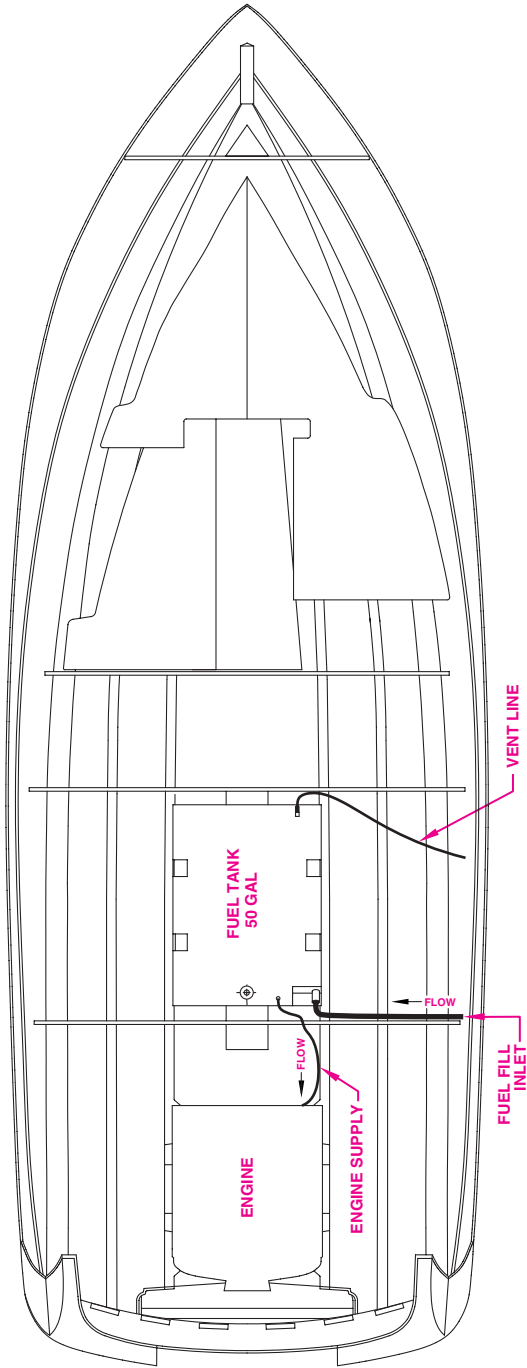

COB191



FRESH AND GRAY WATER PLUMBING

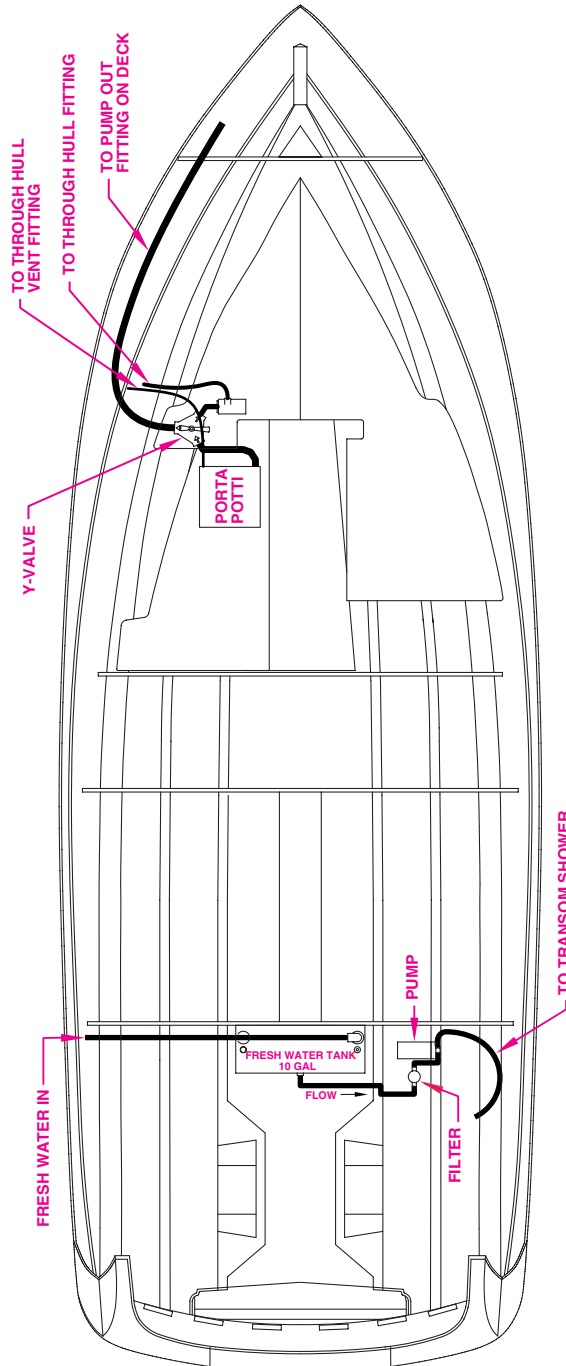

COB192



PROPELLER APPLICATION CHART

Model	Mfgr.	Engine	Drive	Fuel system	Std. Ratio	Optional Ratio	Php	Propeller Description	Mfgr. Part Number
240	MERC	4.3 L MPI	ALPHA	MPI	1.62	1.81	220		
240	MERC	4.3 L MPI	BRAVO 3	MPI	2.2	2.43	220		
240	MERC	5.0 L	ALPHA	2 BBL	1.62	1.81	220		
240	MERC	5.0 L	BRAVO 1	2 BBL	1.65	1.65	220		
240	MERC	5.0 L	BRAVO 3	2 BBL	2.2	2.43	220		
240	MERC	5.7 L	ALPHA	2 BBL	1.47	1.62	250		
240	MERC	5.7 L	BRAVO 1	2 BBL	1.65	1.65	250		
240	MERC	5.7 L	BRAVO 3	2 BBL	2.2	2.43	250		
240	MERC	5.0 L MPI	ALPHA	MPI	1.47	1.62	260		
240	MERC	5.0 L MPI	BRAVO 1	MPI	1.65	1.65	260		
240	MERC	5.0 L MPI	BRAVO 3	MPI	2.2	2.43	260		
240	MERC	350 MAG MPI	ALPHA	MPI	1.47	1.62	300		
240	MERC	350 MAG MPI	BRAVO 1	MPI	1.5	1.65	300		
240	MERC	350 MAG MPI	BRAVO 3	MPI	2.0	2.2	300	24'S B-3	48-823665A60/66A60
240	MERC	350 MAG MPI-HZN	BRAVO 3	MPI			300	24'S B-3	48-823665A60/66A60
240	MERC	6.2 MX MPI	BRAVO 1	MPI	1.65	1.65	320	21 MIR RH	48-13702A46
240	MERC	6.2 MX MPI	BRAVO 3	MPI	2.2	2.43	320	26'S B-3	48-823667A60/68A60
240	MERC	496 MAG MPI	BRAVO 1	MPI	1.50	1.65	375	21 MIR RH	48-13702A46
240	MERC	496 MAG MPI	BRAVO 3	MPI	1.81	2.2	375	26'S B-3	48-823667A60/68A60
240	MERC	496 MAG HO	BRAVO 1	MPI	1.50	1.65	425	23 MIR RH	48-13704A46
240	MERC	496 MAG HO	BRAVO 3	MPI	1.81	2.2	425	26'S B-3	48-823667A60/68A60
240	MERC	496 MAG HO-XZ	BRAVO 1	MPI			425		
240	VOLVO	5.0 GL	SX	2 BBL	1.6	1.79	220		
240	VOLVO	5.0 GL	DP	2 BBL	1.95	2.32	220		
240	VOLVO	5.7 GL	SX	2 BBL	1.51	1.6	260		
240	VOLVO	5.7 GL	DP	2 BBL	1.95	2.32	260		
240	VOLVO	5.0 GXi	SX	TBI	1.6	1.79	270		
240	VOLVO	5.0 GXi	DP	TBI	1.95	2.32	270		
240	VOLVO	5.7 Gi	SX	TBI	1.51	1.51	280		
240	VOLVO	5.7 Gi	DP	TBI	1.95	1.95	280	F6'S	3851496
240	VOLVO	5.7 GXi	SX	TBI	1.51	1.51	320	19 AL RH	3850301
240	VOLVO	5.7 GXi	DP	TBI	1.95	1.95	320	F6'S	3851496
240	VOLVO	8.1 Gi	DP	MFI	1.78	1.78	375	F7'S	3851497
240	VOLVO	8.1 GXi	DP	MFI	1.78	1.78	420	F6'S	3851496



240SD

MODEL SPECIFIC INFORMATION

LAYOUT AND SPECIFICATIONS

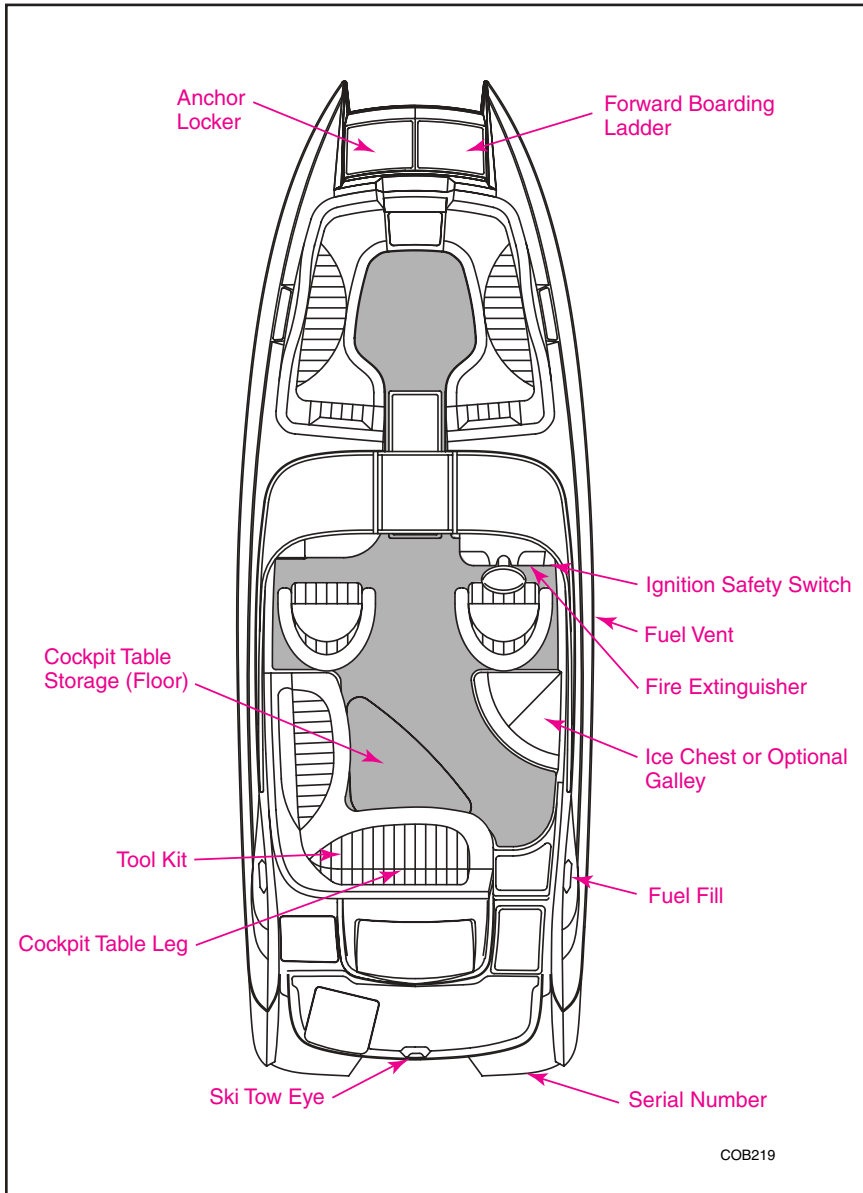

SPECIFICATIONS

Style	Bowrider	
Centerline.....	23'9"	7.28 m
Beam.....	8'6"	2.62 m
Dry Weight	4240 lbs	1923 kg
Deadrise.....	17 deg.	17 deg.
Fuel Capacity	50 gal.	189 l
Draft (drive up)	18.25"	46 cm
Draft (drive down)	37"	93 cm
Freeboard (fwd).....	43"	109 cm
Freeboard (aft)	38"	97 cm
Bridge Clearance	57"	1.45 m
Fresh Water Capacity.....	10 gal.	37.9 l
Capacity	11 Persons	
Capacity by Weight	1700 lbs	771 kg

COB219



CAPTAIN'S CHAIR ADJUSTMENT AND OPERATION

Your captain's chairs have the flip-up position for greater visibility and maneuverability while docking. You can sit on the raised cushion or stand in front of the cushion. Standing while driving your boat should only be done while maneuvering at an idle by an experienced driver.

The chairs are adjustable fore and aft and also rotate.

Rotation - Loosen the "T" handle next to the pedestal under the seat. Raise the lever on the opposite side of the pedestal. Rotate the seat to the desired position and lower the lever and tighten the knob to tighten the seat. Do not allow the seat to swing freely.

Fore and Aft adjustments - A handle under the front lip of the seat when raised allows the seat to move. Make sure the mechanism is properly engaged to prevent seat movement while the boat is underway.



WARNING

DRIVING WHILE STANDING UP IS AN EXTREMELY HAZARDOUS PRACTICE. DO NOT DRIVE WHILE STANDING AT SPEEDS GREATER THAN "IDLE SPEED."



CAUTION

ALL SEATS MUST BE IN A LOCKED/SECURED POSITION WHILE THE BOAT IS UNDERWAY.

INSTRUMENT PANEL

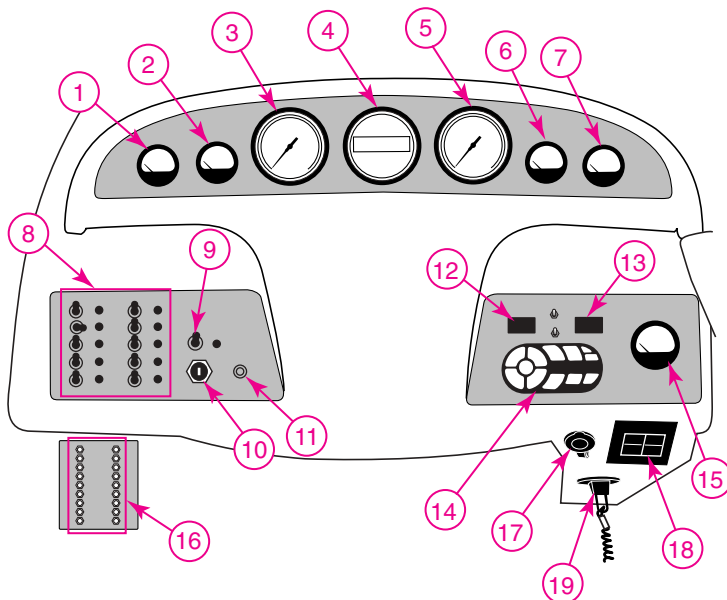

1. Fuel Gauge – Shows approximate amount of fuel remaining in tank.
2. Voltmeter – Shows the condition of charge in the battery. It only displays while the ignition is in the "ON" position. With the engine at idle or not running, it may show as low as 10 to 12 volts. With the engine running at cruising speeds and above, it should show 12 to 14 volts.
3. Speedometer (Miles Per Hour)
4. Compass – To aid in navigation. For operating information refer to the compass user's manual in your owner's packet.
5. Tachometer (Revolutions Per Minute)
6. Temperature Gauge – Temperature may fluctuate slightly while running. Maximum temperature may vary depending on type of engine.



7. Oil Pressure Gauge – Pressure can vary according to type of engine. It is normal for a hot engine to have low pressure at idle (depending on type of oil, pressure may drop as low as 10 PSI at idle).
8. Switch Panel – Power panel for miscellaneous accessories.
9. Blower Switch – Activates the engine compartment ventilation blower to remove explosive fumes from the area.
10. Ignition Key Switch
11. Horn Button – The horn itself is located under the deck.
12. Air/Water Temperature Gauge – Moving the toggle switch below the gauge allows you to go between air and water temperature readings. The gauge will display AIR and WATER to indicate which temperature source is in use.
13. Depth Sounder – Your Cobalt is equipped with a depth sounder. To see your options - shallow, deep, keel depth and units - toggle switch to down position. To set each option to desired reading toggle switch to up position. Consult your Cobalt Dealer for further information.
14. Stereo Remote Control (Optional) – Provides remote control of the stereo system from the helm.
15. Trim Gauge – Shows the position of the drive unit in reference to the bottom of the boat.
16. Circuit Breaker Panel – Push circuit breaker buttons to reset if necessary. If a button continues to pop out consult your Cobalt Dealer.
17. 12-Volt Accessory Power Receptacle – Provides electricity to operate 12 VDC accessory items.
18. Trim Tab Switches (Optional) – Activate the port and starboard trim tabs.
19. Ignition Safety Switch – Always attach the lanyard to your person. If you leave the driver's station the lanyard will immediately shut off the ignition preventing the boat from moving under power.

EXTENDED SWIM PLATFORM – OPTIONAL

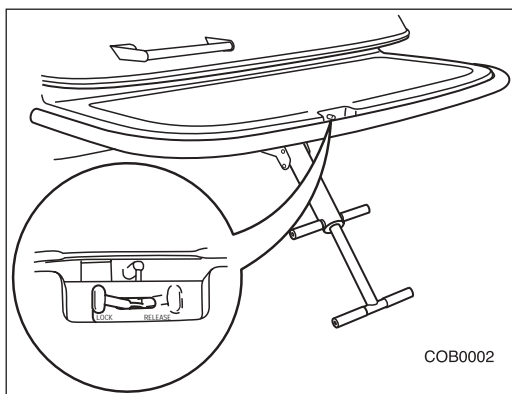

The swim platform was designed for use by people – not for the storage of personal equipment. Maximum platform weight capacity is 800 pounds. If the swim platform is removed the boat will not pass Coast Guard inspection, and the boat cannot be boarded until a boarding ladder has been installed on the swim deck. To purchase a boarding ladder consult your Cobalt Dealer.



WARNING

EXTENDED SWIM PLATFORM MUST BE ATTACHED WHILE BOAT IS IN USE TO AVOID POSSIBLE INJURY OR DROWNING. SWIM LADDER IS ATTACHED TO THE PLATFORM. REMOVABLE FEATURE IS FOR BOAT STORAGE ONLY.



WARNING

DO NOT OCCUPY EXTENDED SWIM PLATFORM WHILE ENGINE IS RUNNING OR ENGAGED. PROPELLER CONTACT MAY CAUSE SEVERE INJURY OR FATALITY. ALL GASOLINE POWERED ENGINES PRODUCE CARBON MONOXIDE (CO). CO IS COLORLESS, ODORLESS, AND DANGEROUS. DIRECT AND PROLONGED EXPOSURE TO CO WILL CAUSE BRAIN DAMAGE OR DEATH.

GALLEY – OPTIONAL

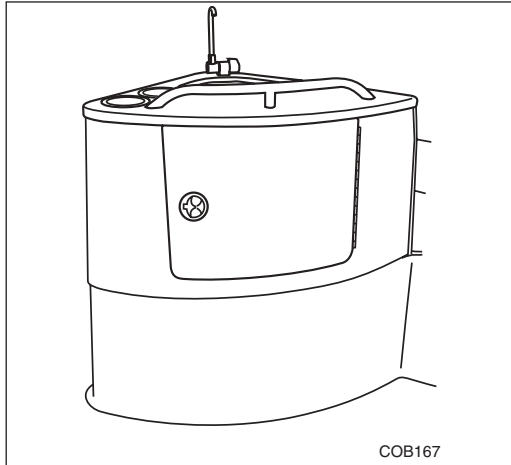

To operate the galley sink turn the pump switch located next to the pump inside the galley door to the ON position.

WINDSHIELD HOOK

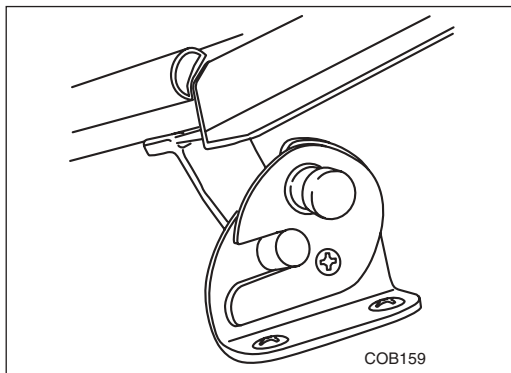

To open the windshield make sure the vertical slots in the mechanism are aligned. Swing the windshield open until the windshield post falls into the vertical slots and the mechanism locks.

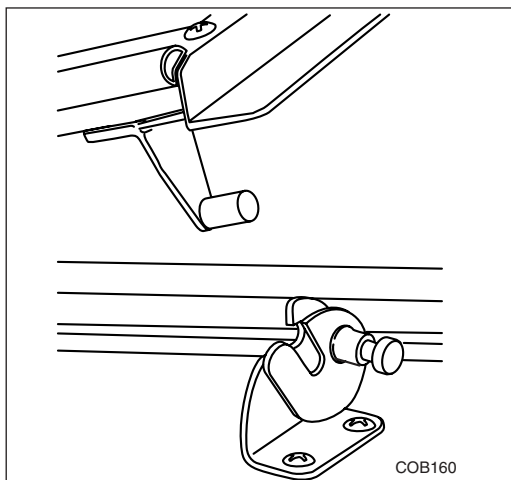

To close the windshield release the locking mechanism by pulling the forward-facing button. Swing the windshield into place.



COCKPIT DINETTE TABLE WITH FILLER CUSHION

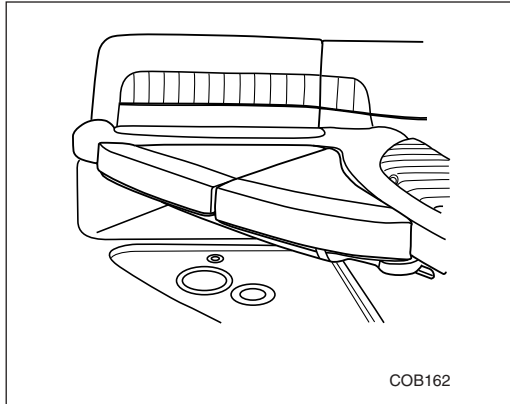

Position the dinette table on the stainless support rails located beneath the cockpit rear seating. Secure the table to the support rails by snapping the straps, located on the underside of the table, around the rails and to the underside of the table. Position the cushion on table. Secure the cushion to the table by snapping the straps to the front-edge underside of the table.

HEAD COMPARTMENT

1. Make sure the head compartment door assembly is closed and latched while the boat is underway. Do not allow to swing freely.
2. For operation of the porti potti, pump out or macerator, please check the manuals supplied in your owner's packet. Refer to page 69 of this manual for more information.

WATER SYSTEM

If your Cobalt is equipped with an optional transom shower, standard or optional galley, the system allows for a 10-gallon capacity water system. A 12VDC water pump operates the system. It is necessary for the ship's batteries to be turned ON for the water system to operate. Consult your Cobalt Dealer for winterization requirements.

To clean the water tank, the manufacturer recommends adding 1/4 cup of baking soda into the tank and allowing the tank to stand for one day, then flushing the tank twice. If this is not sufficient to clean the tank, replace the baking soda with 2 tablespoons of bleach and repeat the procedure.

ANCHOR LIGHT

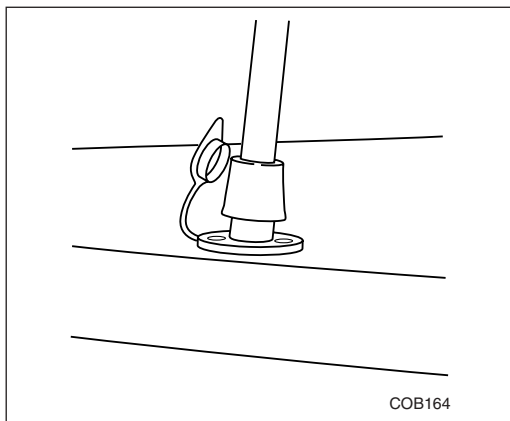

To install anchor light insert pole into socket and turn clockwise until it locks into place.



TELESCOPING BOARDING LADDER

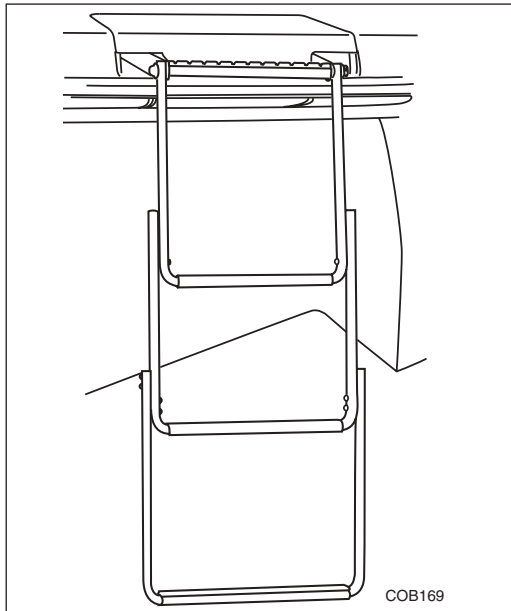

THIS LADDER MUST ONLY BE USED WHILE ENGINE IS OFF. (See warning label section). Be sure ladder is raised and secured prior to starting engine. Caution should be used while using this ladder.

Telescoping ladder is covered by ladder lid. Lift ladder lid to access ladder. Lift up on front of ladder to place overboard and telescope to full length. Use caution to prevent pinching fingers when stowing ladder.



WARNING

DO NOT USE BOARDING LADDER WHILE ENGINE IS RUNNING.



CAUTION

THE STERN DRIVE UNIT HAS MANY SHARP EDGES, ESPECIALLY THE PROPELLER. EXERCISE CAUTION WHEN NEAR THE STERN DRIVE UNIT. ALWAYS MAKE SURE THE BOARDING LADDER IS PROPERLY STOWED AND THERE IS NO ONE IN THE AREA BEHIND THE BOAT BEFORE STARTING THE ENGINE AND ENGAGING THE SHIFT MECHANISM.

SKI TOWER - OPTIONAL

To lay the tower down, first remove the lower aft hand knobs from the tower, making sure not to let it fall aft. Second, slightly loosen the front knobs but do not remove. Gently roll the tower forward over the windshield, allowing it to rest on the top of the bow flip back seats. Some protection should be used between the tower and upholstery to prevent damage. Tighten the forward knobs. When the tower is upright, the hand knobs should be checked for tightness periodically.



CARE FOR YOUR WOOD (WATERFALL BUBINGA) DASH

- Wipe the wood surface clean with a water-moistened soft cloth. For stubborn dirt and stains use a small amount of mild non-abrasive detergent (Dove, Dawn, etc.) on a moistened cloth and gently clean the area.
- Wipe surface dry with a soft non-abrasive cloth.
- Avoid flushing the wood trim with water.
- Do not use Armor All or other marine protectants.
- Apply a light coat of non-abrasive Carnauba paste to protect the surface.

MOTOR BOX ASSEMBLY

The motor box raises and lowers manually. Do not allow to slam shut when closing.

COCKPIT DINETTE TABLE

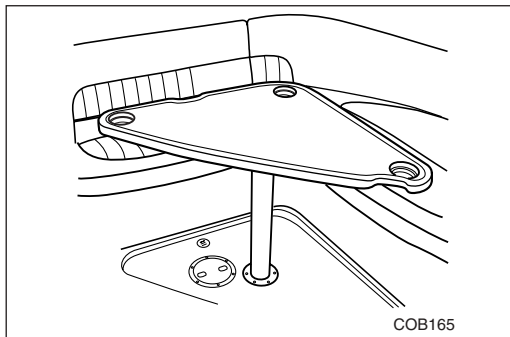

The dinette table leg is stored in the bench seat cushion storage compartment. Insert bottom of leg into recessed table base in floor. Insert top of leg into mount on underside of table. The table turns to allow free movement in the seating area.

COCKPIT HEATER - OPTIONAL

To winterize, remove the two 5/8" cockpit heater hoses from the engine. Pump antifreeze into one hose until entire heater system is filled.

PERFECT PASS - OPTIONAL

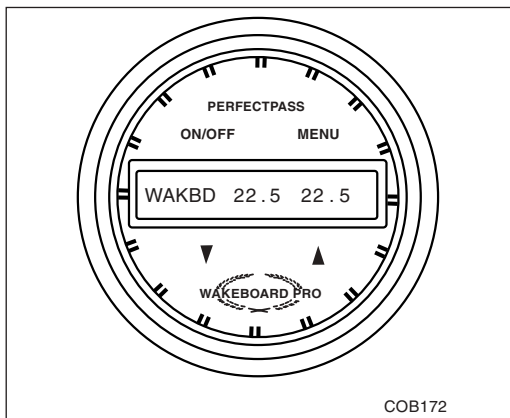

To operate the Perfect Pass speed control system set desired speed on Perfect Pass. Once your boat reaches the set speed Perfect Pass takes over and holds the speed constant. For additional operating information refer to operator's manual.



AIR COMPRESSOR - OPTIONAL

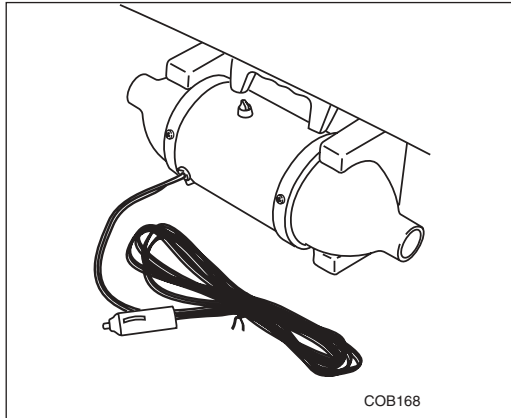

A high volume air pump is conveniently located in the aft deck storage compartment to inflate your favorite water toys. Plug into the accessory receptacle on the dash or in the air compressor area.



FUEL ROUTING

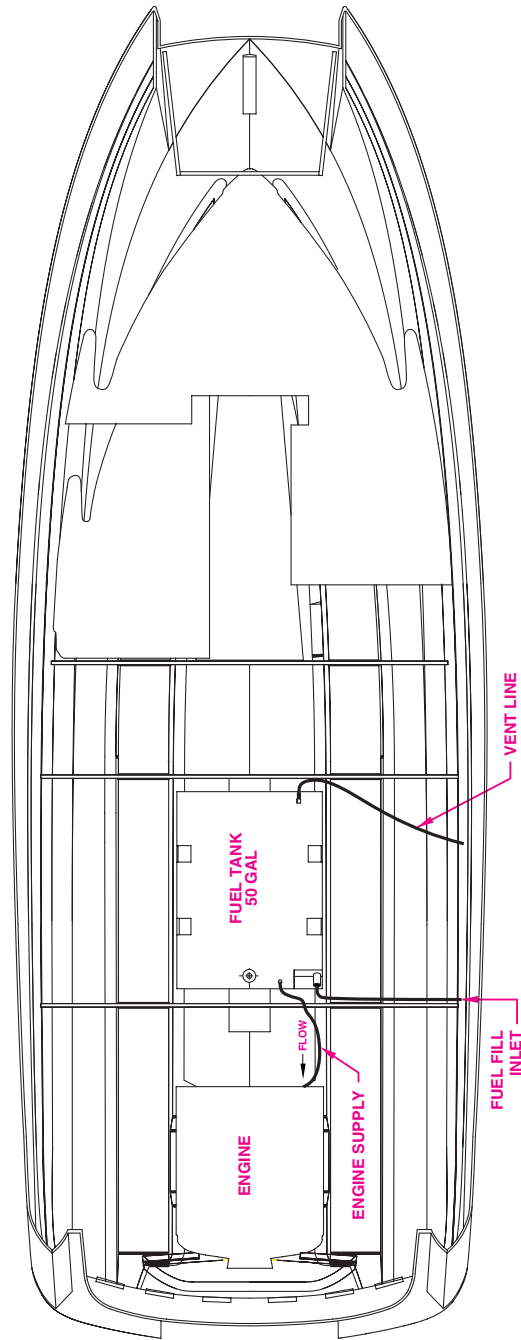

COB194



FRESH AND GRAY WATER PLUMBING

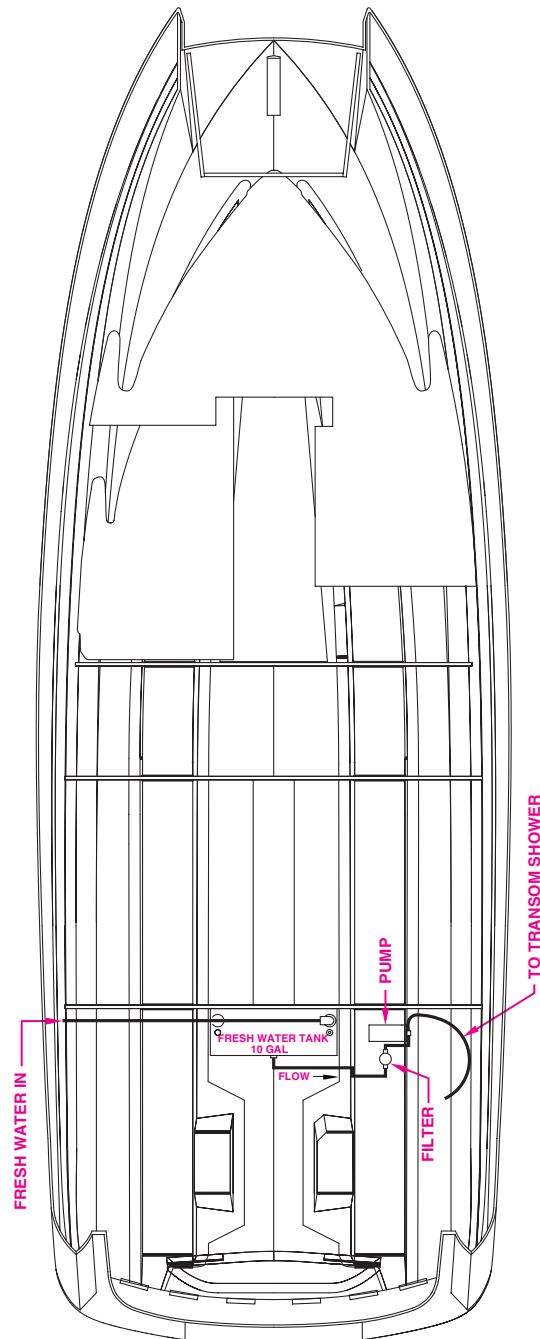

COB195



PROPELLER APPLICATION CHART

Model	Mfgr.	Engine	Drive	Fuel system	Std. Ratio	Optional Ratio	Php	Propeller Description	Mfgr. Part Number
240SD	MERC	4.3 L MPI	ALPHA	MPI	1.62	1.81	220		
240SD	MERC	4.3 L MPI	BRAVO 3	MPI	2.2	2.43	220		
240SD	MERC	5.0 L	ALPHA	2 BBL	1.62	1.81	220		
240SD	MERC	5.0 L	BRAVO 1	2 BBL	1.65	1.65	220		
240SD	MERC	5.0 L	BRAVO 3	2 BBL	2.2	2.43	220		
240SD	MERC	5.7 L	ALPHA	2 BBL	1.47	1.62	250		
240SD	MERC	5.7 L	BRAVO 1	2 BBL	1.65	1.65	250		
240SD	MERC	5.7 L	BRAVO 3	2 BBL	2.2	2.43	250		
240SD	MERC	5.0 L MPI	ALPHA	MPI	1.47	1.62	260		
240SD	MERC	5.0 L MPI	BRAVO 1	MPI	1.65	1.65	260		
240SD	MERC	5.0 L MPI	BRAVO 3	MPI	2.2	2.43	260		
240SD	MERC	350 MAG MPI	ALPHA	MPI	1.47	1.62	300		
240SD	MERC	350 MAG MPI	BRAVO 1	MPI	1.5	1.65	300		
240SD	MERC	350 MAG MPI	BRAVO 3	MPI	2.0	2.2	300	22'S B-3	48-823663A60/64A60
240SD	MERC	350 MAG MPI-HZN	BRAVO 3	MPI			300	22'S B-3	48-823663A60/64A60
240SD	MERC	6.2 MX MPI	BRAVO 1	MPI	1.65	1.65	320	19 MIR RH	48-13700A46
240SD	MERC	6.2 MX MPI	BRAVO 3	MPI	2.2	2.43	320	26'S B-3	48-823667A60/68A60
240SD	MERC	496 MAG MPI	BRAVO 1	MPI	1.50	1.65	375		
240SD	MERC	496 MAG MPI	BRAVO 3	MPI	1.81	2.2	375		
240SD	MERC	496 MAG HO	BRAVO 1	MPI	1.50	1.65	425		
240SD	MERC	496 MAG HO	BRAVO 3	MPI	1.81	2.2	425		
240SD	MERC	496 MAG HO-XZ	BRAVO 1	MPI			425		
240SD	VOLVO	5.0 GL	SX	2 BBL	1.6	1.79	220		
240SD	VOLVO	5.0 GL	DP	2 BBL	1.95	2.32	220		
240SD	VOLVO	5.7 GL	SX	2 BBL	1.51	1.6	260		
240SD	VOLVO	5.7 GL	DP	2 BBL	1.95	2.32	260		
240SD	VOLVO	5.0 GXi	SX	TBI	1.6	1.79	270		
240SD	VOLVO	5.0 GXi	DP	TBI	1.95	2.32	270		
240SD	VOLVO	5.7 Gi	SX	TBI	1.51	1.51	280		
240SD	VOLVO	5.7 Gi	DP	TBI	1.95	1.95	280	F6'S	3851496
240SD	VOLVO	5.7 GXi	SX	TBI	1.51	1.51	320		
240SD	VOLVO	5.7 GXi	DP	TBI	1.95	1.95	320	F6'S	3851496
240SD	VOLVO	8.1 Gi	DP	MFI	1.78	1.78	375	F8'S	3851498
240SD	VOLVO	8.1 GXi	DP	MFI	1.78	1.78	420		



MODEL SPECIFIC INFORMATION

COBALT BOATS - OWNER'S MANUAL

246

LAYOUT AND SPECIFICATIONS

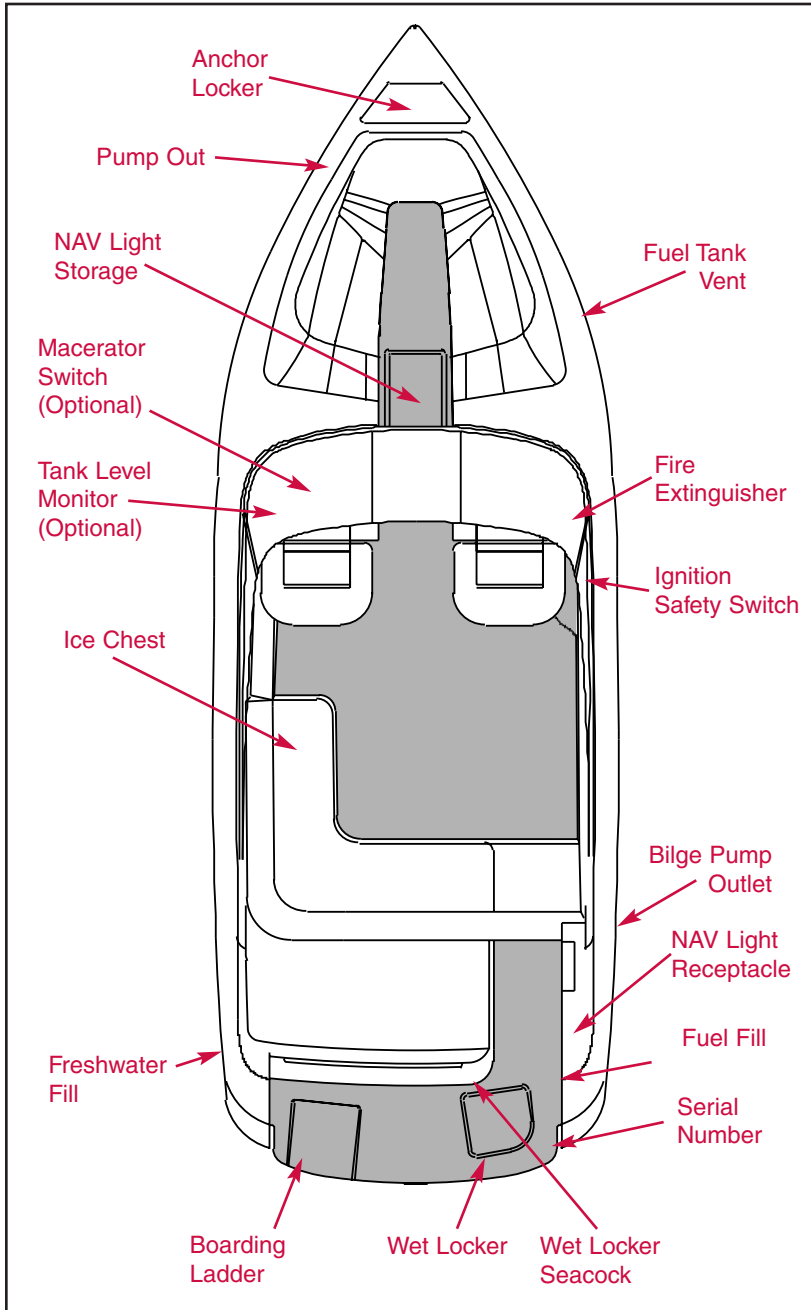

SPECIFICATIONS

Centerline24'4"	7.41 m
Beam8'6"	2.59 m
Dry Weight4100 lbs.	1860 kg
Deadrise20 deg.	20 deg.
Fuel Capacity70 gal.	265 L
Draft(drive up)17"	43 cm
Freeboard(fwd)34"	86 cm
Freeboard(aft)21"	53 cm
Transom Height43"	109 cm
Bridge Clearance		
(w/o nav light)54"	137 cm
Capacity12 Persons	
Capacity by Weight1700 lbs	771 kg



CAPTAIN’S CHAIR ADJUSTMENT AND OPERATION

Your captain’s chairs have the flip-up position for greater visibility and maneuverability while docking. You can sit on the raised cushion or stand in front of the cushion. Standing while driving your boat should only be done while maneuvering at an idle by an experienced driver.

The chairs are adjustable fore and aft and also rotate.

Rotation - Loosen the “T” handle next to the pedestal under the seat. Raise the lever on the opposite side of the pedestal. Rotate the seat to the desired position and lower the lever and tighten the knob to tighten the seat. Do not allow the seat to swing freely.

Fore and Aft adjustments - A handle under the front lip of the seat when raised allows the seat to move. Make sure the mechanism is properly engaged to prevent seat movement while the boat is underway.



WARNING

DRIVING WHILE STANDING UP IS AN EXTREMELY HAZARDOUS PRACTICE. DO NOT DRIVE WHILE STANDING AT SPEEDS GREATER THAN “IDLE SPEED.”



CAUTION

ALL SEATS MUST BE IN A LOCKED/SECURED POSITION WHILE THE BOAT IS UNDERWAY.

INSTRUMENT PANEL

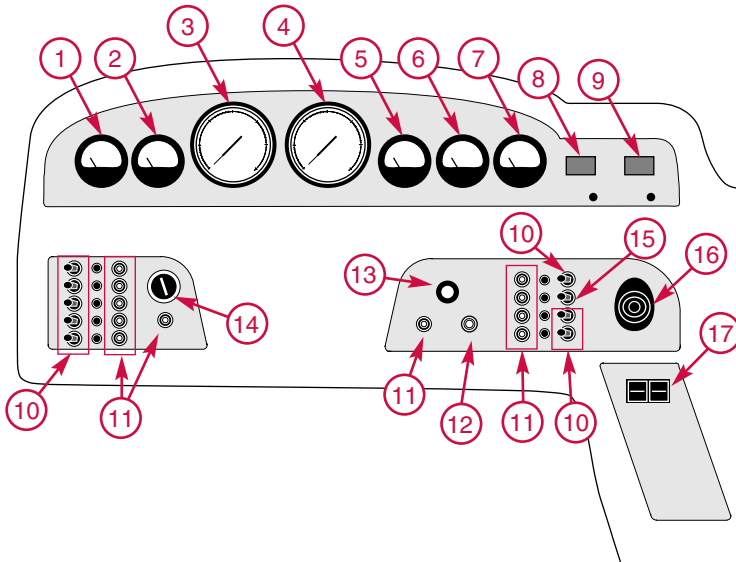

1. Fuel Gauge - shows approximate amount of fuel remaining in tank.
2. Voltmeter - shows the condition of charge in the battery. It only indicates while the ignition is in the “ON” position. With the engine at idle or not running, it may show as low as 10 to 12 volts. With the engine running at cruising speeds and above, it should show 12 to 14 volts.
3. Speedometer (Miles Per Hour)
4. Tachometer - (Revolutions Per Minute)
5. Temperature Gauge - Temperature may fluctuate slightly while running. Maximum temperature may vary depending on type of engine.



WARNING

SHOULD WATER TEMPERATURE REACH 180 DEGREES FAHRENHEIT, YOUR ENGINE IS OVERHEATING AND SHOULD BE CHECKED IMMEDIATELY FOR PROBABLE CAUSE.



6. Oil Pressure Gauge - Pressure can vary according to type of engine. It is normal for a hot engine to have low pressure at idle, (depending on type of oil, pressure may drop as low as 10 PSI at idle).
Please consult the engine owner's manual supplied with your boat concerning the oil pressure the engine in your boat should attain.
7. Trim Gauge - Shows the position of the drive unit in reference to the bottom of the boat.
8. Air/Water Temperature Gauge - Moving the toggle switch below the gauge allows you to go between air and water temperature readings. The gauge will display AIR and WATER to indicate which temperature source is in use.
9. Depth Sounder - Your Cobalt is equipped with a depth sounder. To see your options - shallow, deep, keel depth and units - toggle switch to down position. To set each option to desired reading toggle switch to up position. Consult your Cobalt Dealer for further information.
10. Two Position Switch - Controls equipment as labeled.
11. Circuit Breakers - Push to reset if necessary. If the button continues to pop out, consult your Authorized Cobalt Dealer.
12. Horn Button - The horn is located under the deck.
13. Dimmer Switch - Your Cobalt is equipped with a dimmer switch which controls the intensity of the dash lights including the compass light.
14. Ignition Key Switch
15. Three Position Exterior Light Switch NAV. position - navigation (running) lights, bow light and stern light. Center position - off. ANC. position - stern light only.



WARNING

NEVER OPERATE YOUR BOAT AT NIGHT WITHOUT ALL OF THE REQUIRED LIGHTS OPERATING. THIS INCLUDES BOW LIGHT AND REMOVABLE STERN LIGHT. MAKE SURE LIGHTS ARE NOT BLOCKED BY CANVAS OR OTHER OBSTACLES.

16. Stereo Remote Control
17. Trim Tabs (optional)

TELESCOPING BOARDING LADDER

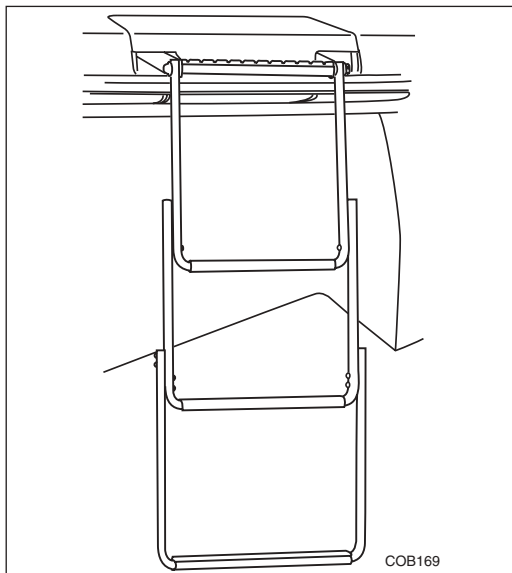

THIS LADDER MUST ONLY BE USED WHILE ENGINE IS OFF. (See warning label section). Be sure ladder is raised and secured prior to starting engine. Caution should be used while using this ladder.

Telescoping ladder is covered by ladder lid. Lift ladder lid to access ladder. Lift up on front of ladder to place overboard and telescope to full length. Use caution to prevent pinching fingers when stowing ladder.



WARNING

DO NOT USE BOARDING LADDER WHILE ENGINE IS RUNNING.



CAUTION

THE STERN DRIVE UNIT HAS MANY SHARP EDGES, ESPECIALLY THE PROPELLER. EXERCISE CAUTION WHEN NEAR THE STERN DRIVE UNIT. ALWAYS MAKE SURE THE BOARDING LADDER IS PROPERLY STOWED AND THERE IS NO ONE IN THE AREA BEHIND THE BOAT BEFORE STARTING THE ENGINE AND ENGAGING THE SHIFT MECHANISM.

HEAD COMPARTMENT

1. Make sure the head compartment door assembly is closed and latched while the boat is underway. Do not allow to swing freely.
2. For operation of the porti potti, pump out or macerator, please check the manuals supplied in your owner's packet. Refer to page 69 of this manual for more information.

EXTENDED SWIM PLATFORM – OPTIONAL

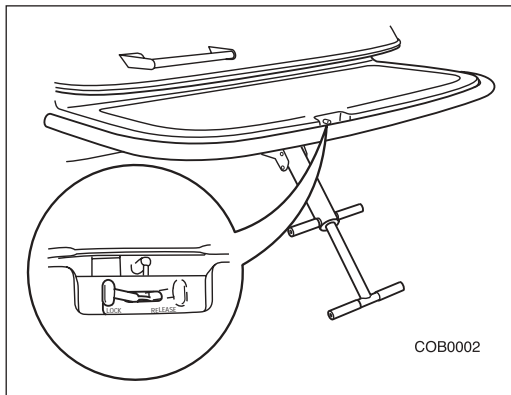

The swim platform was designed for use by people – not for the storage of personal equipment. Maximum platform weight capacity is 800 pounds. If the swim platform is removed the boat will not pass Coast Guard inspection, and the boat cannot be boarded until a boarding ladder has been installed on the swim deck. To purchase a boarding ladder consult your Cobalt Dealer.



WARNING

EXTENDED SWIM PLATFORM MUST BE ATTACHED WHILE BOAT IS IN USE TO AVOID POSSIBLE INJURY OR DROWNING. SWIM LADDER IS ATTACHED TO THE PLATFORM. REMOVABLE FEATURE IS FOR BOAT STORAGE ONLY.



WARNING

DO NOT OCCUPY EXTENDED SWIM PLATFORM WHILE ENGINE IS RUNNING OR ENGAGED. PROPELLER CONTACT MAY CAUSE SEVERE INJURY OR FATALITY. ALL GASOLINE POWERED ENGINES PRODUCE CARBON MONOXIDE (CO). CO IS COLORLESS, ODORLESS, AND DANGEROUS. DIRECT AND PROLONGED EXPOSURE TO CO WILL CAUSE BRAIN DAMAGE OR DEATH.

LADDER MUST ONLY BE USED WHILE THE ENGINE IS OFF. (See warning label section.) Be sure the ladder is raised and secured prior to starting engine. Exercise caution while using the ladder.



Use the release lever to release the ladder and telescope to full length. Lift ladder to retract and stow. Place release lever in the LOCK position. Use caution when stowing the ladder to prevent pinching fingers.



WARNING

DO NOT USE BOARDING LADDER WHILE ENGINE IS RUNNING.



CAUTION

THE STERN DRIVE UNIT HAS MANY SHARP EDGES, ESPECIALLY THE PROPELLER. EXERCISE CAUTION WHEN NEAR THE STERN DRIVE UNIT. ALWAYS MAKE SURE THE BOARDING LADDER IS PROPERLY STOWED AND THERE IS NO ONE IN THE AREA BEHIND THE BOAT BEFORE STARTING THE ENGINE AND ENGAGING THE SHIFT MECHANISM.

WINDSHIELD HOOK

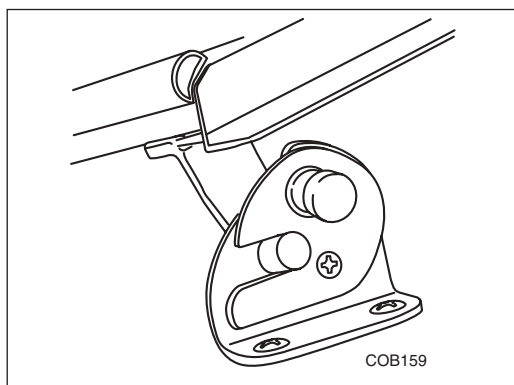

To open the windshield make sure the vertical slots in the mechanism are aligned. Swing the windshield open until the windshield post falls into the vertical slots and the mechanism locks.

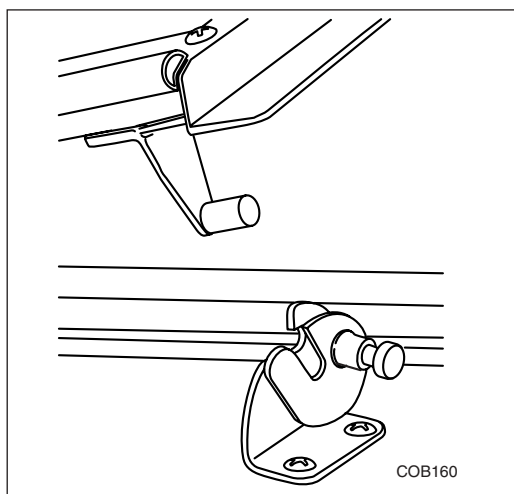

To close the windshield release the locking mechanism by pulling the forward-facing button. Swing the windshield into place.

AFT WALK-THRU FILLER CUSHIONS – OPTIONAL

The starboard rear walk-thru area can be converted into a large sundeck pad over the motor box by installing aft filler cushions. Snap the bottom cushion in place. Secure the barrel bolts on the underside of the extended pad before using.



WATER SYSTEM

If your Cobalt is equipped with an optional transom shower, standard or optional galley, the system allows for a 10-gallon capacity water system. A 12VDC water pump operates the system. It is necessary for the ship's batteries to be turned ON for the water system to operate. Consult your Cobalt Dealer for winterization requirements.

To clean the water tank, the manufacturer recommends adding 1/4 cup of baking soda into the tank and allowing the tank to stand for one day, then flushing the tank twice. If this is not sufficient to clean the tank, replace the baking soda with 2 tablespoons of bleach and repeat the procedure.

SKI TOWER - OPTIONAL

The Stainless Steel Ski Tower is designed to rotate forward for storing where overhead height is an issue:

- Remove 5/16" allen head screws from both aft deck mounts. 5/16" allen head driver is provided in your boat bag.
- Loosen the forward two 5/16" allen head screws.
- Carefully rotate Ski Tower forward until it rests on deck area just forward of windshield.
- Tighten forward two 5/16" Allen screws.



DANGER

SKI TOWER IS DESIGNED FOR A SINGLE SKIER ONLY.

TELESCOPING ANCHOR LIGHT – OPTIONAL

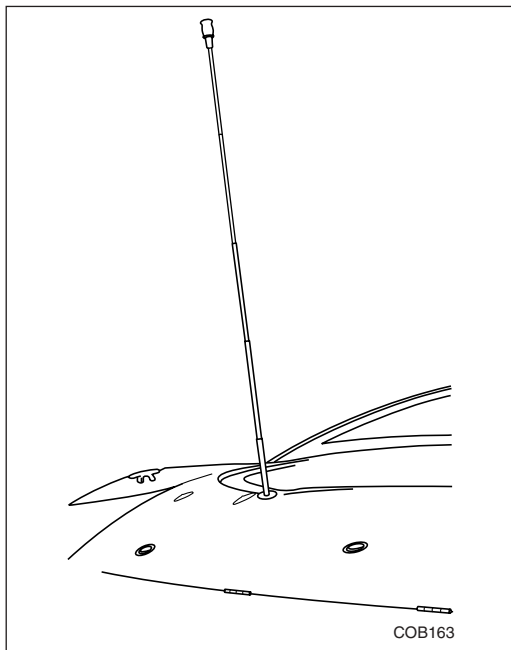

To activate, turn on the navigation light switch. The anchor light will first raise into position, then illuminate. When the light switch is turned off, the light will immediately turn off and after a 1.5 second computer check, the pole will automatically retract into its below-deck storage position. The top of the lens will be flush with the top of the deck ring. If the light does not retract automatically, do not force down, contact your Cobalt Dealer.



ANCHOR LIGHT

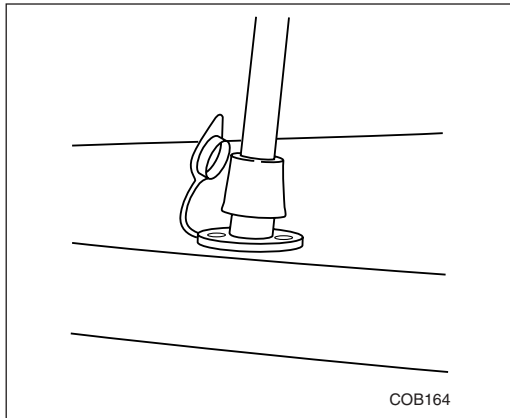

To install anchor light insert pole into socket and turn clockwise until it locks into place.

ROSEWOOD DASH (OPTIONAL) CARE

Your Rosewood veneer dash will maintain its natural beauty and high-gloss sheen when properly maintained.

- For routine cleaning wipe the wood surface with a damp soft cotton cloth. For thorough cleaning wash surface with a mild solution of soap and water, and dry with a soft cotton cloth.
- Wax or rubbing compound can be used occasionally when necessary.
- Apply liquid wax product lightly with your fingertips. Work from the center of the wood surface outward. Rub in a circular motion and stop about 1/4 inch from exterior edges of the wood. Remove wax with a clean soft cloth.
- For difficult-to-clean surfaces 3M Perfect-It III rubbing compound and a 3M “Type T” scrubbing pad can be used. Use rubbing compound carefully following manufacturer’s instructions.
- Do not use cleaners or polishes containing alcohol, ammonia, abrasives, oily emollients or petroleum-based materials.
- Avoid saturating edges of wood laminate with polish or wax. In some instances foam-backed tape used in manufacturing will absorb and retain these substances and result in premature fading and/or discoloration of your Rosewood dash. If cleaners or waxes come in contact with edges of the wood laminate, clean the surface immediately with a mild solution of soap and water.

MOTOR BOX ASSEMBLY

Manual – The motor box raises and lowers manually. Do not allow it to slam shut when closing.

Electric (Optional) – The electric motor box assembly is controlled by a switch on the dash. If you experience a battery failure, the assembly can be opened manually.



COCKPIT DINETTE TABLE - OPTIONAL

Remove the j-shaped table leg from the storage area. Slide socket cover up and insert the leg. Tighten thumbs screws on the leg for desired tightness. Slide the table top onto the leg and tighten with knob.

COCKPIT HEATER - OPTIONAL

To winterize, remove the two 5/8" cockpit heater hoses from the engine. Pump antifreeze into one hose until entire heater system is filled.

PERFECT PASS - OPTIONAL

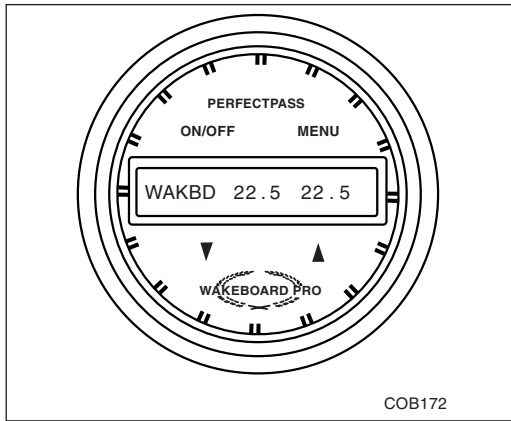

To operate the Perfect Pass speed control system set desired speed on Perfect Pass. Once your boat reaches the set speed Perfect Pass takes over and holds the speed constant. For additional operating information refer to operator's manual.

AIR COMPRESSOR - OPTIONAL

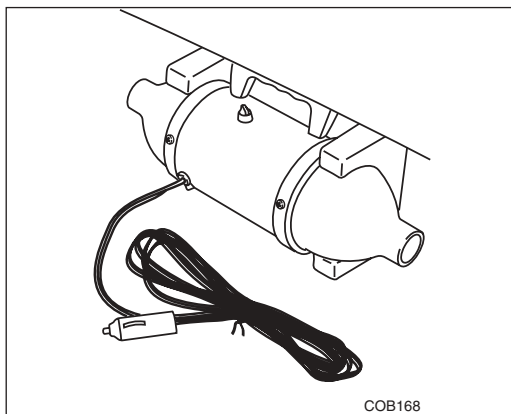

A high volume air pump is conveniently located in the starboard aft walk thru storage compartment to inflate your favorite water toys. Plug into the accessory receptacle on the dash or in the air compressor area.



FUEL ROUTING

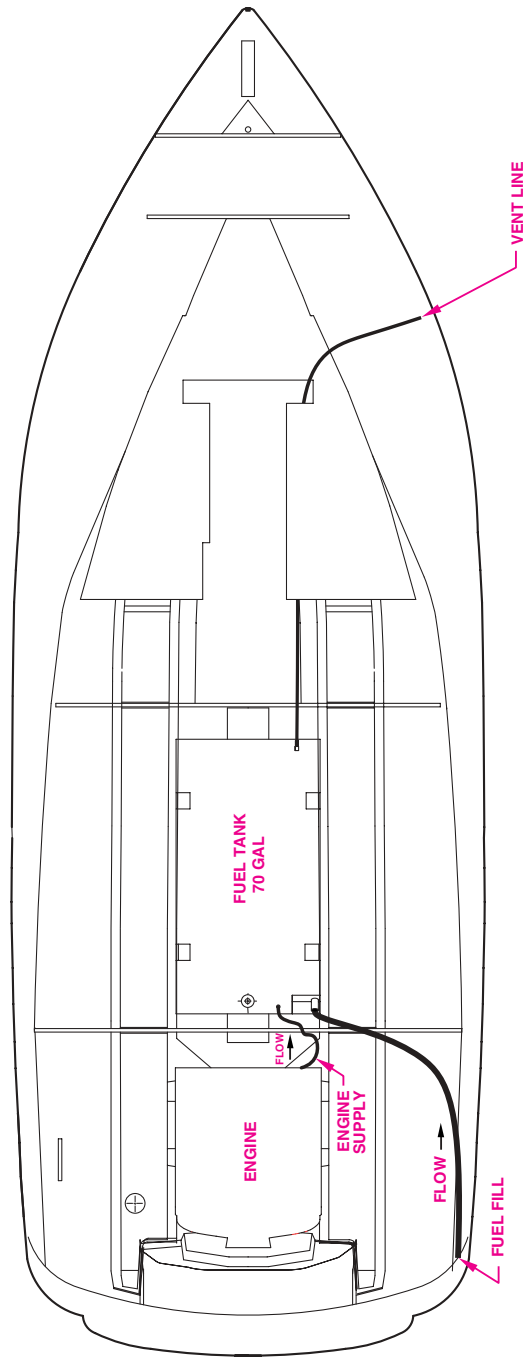

COB197



FRESH AND GRAY WATER PLUMBING

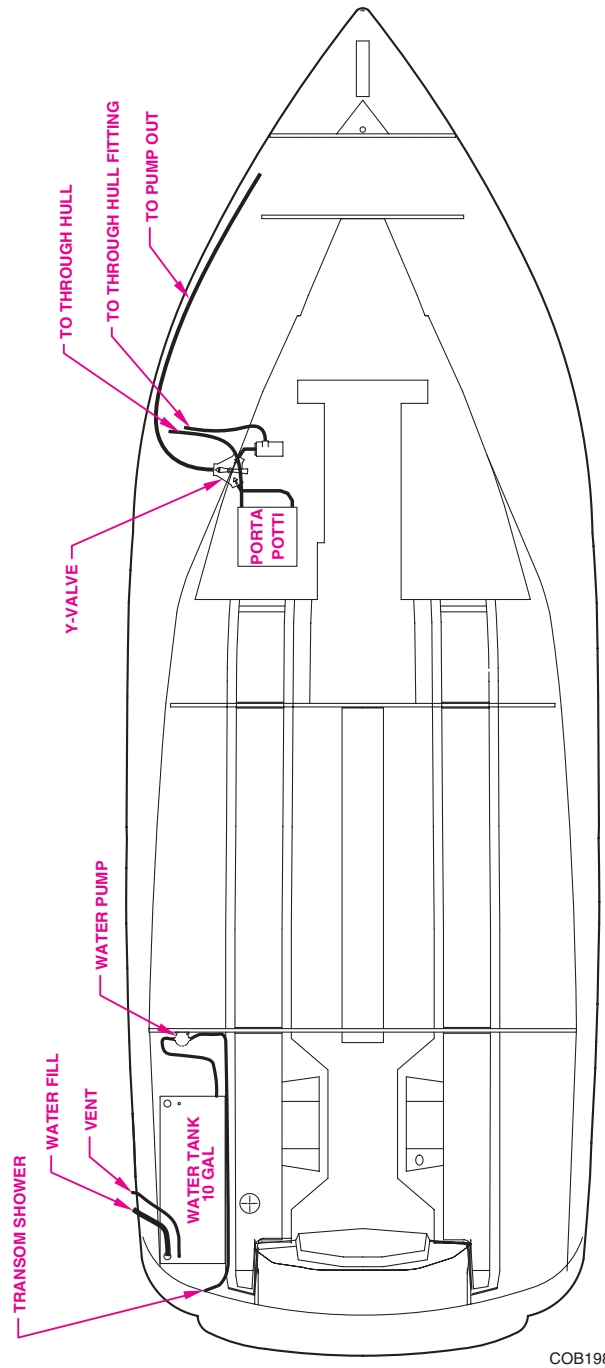



PROPELLER APPLICATION CHART

Model	Mfgr.	Engine	Drive	Fuel system	Std. Ratio	Optional Ratio	Php	Propeller Description	Mfgr. Part Number
246	MERC	4.3 L MPI	ALPHA	MPI	1.62	1.81	220		
246	MERC	4.3 L MPI	BRAVO 3	MPI	2.2	2.43	220		
246	MERC	5.0 L	ALPHA	2 BBL	1.62	1.81	220		
246	MERC	5.0 L	BRAVO 1	2 BBL	1.65	1.65	220		
246	MERC	5.0 L	BRAVO 3	2 BBL	2.2	2.43	220		
246	MERC	5.7 L	ALPHA	2 BBL	1.47	1.62	250		
246	MERC	5.7 L	BRAVO 1	2 BBL	1.65	1.65	250		
246	MERC	5.7 L	BRAVO 3	2 BBL	2.2	2.43	250		
246	MERC	5.0 L MPI	ALPHA	MPI	1.47	1.62	260		
246	MERC	5.0 L MPI	BRAVO 1	MPI	1.65	1.65	260		
246	MERC	5.0 L MPI	BRAVO 3	MPI	2.2	2.43	260		
246	MERC	350 MAG MPI	ALPHA	MPI	1.47	1.62	300		
246	MERC	350 MAG MPI	BRAVO 1	MPI	1.5	1.65	300		
246	MERC	350 MAG MPI	BRAVO 3	MPI	2.0	2.2	300	24'S B-3	48-823665A60/66A60
246	MERC	350 MAG MPI-HZN	BRAVO 3	MPI			300	24'S B-3	48-823665A60/66A60
246	MERC	6.2 MX MPI	BRAVO 1	MPI	1.65	1.65	320	19 MIR RH	48-13700A46
246	MERC	6.2 MX MPI	BRAVO 3	MPI	2.2	2.43	320	26'S B-3	48-823667A60/68A60
246	MERC	496 MAG MPI	BRAVO 1	MPI	1.50	1.65	375	23 MIR RH	48-13704A46
246	MERC	496 MAG MPI	BRAVO 3	MPI	1.81	2.2	375	26'S B-3	48-823667A60/68A60
246	MERC	496 MAG HO	BRAVO 1	MPI	1.50	1.65	425	23 MIR RH	48-13704A46
246	MERC	496 MAG HO	BRAVO 3	MPI	1.81	2.2	425	26'S B-3	48-823667A60/68A60
246	MERC	496 MAG HO-XZ	BRAVO 1	MPI			425		
246	VOLVO	5.0 GL	SX	2 BBL	1.6	1.79	220	17 AL RH	3850300
246	VOLVO	5.0 GL	DP	2 BBL	1.95	2.32	220	F5'S	3851495
246	VOLVO	5.7 GL	SX	2 BBL	1.51	1.6	260		
246	VOLVO	5.7 GL	DP	2 BBL	1.95	2.32	260		
246	VOLVO	5.0 GXi	SX	TBI	1.6	1.79	270		
246	VOLVO	5.0 GXi	DP	TBI	1.95	2.32	270	F5'S	3851495
246	VOLVO	5.7 Gi	SX	TBI	1.51	1.51	280		
246	VOLVO	5.7 Gi	DP	TBI	1.95	1.95	280	F6'S	3851496
246	VOLVO	5.7 GXi	SX	TBI	1.51	1.51	320		
246	VOLVO	5.7 GXi	DP	TBI	1.95	1.95	320	F6'S	3851496
246	VOLVO	8.1 Gi	DP	MFI	1.78	1.78	375	F8'S	3851498
246	VOLVO	8.1 GXi	DP	MFI	1.78	1.78	420	F6'S	3851496



MODEL SPECIFIC INFORMATION

COBALT BOATS - OWNER'S MANUAL

262

LAYOUT AND SPECIFICATIONS

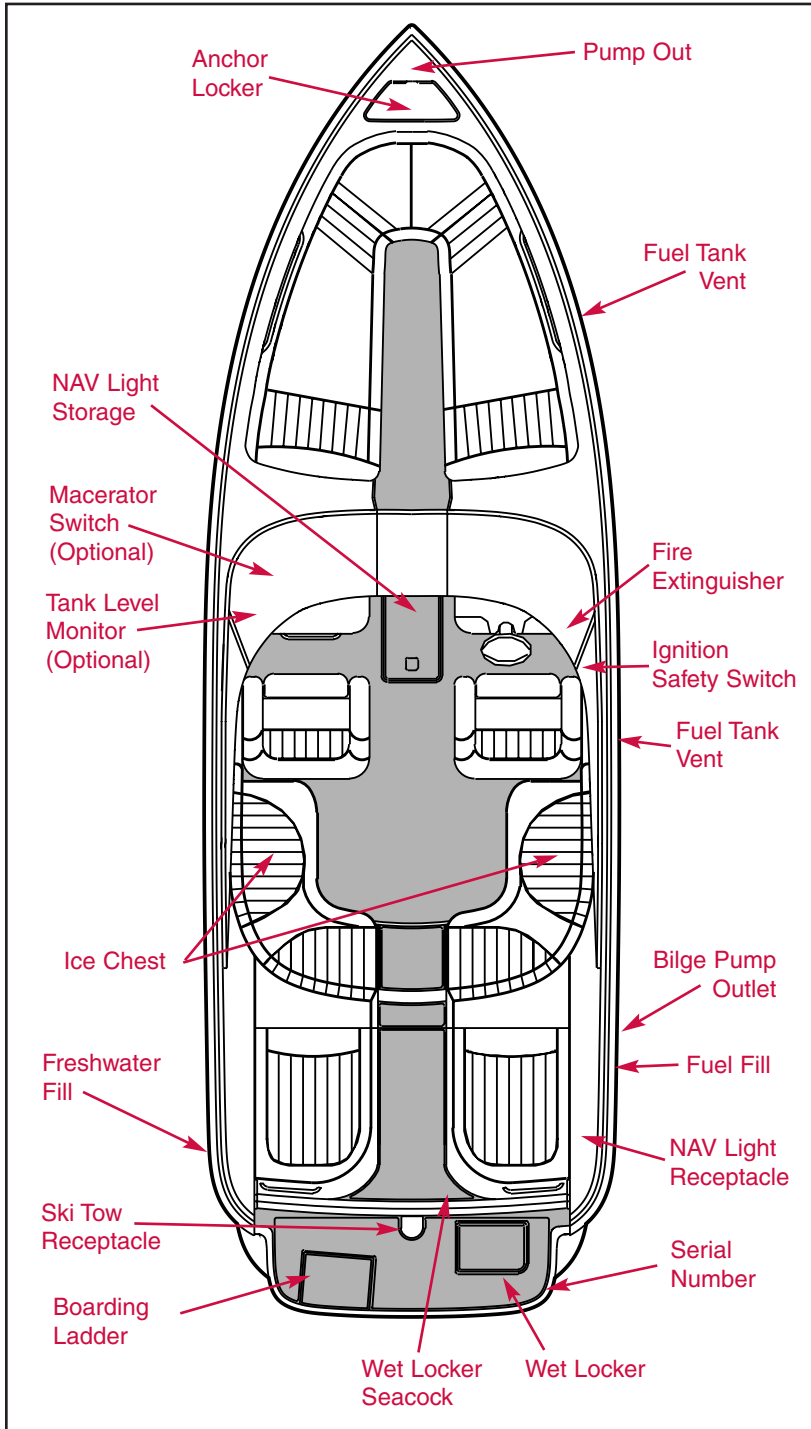

SPECIFICATIONS

Centerline 26'8"	8.13 m
Beam 8' 6"	2.59 m
Dry Weight 4700 lbs.	2131 kg
Deadrise 22 deg.	22 deg.
Fuel Capacity 70 gal.	265 L
Draft(drive up) 22"	56 cm
Draft(drive down) 39"	99 cm
Freeboard(fwd) 34"	86 cm
Freeboard(aft) 21"	53 cm
Transom Height 43"	109 cm
Bridge Clearance		
(w/o nav light) 57"	144 cm
Bridge Clearance w/Optional Bimini Arch		
(nav light down) 90"	229 cm
Freshwater Capacity	. . . 10 gal	37 L
Capacity Yacht Certified	



CAPTAIN'S CHAIR ADJUSTMENT AND OPERATION

Your captain's chairs have the flip-up position for greater visibility and maneuverability while docking. You can sit on the raised cushion or stand in front of the cushion. Standing while driving your boat should only be done while maneuvering at an idle by an experienced driver.

The starboard chair is adjustable fore and aft.

Fore and Aft adjustments - A handle under the end of the seat allows the seat to move. Make sure the mechanism is properly engaged to prevent seat movement while the boat is underway.

SWIVEL CHAIRS ADJUSTMENT AND OPERATION – OPTIONAL

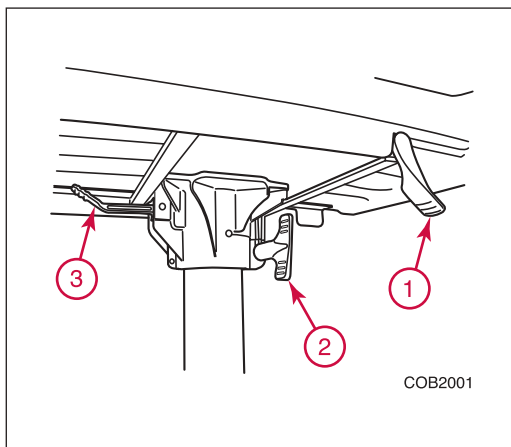

Your optional swivel chairs have the capability to rotate for convenience when moored or docked and for the passenger to spot a skier when skiing.

Both chairs rotate and are adjustable fore and aft.

1. Lift lever to adjust fore and aft.
2. Turn rotation friction handle clockwise to increase friction and counterclockwise to decrease friction. The chair should always be operated with slight friction.
3. Rotation lever for chair - move chair slightly forward, then lift lever to rotate. The lever will rest in its detent when the seat is in its forward direction.



WARNING

DRIVING WHILE STANDING UP IS AN EXTREMELY HAZARDOUS PRACTICE. DO NOT DRIVE WHILE STANDING AT SPEEDS GREATER THAN "IDLE SPEED."



CAUTION

ALL SEATS MUST BE IN A LOCKED/SECURED POSITION WHILE THE BOAT IS UNDERWAY.



INSTRUMENT PANEL

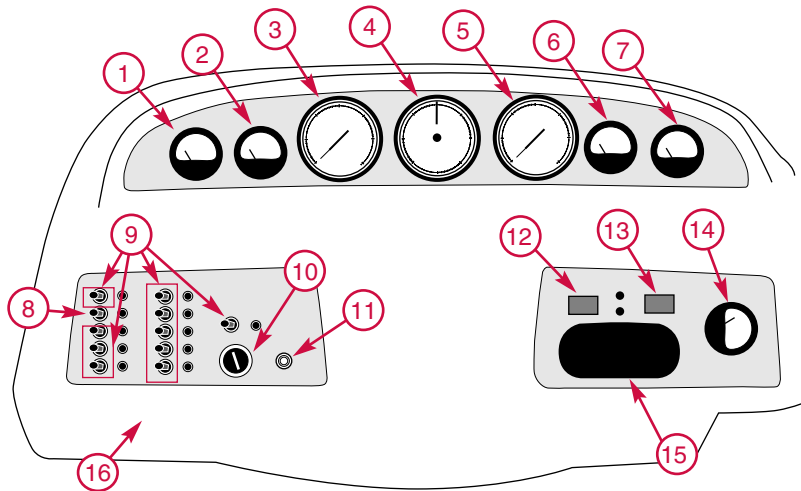

1. Fuel Gauge - shows approximate amount of fuel remaining in tank.
2. Voltmeter - shows the condition of charge in the battery. It only indicates while the ignition is in the "ON" position. With the engine at idle or not running, it may show as low as 10 to 12 volts. With the engine running at cruising speeds and above, it should show 12 to 14 volts.
3. Speedometer (Miles Per Hour)
4. Compass - Your Cobalt is equipped with a Faria Compass. The sensor is located in the ski storage locker and is adjustable. Please consult your Cobalt Dealer for further information.
5. Tachometer - (Revolutions Per Minute)
6. Temperature Gauge - Temperature may fluctuate slightly while running. Maximum temperature may vary depending on type of engine.



WARNING

SHOULD WATER TEMPERATURE REACH 180 DEGREES FAHRENHEIT, YOUR ENGINE IS OVERHEATING AND SHOULD BE CHECKED IMMEDIATELY FOR PROBABLE CAUSE.

7. Oil Pressure Gauge - Pressure can vary according to type of engine. It is normal for a hot engine to have low pressure at idle, (depending on type of oil, pressure may drop as low as 10 PSI at idle).

Please consult the engine owner's manual supplied with your boat concerning the oil pressure the engine in your boat should attain.

8. Three Position Exterior Light Switch NAV. position - navigation (running) lights, bow light and stern light. Center position - off. ANC. position - stern light only.



WARNING

NEVER OPERATE YOUR BOAT AT NIGHT WITHOUT ALL OF THE REQUIRED LIGHTS OPERATING. MAKE SURE LIGHTS ARE NOT BLOCKED BY CANVAS OR OTHER OBSTACLES.

9. Two Position Switch - Controls equipment as labeled.
10. Ignition Key Switch
11. Horn Button - The horn is located under the deck.
12. Air/Water Temperature Gauge - Moving the toggle switch below the gauge allows you to go between air and water temperature readings. The gauge will display AIR and WATER to indicate which temperature source is in use.



13. Depth Sounder - Your Cobalt is equipped with a depth sounder. To see your options - shallow, deep, keel depth and units - toggle switch to down position. To set each option to desired reading toggle switch to up position. Consult your Cobalt Dealer for further information.
14. Trim Gauge - Shows the position of the drive unit in reference to the bottom of the boat.
15. Stereo Remote Control
16. Circuit Breakers - Push to reset if necessary. The 262 breaker panel is located under the dash. If the button continues to pop out, consult your Authorized Cobalt Dealer.

TELESCOPING BOARDING LADDER

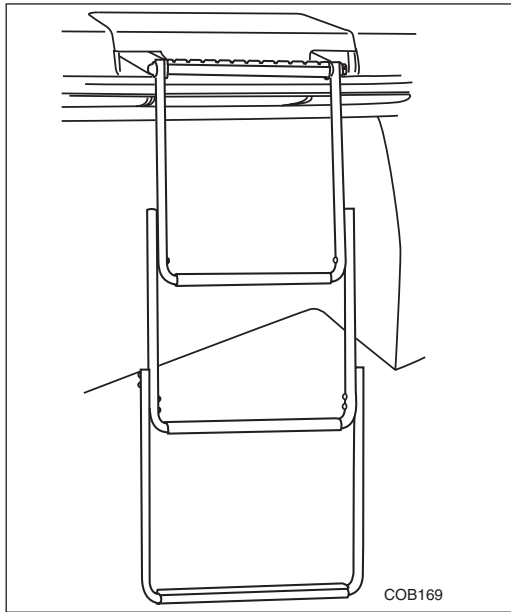

THIS LADDER MUST ONLY BE USED WHILE ENGINE IS OFF. (See warning label section). Be sure ladder is raised and secured prior to starting engine. Caution should be used while using this ladder.

Telescoping ladder is covered by ladder lid. Lift ladder lid to access ladder. Lift up on front of ladder to place overboard and telescope to full length. Use caution to prevent pinching fingers when stowing ladder.



WARNING

DO NOT USE BOARDING LADDER WHILE ENGINE IS RUNNING.



CAUTION

THE STERN DRIVE UNIT HAS MANY SHARP EDGES, ESPECIALLY THE PROPELLER. EXERCISE CAUTION WHEN NEAR THE STERN DRIVE UNIT. ALWAYS MAKE SURE THE BOARDING LADDER IS PROPERLY STOWED AND THERE IS NO ONE IN THE AREA BEHIND THE BOAT BEFORE STARTING THE ENGINE AND ENGAGING THE SHIFT MECHANISM.



HEAD COMPARTMENT

1. Make sure the head compartment door assembly is closed and latched while the boat is underway. Do not allow to swing freely.
2. For operation of the porti potti, pump out or macerator, please check the manuals supplied in your owner's packet. Refer to page 69 of this manual for more information.

SKI TOW PYLON - REMOVABLE



WARNING

SKI PYLON MUST BE REMOVED BEFORE OPENING MOTOR BOX TO PREVENT MOTOR BOX DAMAGE.



WARNING

SKI PYLON MAXIMUM LOAD 1,000 LBS.

INSTALLATION

Remove ski pylon from starboard motor box storage compartment by pulling lock button outboard and opening hold down bracket.

Insert ski pylon into base on swim platform with rope finger pointed to starboard. Push pylon down and rotate 1/4 turn clockwise to lock in place.

Press cover plate post onto pylon ring and make sure pylon is secure.

REMOVAL

Release cover plate from pylon ring; pull up and rotate pylon 1/4 turn counter-clockwise to remove.

Stow ski pylon and make sure hold down bracket is secure.

ARCH W/SUNSHADE – OPTIONAL

The Arch with Sunshade features a retractable bimini sunshade.

- To extend the sunshade, unsnap and remove the protective sunshade boot cover. By pulling on the forward cross bar, extend the sunshade forward ensuring that the port and starboard pins lock into place.
- Snap the port and starboard sunshade edges to the top of the side arms.
- Retract the sunshade and stow by reversing the above operation.



WARNING

THE ARCH WITH SUNSHADE IS DESIGNED FOR FACTORY INSTALLED EQUIPMENT ONLY. ADDITIONAL COMPONENTS CANNOT BE ADDED WITHOUT COBALT AUTHORIZATION.



ARCH MAINTENANCE

Do not “shrink wrap” or tightly bind the surface with plastic wrappings.

When tarping a boat for storage, the cover system should be ventilated to allow the coating system to “breathe.” Covers and tarps, whether synthetic or natural fiber, should not be pulled tight to painted surfaces. This condition can trap and hold moisture on the surface and may result in loss of gloss, blistering, or delamination of the topcoat.

Caution should be used to ensure that the tarp does not chafe against the surface. Such chafing, especially when accompanied by airborne dirt, can abrade the surface and cause premature loss of gloss.

Please refer to your Care and Maintenance Sheet of Awlgrip or Awlcraft supplied with your boat. For further information, consult your Cobalt Dealer.



WARNING

THE ARCH CANNOT BE USED FOR TOWING AND WILL NOT SUPPORT BODY WEIGHT.

EXTENDED SWIM PLATFORM / BOARDING LADDER – OPTIONAL

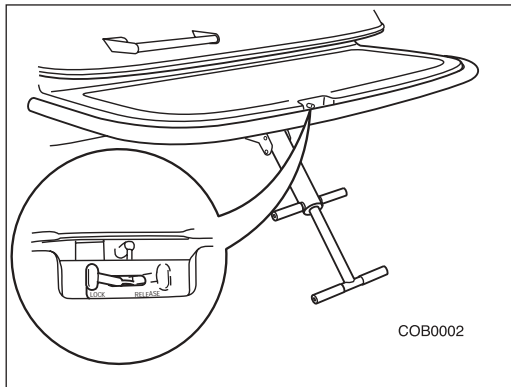

The swim platform was designed for use by people – not for the storage of personal equipment. Maximum platform weight capacity is 800 pounds. If the swim platform is removed the boat will not pass Coast Guard inspection, and the boat cannot be boarded until a boarding ladder has been installed on the swim deck. To purchase a boarding ladder consult your Cobalt Dealer.



WARNING

DO NOT OCCUPY EXTENDED SWIM PLATFORM WHILE ENGINE IS RUNNING OR ENGAGED. PROPELLER CONTACT MAY CAUSE SEVERE INJURY OR FATALITY. ALL GASOLINE POWERED ENGINES PRODUCE CARBON MONOXIDE (CO). CO IS COLORLESS, ODORLESS, AND DANGEROUS. DIRECT AND PROLONGED EXPOSURE TO CO WILL CAUSE BRAIN DAMAGE OR DEATH.

LADDER MUST ONLY BE USED WHILE THE ENGINE IS OFF. (See warning label section.) Be sure the ladder is raised and secured prior to starting engine. Exercise caution while using the ladder.

Use the release lever to release the ladder and telescope to full length. Lift ladder to retract and stow. Place release lever in the LOCK position. Use caution when stowing the ladder to prevent pinching fingers.



WARNING

DO NOT USE BOARDING LADDER WHILE ENGINE IS RUNNING.



CAUTION

THE STERN DRIVE UNIT HAS MANY SHARP EDGES, ESPECIALLY THE PROPELLER. EXERCISE CAUTION WHEN NEAR THE STERN DRIVE UNIT. ALWAYS MAKE SURE THE BOARDING LADDER IS PROPERLY STOWED AND THERE IS NO ONE IN THE AREA BEHIND THE BOAT BEFORE STARTING THE ENGINE AND ENGAGING THE SHIFT MECHANISM.

WINDSHIELD HOOK

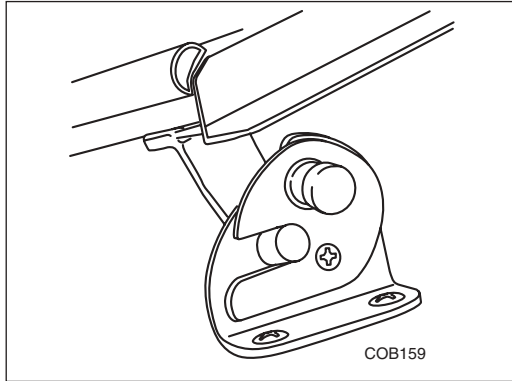

To open the windshield make sure the vertical slots in the mechanism are aligned. Swing the windshield open until the windshield post falls into the vertical slots and the mechanism locks.

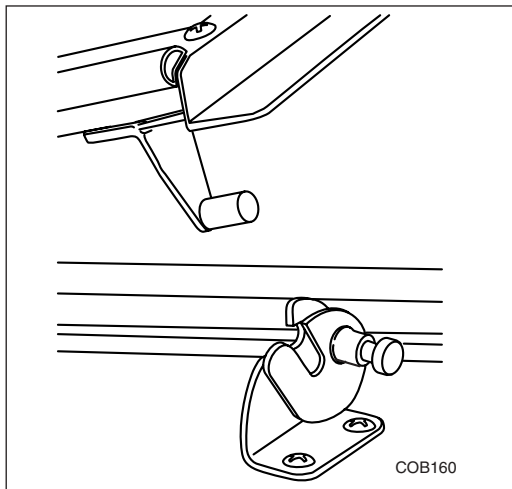

To close the windshield release the locking mechanism by pulling the forward-facing button. Swing the windshield into place.

AFT WALK-THRU FILLER CUSHIONS – OPTIONAL

Individual sun pads can be converted into a large sundeck over the motor box by installing the optional aft filler cushion. When installing the cushion, ensure the barrel bolts on the underside are secured before using.

TEMPERATURE CONTROLLED COOLER - OPTIONAL

The cooler will shut off itself when the battery is low. The cooler was designed to be used with ice to prolong the effectiveness of the cooler.



WATER SYSTEM

If your Cobalt is equipped with an optional transom shower, standard or optional galley, the system allows for a 10-gallon capacity water system. A 12VDC water pump operates the system. It is necessary for the ship's batteries to be turned ON for the water system to operate. Consult your Cobalt Dealer for winterization requirements.

To clean the water tank, the manufacturer recommends adding 1/4 cup of baking soda into the tank and allowing the tank to stand for one day, then flushing the tank twice. If this is not sufficient to clean the tank, replace the baking soda with 2 tablespoons of bleach and repeat the procedure.

SKI TOWER - OPTIONAL

The Stainless Steel Ski Tower is designed to rotate forward for storing where overhead height is an issue:

- Remove 5/16" allen head screws from both aft deck mounts. 5/16" allen head driver is provided in your boat bag.
- Loosen the forward two 5/16" allen head screws.
- Attach provided foam protectors to upper, forward cross bar of Tower.
- Carefully rotate Ski Tower forward until it rests on deck area just forward of windshield.
- Tighten forward two 5/16" Allen screws.



DANGER

SKI TOWER IS DESIGNED FOR A SINGLE SKIER ONLY.

TELESCOPING ANCHOR LIGHT

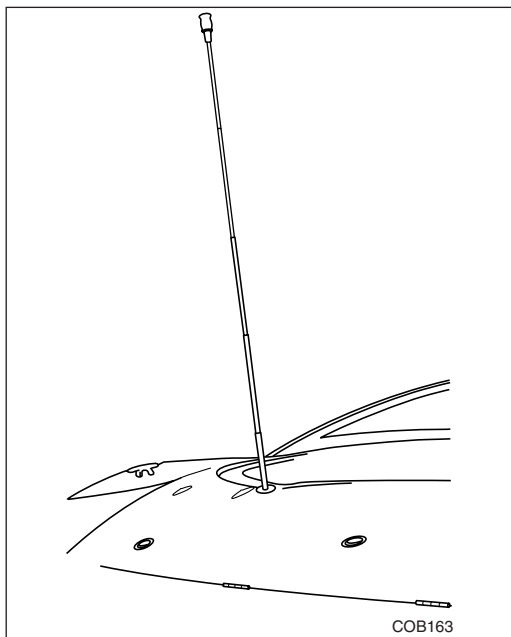

To activate, turn on the navigation light switch. The anchor light will first raise into position, then illuminate. When the light switch is turned off, the light will immediately turn off and after a 1.5 second computer check, the pole will automatically retract into its below-deck storage position. The top of the lens will be flush with the top of the deck ring. If the light does not retract automatically, do not force down, contact your Cobalt Dealer.



CARE FOR YOUR WOOD (WATERFALL BUBINGA) DASH

- Wipe the wood surface clean with a water-moistened soft cloth. For stubborn dirt and stains use a small amount of mild non-abrasive detergent (Dove, Dawn, etc.) on a moistened cloth and gently clean the area.
- Wipe surface dry with a soft non-abrasive cloth.
- Avoid flushing the wood trim with water.
- Do not use Armor All or other marine protectants.
- Apply a light coat of non-abrasive Carnauba paste to protect the surface.

CARE FOR YOUR (OPTIONAL) TEAK SWIM PLATFORM

To keep teak in top condition, clean it occasionally with a teak cleaner and reoil it at least once a season. Follow the manufacturer's instructions and warnings carefully as some cleaners and oils may damage gelcoat, vinyl, stainless or aluminum. Avoid using rust-producing steel wool pads when cleaning. Materials can be purchased from your Cobalt dealer.



NOTE

Teak sealers and cleaners can be harmful to other materials. Make sure you thoroughly remove any spills or excess. Teak should not be varnished as the natural oils in teak will cause poor adhesion.



WARNING

DO NOT STORE RAGS USED TO TREAT TEAK ON BOARD; STORE OR DISPOSE OF RAGS PROPERLY ASHORE.

MOTOR BOX ASSEMBLY

Electric – The electric motor box assembly is controlled by a switch on the dash. If you experience a battery failure, the assembly can be opened manually. Make sure the ski tow is removed before opening the motor box or damage will occur.



WARNING

RUNNING THE ENGINE WITH THE MOTOR BOX OPEN EXPOSES ROTATING MACHINERY WHICH CAN CAUSE INJURY TO THE OCCUPANTS OF THE BOAT. ALSO, WIND CONDITIONS COULD CAUSE AN OPEN MOTOR BOX TO GO BEYOND ITS DESIGN STOPS, DAMAGING THE HINGES AND FIBERGLASS.



CAUTION

DUE TO THE WEIGHT OF THIS MOTOR BOX, IT WILL REQUIRE TWO PEOPLE TO LIFT MANUALLY. TO LIFT MANUALLY, OPEN BOTH PORT AND STARBOARD AFT STORAGE LIDS AND REMOVE THE INSERT PANEL IN THE STARBOARD STORAGE AREA. POSITION ONE PERSON AT EACH GRAB HANDLE AND LIFT STRAIGHT UP. USE SAFETY SUPPORT ARM TO HOLD MOTOR BOX OPEN.



COCKPIT DINETTE TABLE - OPTIONAL

Remove the j-shaped table leg from the storage area. Slide socket cover up and insert the leg. Tighten thumbscrews on the leg for desired tightness. Slide the table top onto the leg and tighten with knob.

COCKPIT HEATER - OPTIONAL

To winterize, remove the two 5/8" cockpit heater hoses from the engine. Pump antifreeze into one hose until entire heater system is filled.

PERFECT PASS - OPTIONAL

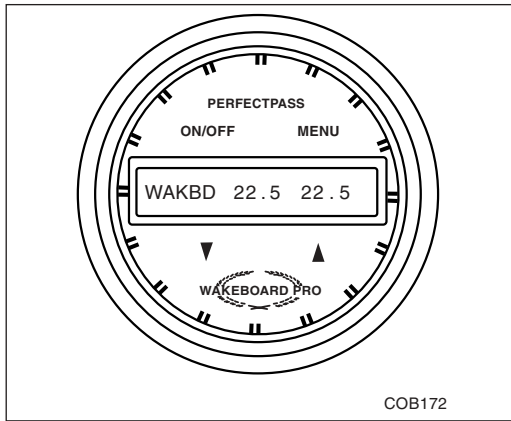

To operate the Perfect Pass speed control system set desired speed on Perfect Pass. Once your boat reaches the set speed Perfect Pass takes over and holds the speed constant. For additional operating information refer to operator's manual.

JUMP START STUD

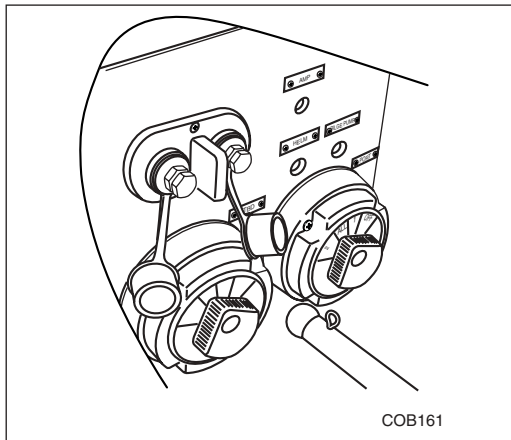

This receptacle allows for "jump starting" of the engines. The receptacles have protective covers. Be sure the covers are installed when receptacles are not being used. These can be used, when the batteries are low or removed, to raise the engine compartment.

AIR COMPRESSOR

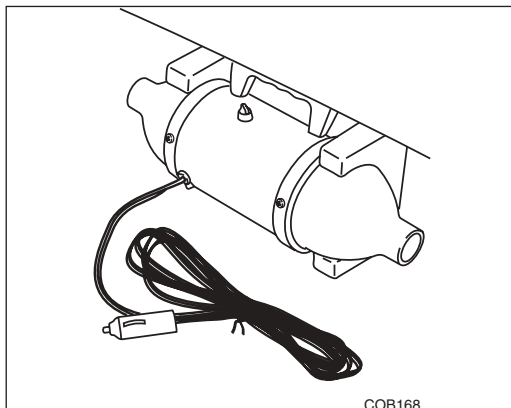

A high volume air pump is conveniently located in the aft sundeck storage compartment to inflate your favorite water toys. Plug into the accessory receptacle on the dash or in the air compressor area.



ELECTRICAL WIRING HARNESS

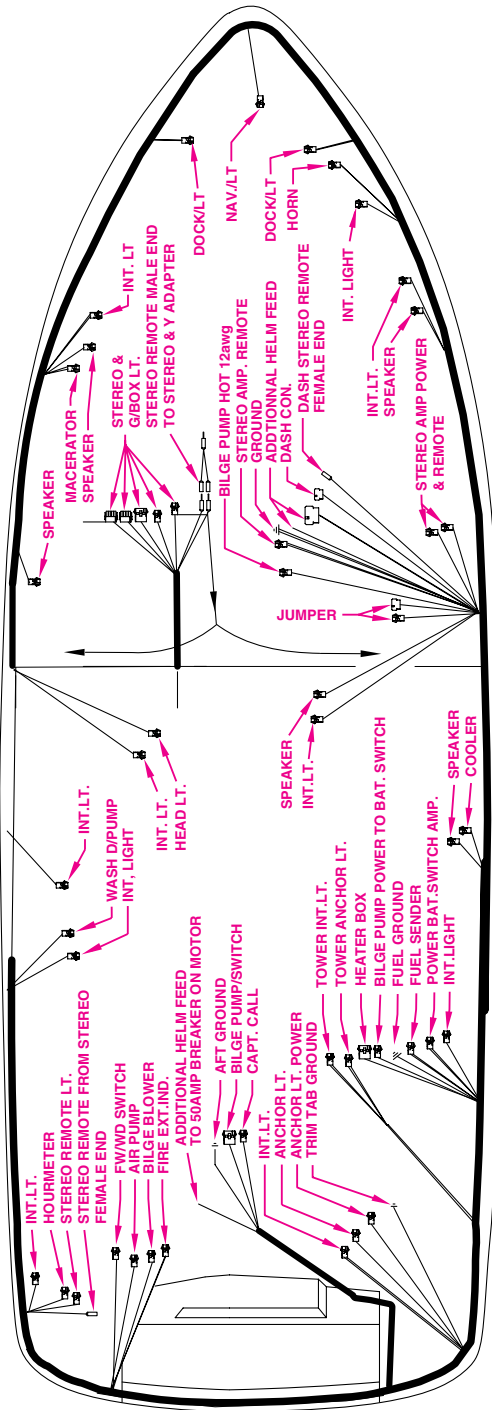

COB199



FUEL ROUTING

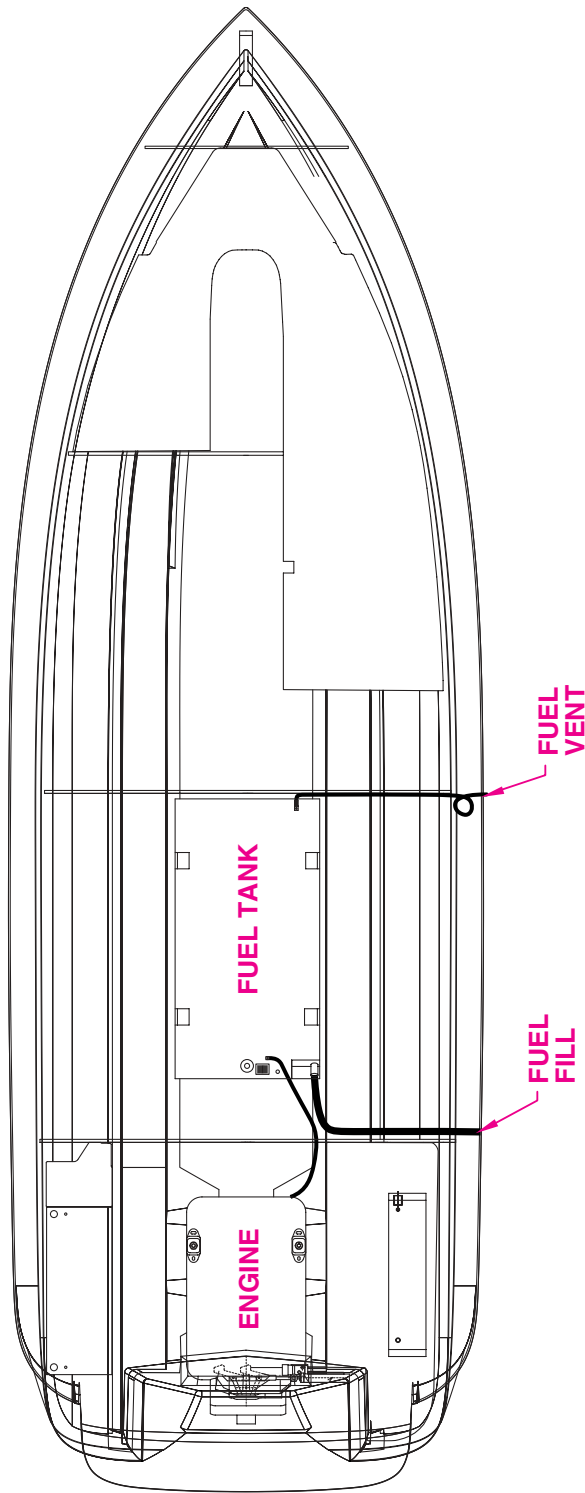

COB200



FRESH WATER PLUMBING

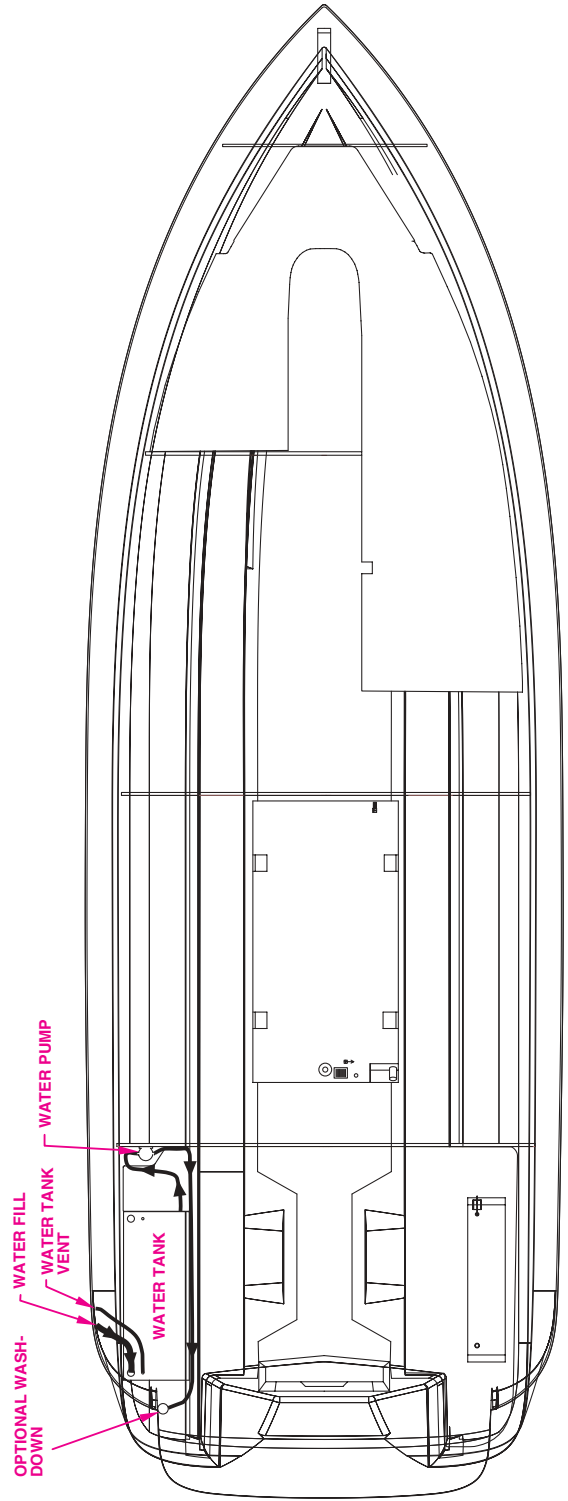



GRAY WATER PLUMBING

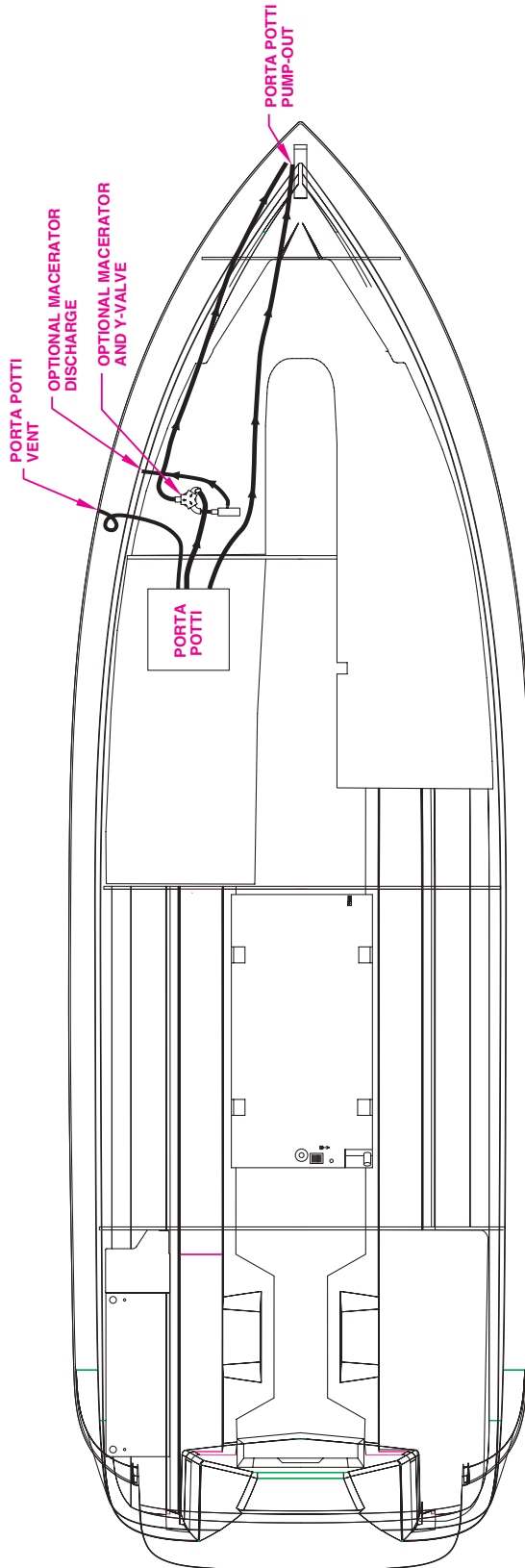

COB202



PROPELLER APPLICATION CHART

Model	Mfgr.	Engine	Drive	Fuel system	Std. Ratio	Optional Ratio	Php	Propeller Description	Mfgr. Part Number
262	MERC	5.7 L	ALPHA	2 BBL	1.47	1.62	250		
262	MERC	5.7 L	BRAVO 1	2 BBL	1.65	1.65	250		
262	MERC	5.7 L	BRAVO 3	2 BBL	2.2	2.43	250		
262	MERC	5.0 L MPI	ALPHA	MPI	1.47	1.62	260		
262	MERC	5.0 L MPI	BRAVO 1	MPI	1.65	1.65	260		
262	MERC	5.0 L MPI	BRAVO 3	MPI	2.2	2.43	260		
262	MERC	350 MAG MPI	ALPHA	MPI	1.47	1.62	300		
262	MERC	350 MAG MPI	BRAVO 1	MPI	1.5	1.65	300		
262	MERC	350 MAG MPI	BRAVO 3	MPI	2.0	2.2	300	24'S B-3	48-823665A60/66A60
262	MERC	350 MAG MPI-HZN	BRAVO 3	MPI			300	24'S B-3	48-823665A60/66A60
262	MERC	6.2 MX MPI	BRAVO 1	MPI	1.65	1.65	320		
262	MERC	6.2 MX MPI	BRAVO 3	MPI	2.2	2.43	320	26'S B-3	48-823667A60/68A60
262	MERC	496 MAG MPI	BRAVO 1	MPI	1.50	1.65	375	23 MIR RH	48-13704A46
262	MERC	496 MAG MPI	BRAVO 3	MPI	1.81	2.2	375	24'S B-3	48-823665A60/66A60
262	MERC	496 MAG HO	BRAVO 1	MPI	1.50	1.65	425	23 MIR RH	48-13704A46
262	MERC	496 MAG HO	BRAVO 3	MPI	1.81	2.2	425	24'S B-3	48-823665A60/66A60
262	MERC	496 MAG HO-XZ	BRAVO 1	MPI			425		
262	VOLVO	5.7 GL	SX	2 BBL	1.51	1.6	260		
262	VOLVO	5.7 GL	DP	2 BBL	1.95	2.32	260		
262	VOLVO	5.0 GXi	SX	TBI	1.6	1.79	270		
262	VOLVO	5.0 GXi	DP	TBI	1.95	2.32	270		
262	VOLVO	5.7 Gi	SX	TBI	1.51	1.51	280		
262	VOLVO	5.7 Gi	DP	TBI	1.95	1.95	280	F5'S	3851495
262	VOLVO	5.7 GXi	SX	TBI	1.51	1.51	320		
262	VOLVO	5.7 GXi	DP	TBI	1.95	1.95	320	F5'S	3851495
262	VOLVO	8.1 Gi	DP	MFI	1.78	1.78	375	F7'S	3851497
262	VOLVO	8.1 GXi	DP	MFI	1.78	1.78	420	F7'S	3851497





MODEL SPECIFIC INFORMATION

COBALT BOATS - OWNER'S MANUAL

263

LAYOUT AND SPECIFICATIONS

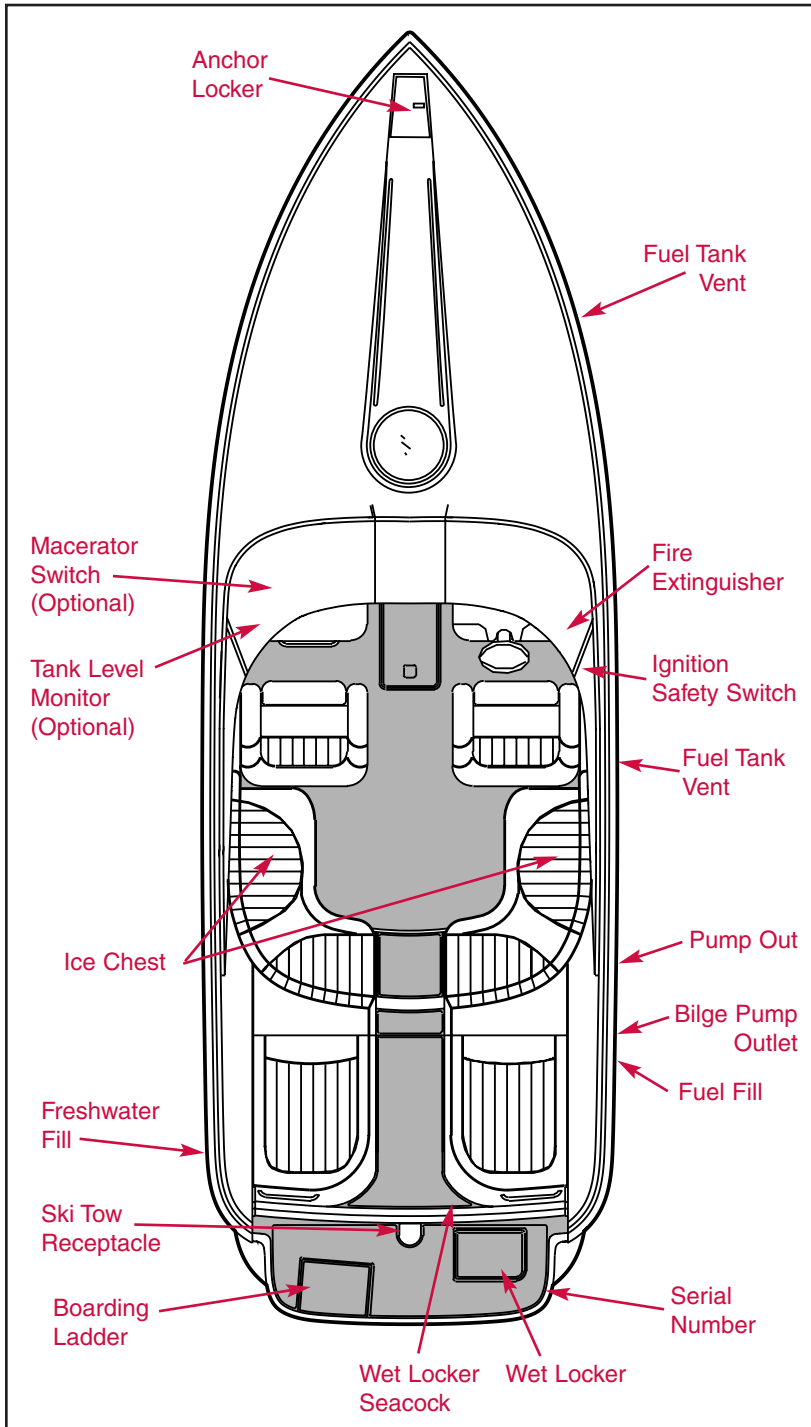

SPECIFICATIONS

Centerline 26'8"	8.13 m
Beam 8' 6"	2.59 m
Dry Weight 4700 lbs.	2131 kg
Deadrise 22 deg.	22 deg.
Fuel Capacity 70 gal.	265 L
Draft(drive up) 22"	56 cm
Draft(drive down) 39"	99 cm
Freeboard(fwd) 34"	86 cm
Freeboard(aft) 21"	53 cm
Transom Height 43"	109 cm
Bridge Clearance		
(w/o nav light) 57"	144 cm
Bridge Clearance w/Optional Bimini Arch		
(nav light down) 90"	229 cm
Freshwater Capacity	. . . 10 gal	37 L
Capacity Yacht Certified	



CAPTAIN'S CHAIR ADJUSTMENT AND OPERATION

Your captain's chairs have the flip-up position for greater visibility and maneuverability while docking. You can sit on the raised cushion or stand in front of the cushion. Standing while driving your boat should only be done while maneuvering at an idle by an experienced driver.

The stbd. chair is adjustable fore and aft.

Fore and Aft adjustments - A handle under the end of the seat allows the seat to move. Make sure the mechanism is properly engaged to prevent seat movement while the boat is underway.

SWIVEL CHAIRS ADJUSTMENT AND OPERATION – OPTIONAL

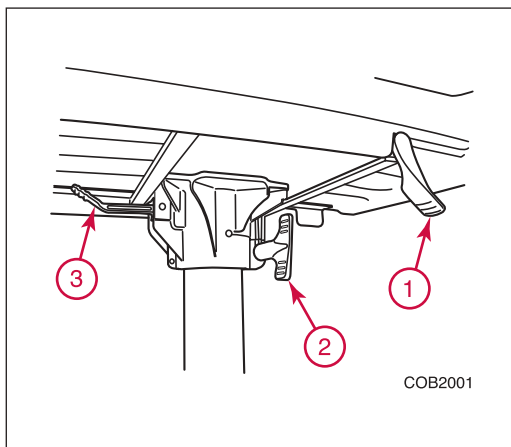

Your optional swivel chairs have the capability to rotate for convenience when moored or docked and for the passenger to spot a skier when skiing.

Both chairs rotate and are adjustable fore and aft.

1. Lift lever to adjust fore and aft.
2. Turn rotation friction handle clockwise to increase friction and counterclockwise to decrease friction. The chair should always be operated with slight friction.
3. Rotation lever for chair - move chair slightly forward, then lift lever to rotate. The lever will rest in its detent when the seat is in its forward direction.



WARNING

DRIVING WHILE STANDING UP IS AN EXTREMELY HAZARDOUS PRACTICE. DO NOT DRIVE WHILE STANDING AT SPEEDS GREATER THAN "IDLE SPEED."



CAUTION

ALL SEATS MUST BE IN A LOCKED/SECURED POSITION WHILE THE BOAT IS UNDERWAY.



INSTRUMENT PANEL

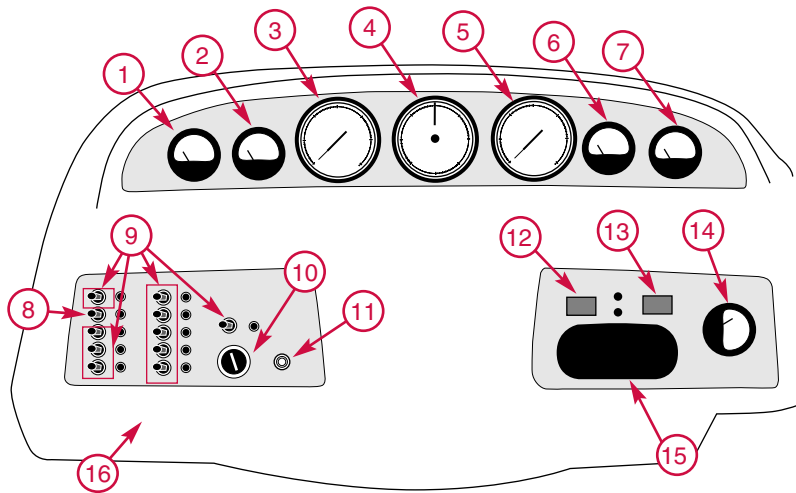

1. Fuel Gauge - shows approximate amount of fuel remaining in tank.
2. Voltmeter - shows the condition of charge in the battery. It only indicates while the ignition is in the "ON" position. With the engine at idle or not running, it may show as low as 10 to 12 volts. With the engine running at cruising speeds and above, it should show 12 to 14 volts.
3. Speedometer (Miles Per Hour)
4. Compass - Your Cobalt is equipped with a Faria Compass. The sensor is located in the ski storage locker and is adjustable. Please consult your Cobalt Dealer for further information.
5. Tachometer - (Revolutions Per Minute)
6. Temperature Gauge - Temperature may fluctuate slightly while running. Maximum temperature may vary depending on type of engine.



WARNING

SHOULD WATER TEMPERATURE REACH 180 DEGREES FAHRENHEIT, YOUR ENGINE IS OVERHEATING AND SHOULD BE CHECKED IMMEDIATELY FOR PROBABLE CAUSE.

7. Oil Pressure Gauge - Pressure can vary according to type of engine. It is normal for a hot engine to have low pressure at idle, (depending on type of oil, pressure may drop as low as 10 PSI at idle).

Please consult the engine owner's manual supplied with your boat concerning the oil pressure the engine in your boat should attain.

8. Three Position Exterior Light Switch NAV. position - navigation (running) lights, bow light and stern light. Center position - off. ANC. position - stern light only.



WARNING

NEVER OPERATE YOUR BOAT AT NIGHT WITHOUT ALL OF THE REQUIRED LIGHTS OPERATING. MAKE SURE LIGHTS ARE NOT BLOCKED BY CANVAS OR OTHER OBSTACLES.

9. Two Position Switch - Controls equipment as labeled.
10. Ignition Key Switch
11. Horn Button - The horn is located under the deck.
12. Air/Water Temperature Gauge - Moving the toggle switch below the gauge allows you to go between air and water temperature readings. The gauge will display AIR and WATER to indicate which temperature source is in use.



13. Depth Sounder - Your Cobalt is equipped with a depth sounder. To see your options - shallow, deep, keel depth and units - toggle switch to down position. To set each option to desired reading toggle switch to up position. Consult your Cobalt Dealer for further information.
14. Trim Gauge - Shows the position of the drive unit in reference to the bottom of the boat.
15. Stereo Remote Control
16. Circuit Breakers - Push to reset if necessary. The 262 breaker panel is located under the dash. If the button continues to pop out, consult your Authorized Cobalt Dealer.

TELESCOPING BOARDING LADDER

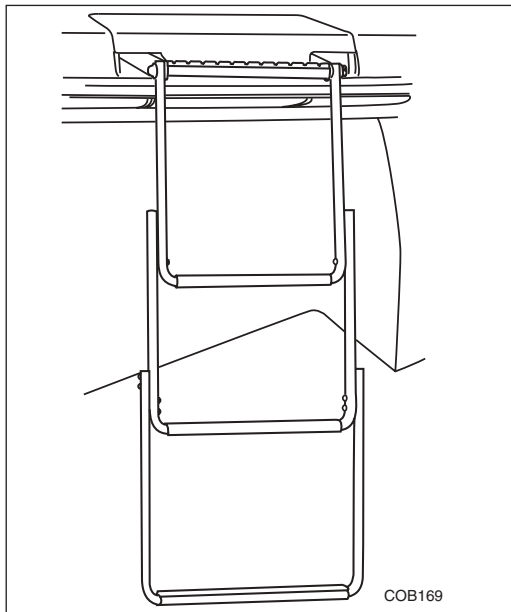

THIS LADDER MUST ONLY BE USED WHILE ENGINE IS OFF. (See warning label section). Be sure ladder is raised and secured prior to starting engine. Caution should be used while using this ladder.

Telescoping ladder is covered by ladder lid. Lift ladder lid to access ladder. Lift up on front of ladder to place overboard and telescope to full length. Use caution to prevent pinching fingers when stowing ladder.



WARNING

DO NOT USE BOARDING LADDER WHILE ENGINE IS RUNNING.



CAUTION

THE STERN DRIVE UNIT HAS MANY SHARP EDGES, ESPECIALLY THE PROPELLER. EXERCISE CAUTION WHEN NEAR THE STERN DRIVE UNIT. ALWAYS MAKE SURE THE BOARDING LADDER IS PROPERLY STOWED AND THERE IS NO ONE IN THE AREA BEHIND THE BOAT BEFORE STARTING THE ENGINE AND ENGAGING THE SHIFT MECHANISM.



SKI TOW PYLON - REMOVABLE



WARNING

SKI PYLON MUST BE REMOVED BEFORE OPENING MOTOR BOX TO PREVENT MOTOR BOX DAMAGE.



WARNING

SKI PYLON MAXIMUM LOAD 1,000 LBS.

INSTALLATION

Remove ski pylon from starboard motor box storage compartment by pulling lock button outboard and opening hold down bracket.

Insert ski pylon into base on swim platform with rope finger pointed to starboard. Push pylon down and rotate 1/4 turn clockwise to lock in place.

Press cover plate post onto pylon ring and make sure pylon is secure.

REMOVAL

Release cover plate from pylon ring; pull up and rotate pylon 1/4 turn counter-clockwise to remove.

Stow ski pylon and make sure hold down bracket is secure.

ARCH W/SUNSHADE – OPTIONAL

The Arch with Sunshade features a retractable bimini sunshade.

- To extend the sunshade, unsnap and remove the protective sunshade boot cover. By pulling on the forward cross bar, extend the sunshade forward ensuring that the port and starboard pins lock into place.
- Snap the port and starboard sunshade edges to the top of the side arms.
- Retract the sunshade and stow by reversing the above operation.



WARNING

THE ARCH WITH SUNSHADE IS DESIGNED FOR FACTORY INSTALLED EQUIPMENT ONLY. ADDITIONAL COMPONENTS CANNOT BE ADDED WITHOUT COBALT AUTHORIZATION.

ARCH MAINTENANCE

Do not “shrink wrap” or tightly bind the surface with plastic wrappings.

When tarping a boat for storage, the cover system should be ventilated to allow the coating system to “breathe.” Covers and tarps, whether synthetic or natural fiber, should not be pulled tight to painted surfaces. This condition can trap and hold moisture on the surface and may result in loss of gloss, blistering, or delamination of the topcoat.

Caution should be used to ensure that the tarp does not chafe against the surface. Such chafing, especially when accompanied by airborne dirt, can abrade the surface and cause premature loss of gloss.



Please refer to your Care and Maintenance Sheet of Awlgrip or Awlcraft supplied with your boat. For further information, consult your Cobalt Dealer.



WARNING

THE ARCH CANNOT BE USED FOR TOWING AND WILL NOT SUPPORT BODY WEIGHT.

DECK HATCH

The deck hatch is manually operable. To open, simply release the one or two hasps on the edge of the hatch, make sure the support bracket adjusters are loose, and raise the hatch to the desired position and secure the adjusters.



CAUTION

DO NOT USE A RAISED HATCH FOR A SUPPORT OR HAND HOLD WHILE ON THE DECK. BE SURE HATCH IS FIRMLY SECURED WHILE UNDERWAY.

CUDDY CABIN ACCESS DOOR

The sliding door assembly can be in the open or closed position while running. Make sure the door is secured in either the open or closed position. Do not allow to slide free.

V-BERTH FILLER CUSHION

The cabin is converted into sleeping accommodations for two by installing the V-berth Filler Cushion. To utilize, install three support braces (located in hanging locker) into the existing brackets. Once these supports are installed, install table on support braces. The cushion will set flush with the standard V-berth cushions.

EXTENDED SWIM PLATFORM – OPTIONAL

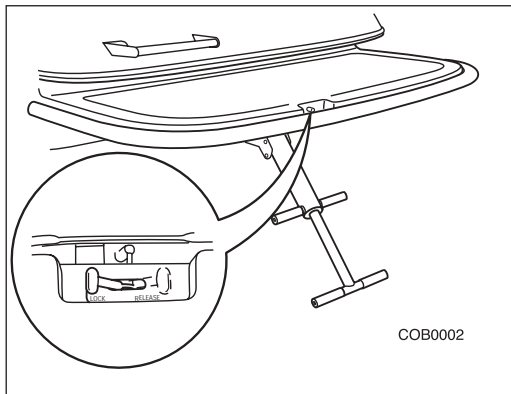

The swim platform was designed for use by people – not for the storage of personal equipment. Maximum platform weight capacity is 800 pounds. If the swim platform is removed the boat will not pass Coast Guard inspection, and the boat cannot be boarded until a boarding ladder has been installed on the swim deck. To purchase a boarding ladder consult your Cobalt Dealer.



WARNING

DO NOT OCCUPY EXTENDED SWIM PLATFORM WHILE ENGINE IS RUNNING OR ENGAGED. PROPELLER CONTACT MAY CAUSE SEVERE INJURY OR FATALITY. ALL GASOLINE POWERED ENGINES PRODUCE CARBON MONOXIDE (CO). CO IS COLORLESS, ODORLESS, AND DANGEROUS. DIRECT AND PROLONGED EXPOSURE TO CO WILL CAUSE BRAIN DAMAGE OR DEATH.



LADDER MUST ONLY BE USED WHILE THE ENGINE IS OFF. (See warning label section.) Be sure the ladder is raised and secured prior to starting engine. Exercise caution while using the ladder.

Use the release lever to release the ladder and telescope to full length. Lift ladder to retract and stow. Place release lever in the LOCK position. Use caution when stowing the ladder to prevent pinching fingers.



WARNING

DO NOT USE BOARDING LADDER WHILE ENGINE IS RUNNING.



CAUTION

THE STERN DRIVE UNIT HAS MANY SHARP EDGES, ESPECIALLY THE PROPELLER. EXERCISE CAUTION WHEN NEAR THE STERN DRIVE UNIT. ALWAYS MAKE SURE THE BOARDING LADDER IS PROPERLY STOWED AND THERE IS NO ONE IN THE AREA BEHIND THE BOAT BEFORE STARTING THE ENGINE AND ENGAGING THE SHIFT MECHANISM.

WINDSHIELD HOOK

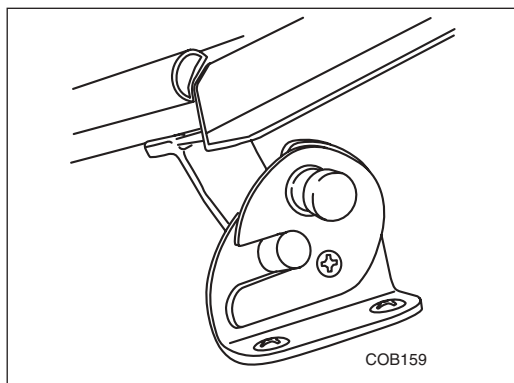

To open the windshield make sure the vertical slots in the mechanism are aligned. Swing the windshield open until the windshield post falls into the vertical slots and the mechanism locks.

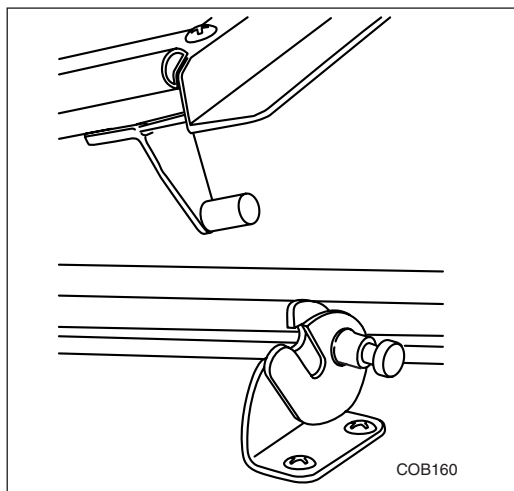

To close the windshield release the locking mechanism by pulling the forward-facing button. Swing the windshield into place.

HEAD

For operation of the porti potti, pump out or macerator, please check the manuals supplied in your owner's packet. Refer to page 69 of this manual for more information.



AFT WALK-THRU FILLER CUSHIONS – OPTIONAL

Individual sun pads can be converted into a large sundeck over the motor box by installing the optional aft filler cushion. When installing the cushion, ensure the barrel bolts on the underside are secured before using.

TEMPERATURE CONTROLLED COOLER - OPTIONAL

The cooler will shut off itself when the battery is low. The cooler was designed to be used with ice to prolong the effectiveness of the cooler.

WATER SYSTEM

If your Cobalt is equipped with an optional transom shower, standard or optional galley, the system allows for a 10-gallon capacity water system. A 12VDC water pump operates the system. It is necessary for the ship's batteries to be turned ON for the water system to operate. Consult your Cobalt Dealer for winterization requirements.

To clean the water tank, the manufacturer recommends adding 1/4 cup of baking soda into the tank and allowing the tank to stand for one day, then flushing the tank twice. If this is not sufficient to clean the tank, replace the baking soda with 2 tablespoons of bleach and repeat the procedure.

SKI TOWER - OPTIONAL

The Stainless Steel Ski Tower is designed to rotate forward for storing where overhead height is an issue:

- Remove 5/16" allen head screws from both aft deck mounts. 5/16" allen head driver is provided in your boat bag.
- Loosen the forward two 5/16" allen head screws.
- Attach provided foam protectors to upper, forward cross bar of Tower.
- Carefully rotate Ski Tower forward until it rests on deck area just forward of windshield.
- Tighten forward two 5/16" Allen screws.



SKI TOWER IS DESIGNED FOR A SINGLE SKIER ONLY.



TELESCOPING ANCHOR LIGHT

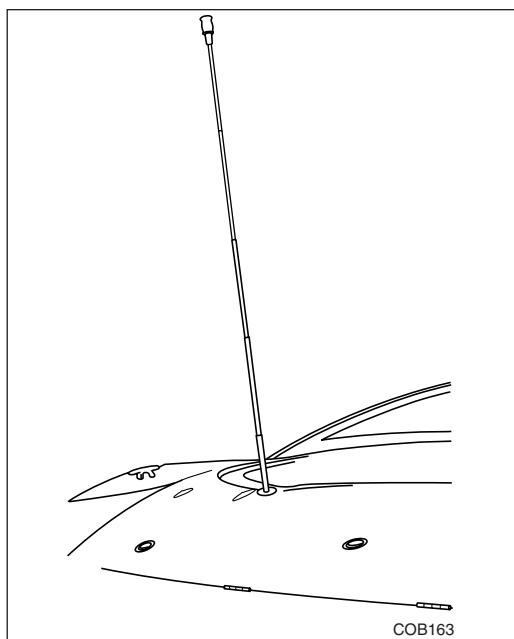

To activate, turn on the navigation light switch. The anchor light will first raise into position, then illuminate. When the light switch is turned off, the light will immediately turn off and after a 1.5 second computer check, the pole will automatically retract into its below-deck storage position. The top of the lens will be flush with the top of the deck ring. If the light does not retract automatically, do not force down, contact your Cobalt Dealer.

CARE FOR YOUR WOOD (WATERFALL BUBINGA) DASH

- Wipe the wood surface clean with a water-moistened soft cloth. For stubborn dirt and stains use a small amount of mild non-abrasive detergent (Dove, Dawn, etc.) on a moistened cloth and gently clean the area.
- Wipe surface dry with a soft non-abrasive cloth.
- Avoid flushing the wood trim with water.
- Do not use Armor All or other marine protectants.
- Apply a light coat of non-abrasive Carnauba paste to protect the surface.

CARE FOR YOUR (OPTIONAL) TEAK SWIM PLATFORM

To keep teak in top condition, clean it occasionally with a teak cleaner and reoil it at least once a season. Follow the manufacturer's instructions and warnings carefully as some cleaners and oils may damage gelcoat, vinyl, stainless or aluminum. Avoid using rust-producing steel wool pads when cleaning. Materials can be purchased from your Cobalt dealer.



NOTE

Teak sealers and cleaners can be harmful to other materials. Make sure you thoroughly remove any spills or excess. Teak should not be varnished as the natural oils in teak will cause poor adhesion.



WARNING

DO NOT STORE RAGS USED TO TREAT TEAK ON BOARD; STORE OR DISPOSE OF RAGS PROPERLY ASHORE.



MOTOR BOX ASSEMBLY

Electric – The electric motor box assembly is controlled by a switch on the dash. If you experience a battery failure, the assembly can be opened manually. Make sure the ski tow is removed before opening the motor box or damage will occur.



WARNING

RUNNING THE ENGINE WITH THE MOTOR BOX OPEN EXPOSES ROTATING MACHINERY WHICH CAN CAUSE INJURY TO THE OCCUPANTS OF THE BOAT. ALSO, WIND CONDITIONS COULD CAUSE AN OPEN MOTOR BOX TO GO BEYOND ITS DESIGN STOPS, DAMAGING THE HINGES AND FIBERGLASS.



CAUTION

DUE TO THE WEIGHT OF THIS MOTOR BOX, IT WILL REQUIRE TWO PEOPLE TO LIFT MANUALLY. TO LIFT MANUALLY, OPEN BOTH PORT AND STARBOARD AFT STORAGE LIDS AND REMOVE THE INSERT PANEL IN THE STARBOARD STORAGE AREA. POSITION ONE PERSON AT EACH GRAB HANDLE AND LIFT STRAIGHT UP. USE SAFETY SUPPORT ARM TO HOLD MOTOR BOX OPEN.

COCKPIT DINETTE TABLE - OPTIONAL

Remove the j-shaped table leg from the storage area. Slide socket cover up and insert the leg. Tighten thumbs screws on the leg for desired tightness. Slide the table top onto the leg and tighten with knob.

COCKPIT HEATER - OPTIONAL

To winterize, remove the two 5/8" cockpit heater hoses from the engine. Pump antifreeze into one hose until entire heater system is filled.

PERFECT PASS - OPTIONAL

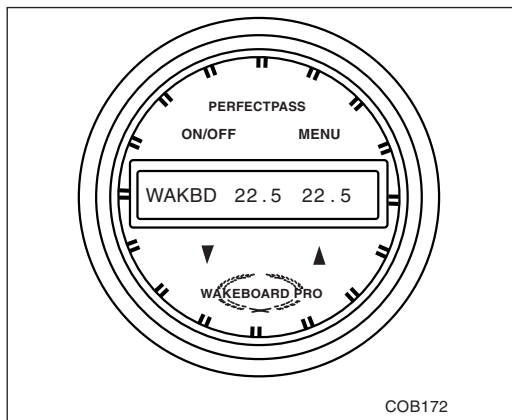

To operate the Perfect Pass speed control system set desired speed on Perfect Pass. Once your boat reaches the set speed Perfect Pass takes over and holds the speed constant. For additional operating information refer to operator's manual.



JUMP START STUD

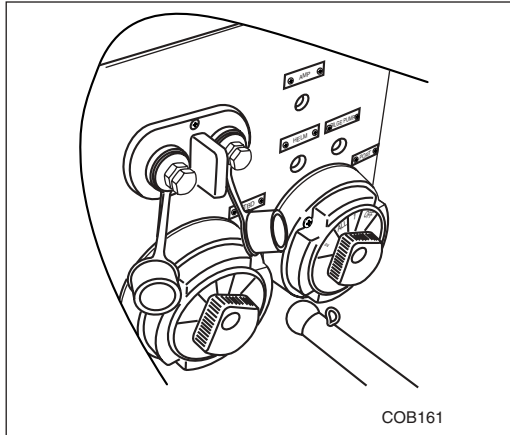

This receptacle allows for “jump starting” of the engines. The receptacles have protective covers. Be sure the covers are installed when receptacles are not being used. These can be used, when the batteries are low or removed, to raise the engine compartment.

AIR COMPRESSOR

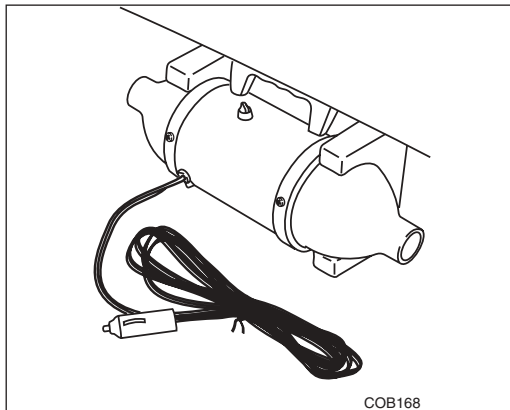

A high volume air pump is conveniently located in the aft sundeck storage compartment to inflate your favorite water toys. Plug into the accessory receptacle on the dash or in the air compressor area.



ELECTRICAL WIRING HARNESS

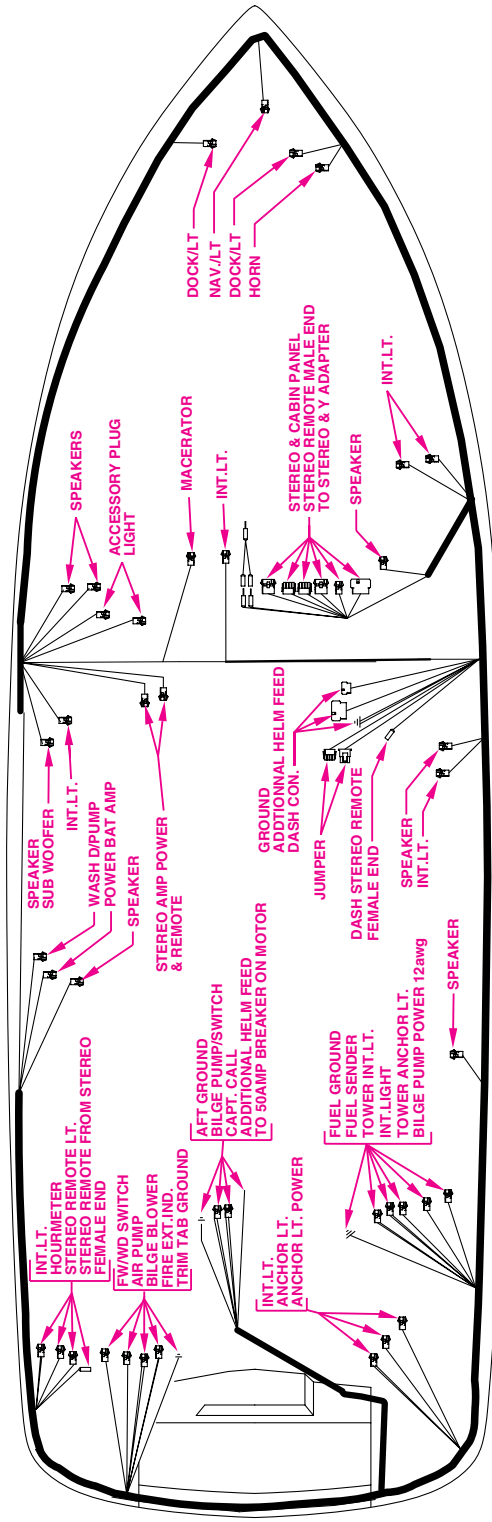

COB203



FUEL ROUTING

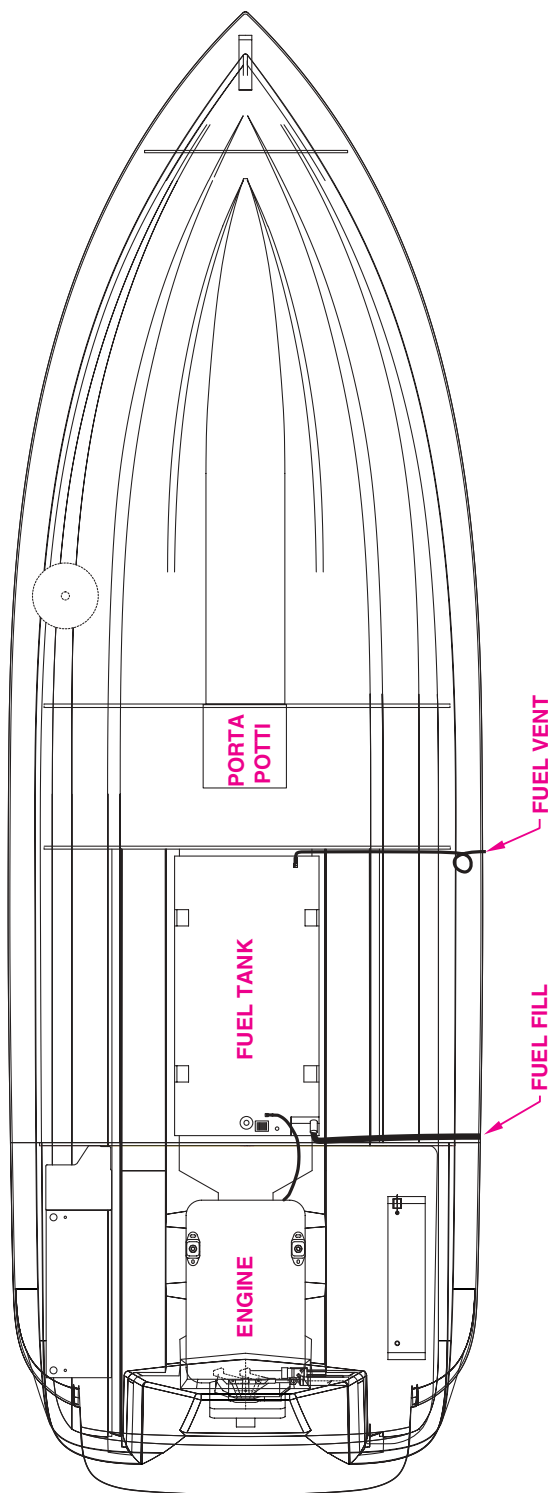

COB204



FRESH WATER PLUMBING

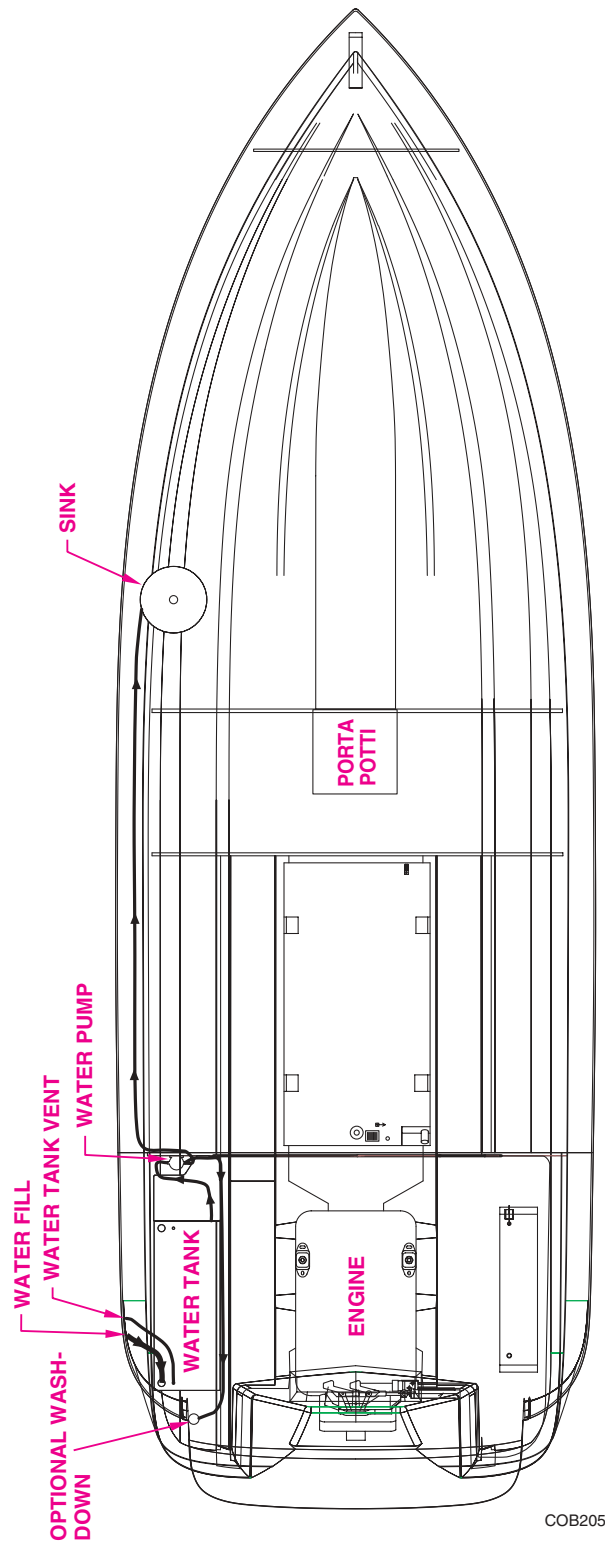

COB205



GRAY WATER PLUMBING

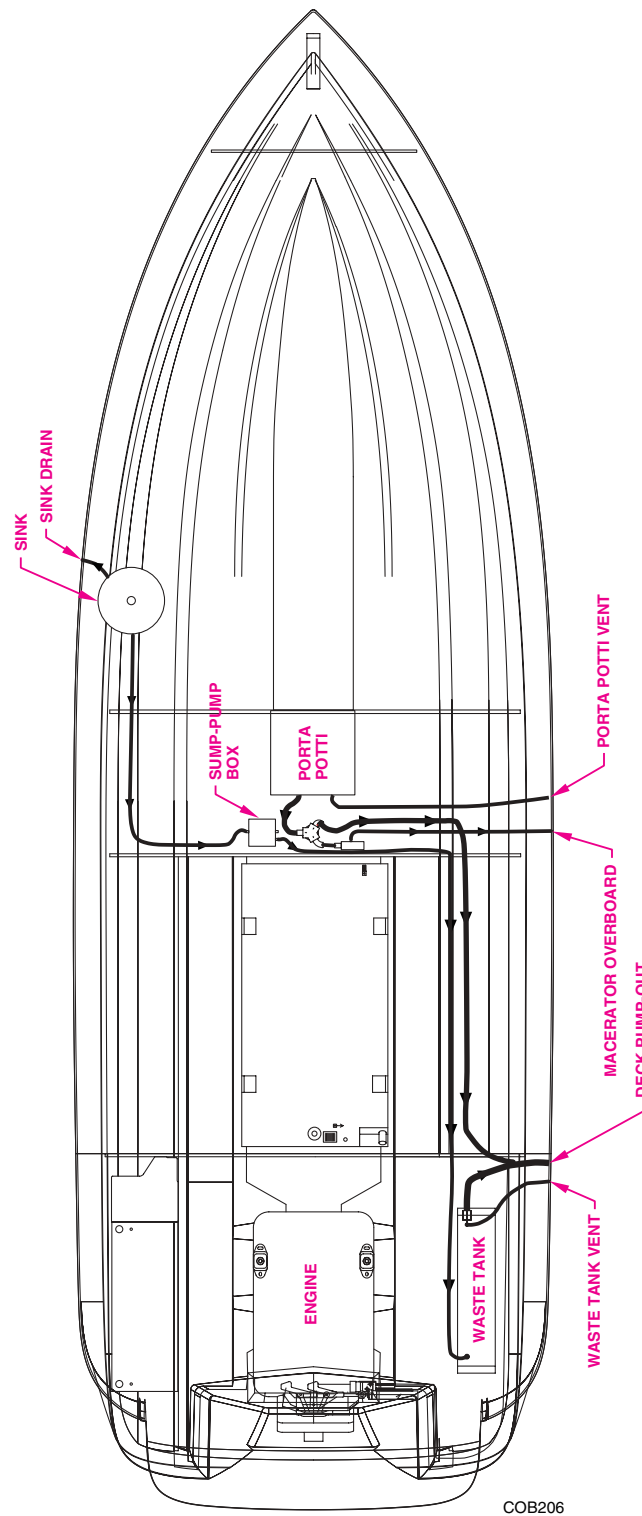



PROPELLER APPLICATION CHART

Model	Mfgr.	Engine	Drive	Fuel system	Std. Ratio	Optional Ratio	Php	Propeller Description	Mfgr. Part Number
263	MERC	5.7 L	ALPHA	2 BBL	1.47	1.62	250		
263	MERC	5.7 L	BRAVO 1	2 BBL	1.65	1.65	250		
263	MERC	5.7 L	BRAVO 3	2 BBL	2.2	2.43	250		
263	MERC	5.0 L MPI	ALPHA	MPI	1.47	1.62	260		
263	MERC	5.0 L MPI	BRAVO 1	MPI	1.65	1.65	260		
263	MERC	5.0 L MPI	BRAVO 3	MPI	2.2	2.43	260		
263	MERC	350 MAG MPI	ALPHA	MPI	1.47	1.62	300		
263	MERC	350 MAG MPI	BRAVO 1	MPI	1.5	1.65	300	15 MIR RH	48-19838A46
263	MERC	350 MAG MPI	BRAVO 3	MPI	2.0	2.2	300	24'S B-3	48-823665A60/66A60
263	MERC	350 MAG MPI-HZN	BRAVO 3	MPI			300	24'S B-3	48-823665A60/66A60
263	MERC	6.2 MX MPI	BRAVO 1	MPI	1.65	1.65	320		
263	MERC	6.2 MX MPI	BRAVO 3	MPI	2.2	2.43	320	24'S B-3	48-823665A60/66A60
263	MERC	496 MAG MPI	BRAVO 1	MPI	1.50	1.65	375	19 MIR RH	48-13700A46
263	MERC	496 MAG MPI	BRAVO 3	MPI	1.81	2.2	375	24'S B-3	48-823665A60/66A60
263	MERC	496 MAG HO	BRAVO 1	MPI	1.50	1.65	425	23 MIR RH	48-13704A46
263	MERC	496 MAG HO	BRAVO 3	MPI	1.81	2.2	425	24'S B-3	48-823665A60/66A60
263	MERC	496 MAG HO-XZ	BRAVO 1	MPI			425		
263	VOLVO	5.7 GL	SX	2 BBL	1.51	1.6	260		
263	VOLVO	5.7 GL	DP	2 BBL	1.95	2.32	260		
263	VOLVO	5.0 GXi	SX	TBI	1.6	1.79	270		
263	VOLVO	5.0 GXi	DP	TBI	1.95	2.32	270	F4'S	3851494
263	VOLVO	5.7 Gi	SX	TBI	1.51	1.51	280		
263	VOLVO	5.7 Gi	DP	TBI	1.95	1.95	280		
263	VOLVO	5.7 GXi	SX	TBI	1.51	1.51	320		
263	VOLVO	5.7 GXi	DP	TBI	1.95	1.95	320	F5'S	3851495
263	VOLVO	8.1 Gi	DP	MFI	1.78	1.78	375	F7'S	3851497
263	VOLVO	8.1 GXi	DP	MFI	1.78	1.78	420	F7'S	3851497



MODEL SPECIFIC INFORMATION

COBALT BOATS - OWNER'S MANUAL

282

LAYOUT AND SPECIFICATIONS

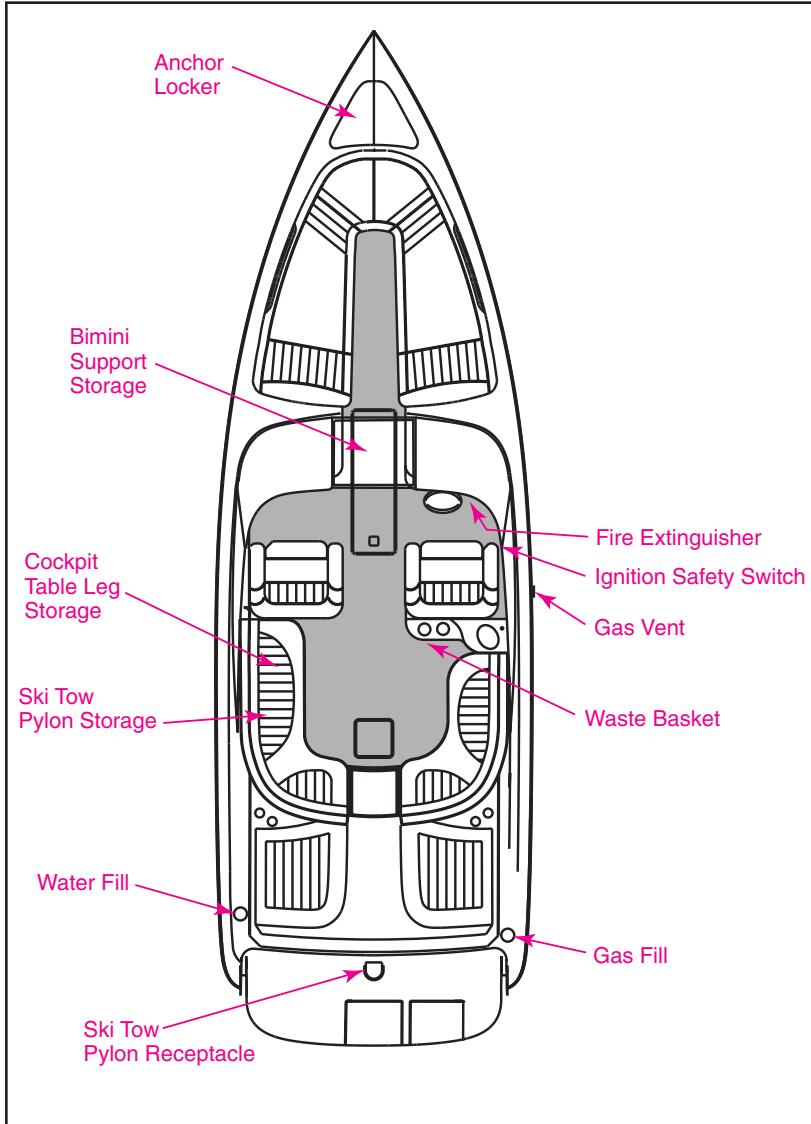

SPECIFICATIONS - SINGLE ENGINE

Style	Bowrider	
Centerline	.28'8"	8.78 m
Beam	.90"	2.74 m
Dry Weight	.6750 lbs.	3062 kg
Deadrise	.22 deg.	22 deg.
Fuel Capacity	.90 gal.	341 L
Draft(drive up)	.23"	58 cm
Draft(drive down)	.31"	79 cm
Freeboard(fwd)	.42"	107 cm
Freeboard(aft)	.45"	114 cm
Bridge Clearance	.67"	1.70 m
Freshwater Capacity	.18 gal.	68 L
Capacity, weight	Yacht Certified	
Capacity, persons	Yacht Certified	

SPECIFICATIONS - TWIN ENGINE

Style	Bowrider	
Centerline	.28'8"	8.78 m
Beam	.90"	2.74 m
Dry Weight	.7750 lbs.	3515 kg
Deadrise	.22 deg.	22 deg.
Fuel Capacity	.90 gal.	341 L
Draft(drive up)	.25"	63.5 cm
Draft(drive down)	.33"	84 cm
Freeboard(fwd)	.42"	107 cm
Freeboard(aft)	.45"	114 cm
Bridge Clearance	.67"	1.70 m
Freshwater Capacity	.18 gal.	68 L
Capacity, weight	Yacht Certified	
Capacity, persons	Yacht Certified	



CAPTAIN'S CHAIR ADJUSTMENT AND OPERATION

Your captain's chair has the flip-up position for greater visibility and maneuverability while docking. You can sit on the raised cushion or stand in front of the cushion.

The chairs are adjustable fore and aft.

Fore and Aft Adjustment - A handle on the seat allows the seat to move. Make sure the mechanism is properly engaged to prevent seat movement while the boat is underway.



WARNING

DRIVING WHILE STANDING UP IS AN EXTREMELY HAZARDOUS PRACTICE. DO NOT DRIVE WHILE STANDING AT SPEEDS GREATER THAN "IDLE SPEED."



CAUTION

ALL SEATS MUST BE IN A LOCKED/SECURED POSITION WHILE THE BOAT IS UNDERWAY.

INSTRUMENT PANEL - SINGLE ENGINE

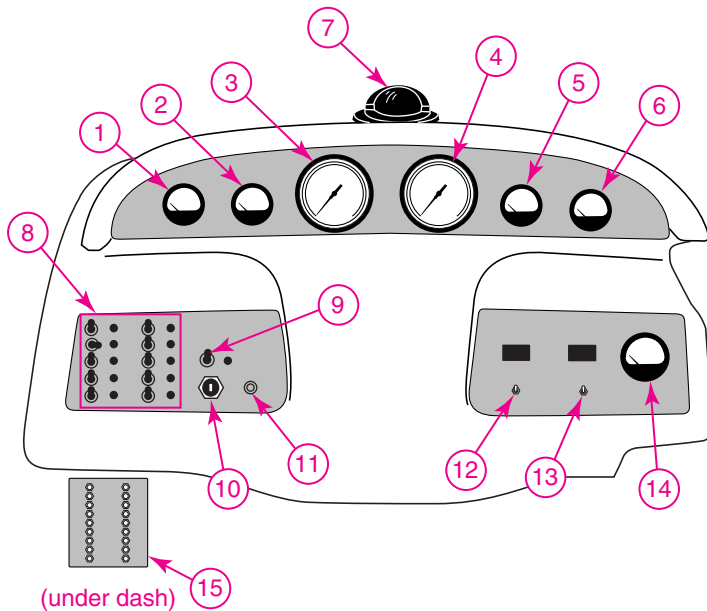

1. Fuel Gauge - Shows approximate amount of fuel remaining in tank.
2. Voltmeter - Shows the condition of charge in the battery. It only indicates while the ignition is in the "ON" position. With the engine at idle or not running, it may show as low as 10 to 12 volts. With the engine running at cruising speeds and above, it should show 12 to 14 volts.
3. Speedometer (Miles Per Hour)
4. Tachometer (Revolutions Per Minute)
5. Temperature Gauge - Temperature may fluctuate slightly while running. Maximum temperature may vary depending on type of engine.
6. Oil Pressure Gauge - Pressure can vary according to type of engine. It is normal for a hot engine to have low pressure at idle (depending on type of oil, pressure may drop as low as 10 PSI at idle).
7. Compass - To aid in navigation. For operating information refer to the compass user's manual in your owner's packet.



WARNING

SHOULD WATER TEMPERATURE REACH 180 DEGREES FAHRENHEIT, YOUR ENGINE IS OVERHEATING AND SHOULD BE CHECKED IMMEDIATELY FOR PROBABLE CAUSE.



8. Switch Panel – Power panel for miscellaneous accessories.
9. Blower Switch - Activates the engine compartment ventilation blower to remove explosive fumes from the area.
10. Ignition Key Switch
11. Horn Button - The horn is located under the deck.
12. Air/Water Temperature Gauge - Moving the toggle switch below the gauge allows you to go between air and water temperature readings. The gauge will display AIR and WATER to indicate which temperature source is in use.
13. Depth Sounder - Your Cobalt is equipped with a depth sounder. To see your options - shallow, deep, keel depth and units - toggle switch to down position. To set each option to desired reading toggle switch to up position. Consult your Cobalt Dealer for further information.
14. Trim Gauge - Shows the position of the drive unit in reference to the bottom of the boat.
15. Circuit Breaker Panel (located under dash) - Push circuit breaker buttons to reset if necessary. If a button continues to pop out consult your Cobalt Dealer.

INSTRUMENT PANEL - TWIN ENGINE

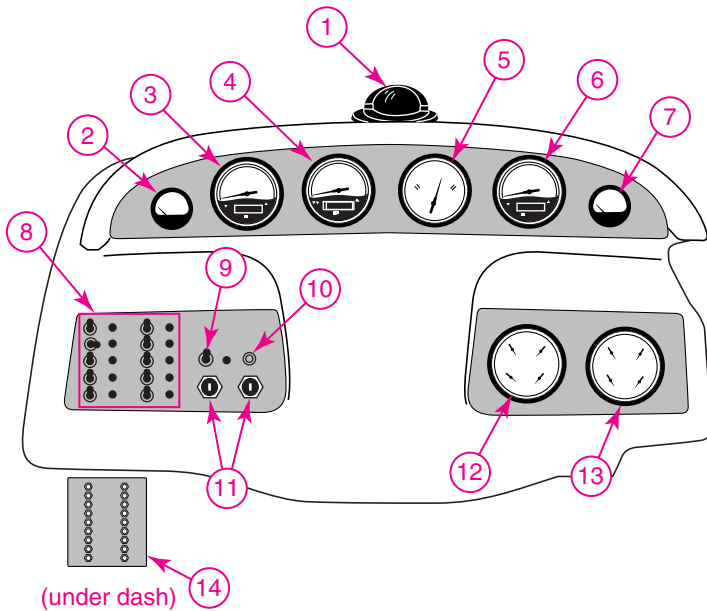

1. Compass - To aid in navigation. For operating information refer to the compass user's manual in your owner's packet
2. Trim Gauge - Port – Shows the position of the drive unit in reference to the bottom of the boat.
3. Tachometer (Revolutions Per Minute)/Air-Water Temperature Gauge Combination – See instructions in owner's packet for more information or consult your Cobalt Dealer.
4. Speedometer (Miles Per Hour)/Depth Gauge Combination – See instructions in owner's packet for more information or consult your Cobalt Dealer.
5. Synchronizer Gauge – Compares both engine RPMs.
6. Tachometer (Revolutions Per Minute)/Air-Water Temperature Gauge Combination – See instructions in owner's packet for more information or consult your Cobalt Dealer.

7. Trim Gauge - Starboard
8. Switch Panel – Power panel for miscellaneous accessories.
9. Blower Switch - Activates the engine compartment ventilation blower to remove explosive fumes from the area.
10. Horn Button - The horn itself is located under the deck.
11. Ignition Key Switches – Each engine has its separate ignition switch.



12. Cluster Gauge – Port

Fuel – Measures approximate level of fuel in tank.

Oil Pressure – Measures the pressure of the engine’s lubricating oil.

Voltmeter – Indicates the condition of the engine’s cranking battery in volts DC.

Temperature – Indicates the water/coolant temperature inside the engine.

13. Cluster Gauge – Starboard (same as port without fuel gauge)

Fuel – Measures approximate level of fuel in tank.

Oil Pressure – Measures the pressure of the engine’s lubricating oil.

Voltmeter – Indicates the condition of the engine’s cranking battery in volts DC.

Temperature – Indicates the water/coolant temperature inside the engine.

14. Circuit Breaker Panel (located under dash) - Push circuit breaker buttons to reset if necessary. If a button continues to pop out consult your Cobalt Dealer.

EXTENDED SWIM PLATFORM – OPTIONAL

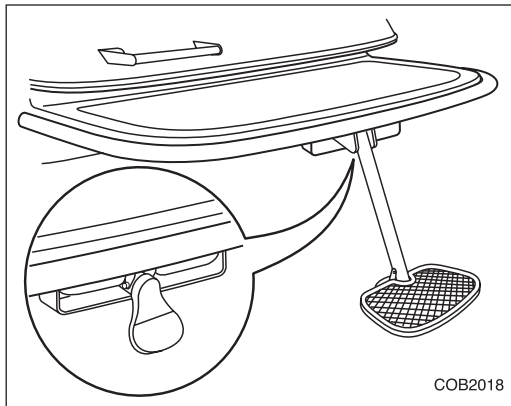

The swim platform was designed for use by people – not for the storage of personal equipment. Maximum platform weight capacity is 800 pounds. If the swim platform is removed the boat will not pass Coast Guard inspection, and the boat cannot be boarded until a boarding ladder has been installed on the swim deck. To purchase a boarding ladder consult your Cobalt Dealer.

Use the release lever to release the ladder and telescope to full length. Lift ladder and press into stow position. Use caution when stowing the ladder to prevent pinching fingers.



WARNING

DO NOT OCCUPY EXTENDED SWIM PLATFORM WHILE ENGINE IS RUNNING OR ENGAGED. PROPELLER CONTACT MAY CAUSE SEVERE INJURY OR FATALITY. ALL GASOLINE POWERED ENGINES PRODUCE CARBON MONOXIDE (CO). CO IS COLORLESS, ODORLESS, AND DANGEROUS. DIRECT AND PROLONGED EXPOSURE TO CO WILL CAUSE BRAIN DAMAGE OR DEATH.

WINDSHIELD HOOK

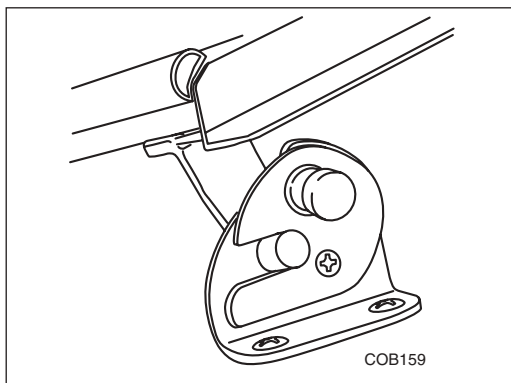

To open the windshield make sure the vertical slots in the mechanism are aligned. Swing the windshield open until the windshield post falls into the vertical slots and the mechanism locks.

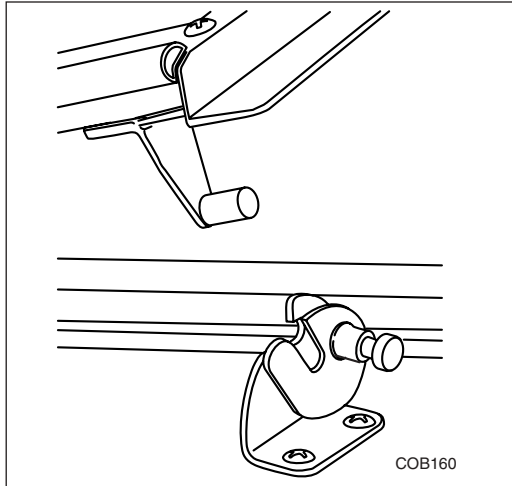

To close the windshield release the locking mechanism by pulling the forward-facing button. Swing the windshield into place.

WATER SYSTEM

If your Cobalt is equipped with an optional transom shower, standard or optional galley, the system allows for an 18-gallon capacity water system. A 12VDC water pump operates the system. It is necessary for the ship's batteries to be turned ON for the water system to operate. Consult your Cobalt Dealer for winterization requirements.

To clean the water tank, the manufacturer recommends adding 1/4 cup of baking soda into the tank and allowing the tank to stand for one day, then flushing the tank twice. If this is not sufficient to clean the tank, replace the baking soda with 2 tablespoons of bleach and repeat the procedure.

WATER LEVEL INDICATOR

The indicator system shows the level of water in the freshwater tank (31-gallon capacity) and the waste holding tank (25-gallon capacity). The panel is a nine-light panel and indicates as follows:

FRESHWATER

Red light	Empty
Amber light	Mid
Green light	Full

WASTE TANK

Red light	Full
Amber light	Mid
Green light	Empty

CARE FOR YOUR WOOD (WATERFALL BUBINGA) DASH

- Wipe the wood surface clean with a water-moistened soft cloth. For stubborn dirt and stains use a small amount of mild non-abrasive detergent (Dove, Dawn, etc.) on a moistened cloth and gently clean the area.
- Wipe surface dry with a soft non-abrasive cloth.
- Avoid flushing the wood trim with water.
- Do not use Armor All or other marine protectants.
- Apply a light coat of non-abrasive Carnauba paste to protect the surface.



CARE FOR YOUR (OPTIONAL) TEAK SWIM PLATFORM

To keep teak in top condition, clean it occasionally with a teak cleaner and reoil it at least once a season. Follow the manufacturer’s instructions and warnings carefully as some cleaners and oils may damage gelcoat, vinyl, stainless or aluminum. Avoid using rust-producing steel wool pads when cleaning. Materials can be purchased from your Cobalt dealer.



NOTE

Teak sealers and cleaners can be harmful to other materials. Make sure you thoroughly remove any spills or excess. Teak should not be varnished as the natural oils in teak will cause poor adhesion.



WARNING

DO NOT STORE RAGS USED TO TREAT TEAK ON BOARD; STORE OR DISPOSE OF RAGS PROPERLY ASHORE.

MOTOR BOX ASSEMBLY

Electric – The electric motor box assembly is controlled by a switch on the dash. If you experience a battery failure, the assembly can be opened manually. Make sure the ski tow is removed before opening the motor box or damage will occur.

COCKPIT DINETTE TABLE - OPTIONAL

Remove the j-shaped table leg from the storage area. Slide socket cover up and insert the leg. Tighten thumbs screws on the leg for desired tightness. Slide the table top onto the leg and tighten with knob.

JUMP START STUD

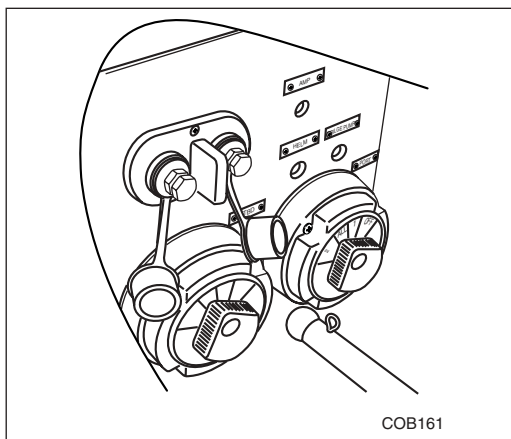

This receptacle allows for “jump starting” of the engines. The receptacles have protective covers. Be sure the covers are installed when receptacles are not being used. These can be used, when the batteries are low or removed, to raise the engine compartment.



PERFECT PASS - OPTIONAL

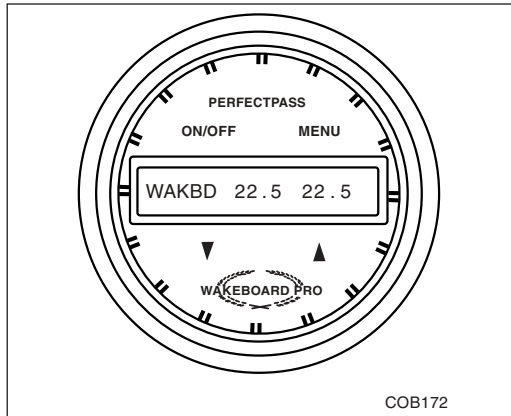

To operate the Perfect Pass speed control system set desired speed on Perfect Pass. Once your boat reaches the set speed Perfect Pass takes over and holds the speed constant. For additional operating information refer to operator's manual.

AFT WALK-THRU FILLER CUSHIONS – OPTIONAL

Individual sun pads can be converted into a large sundeck over the motor box by installing the optional aft filler cushion. When installing the cushion, ensure the barrel bolts on the underside are secured before using.

TELESCOPING ANCHOR LIGHT

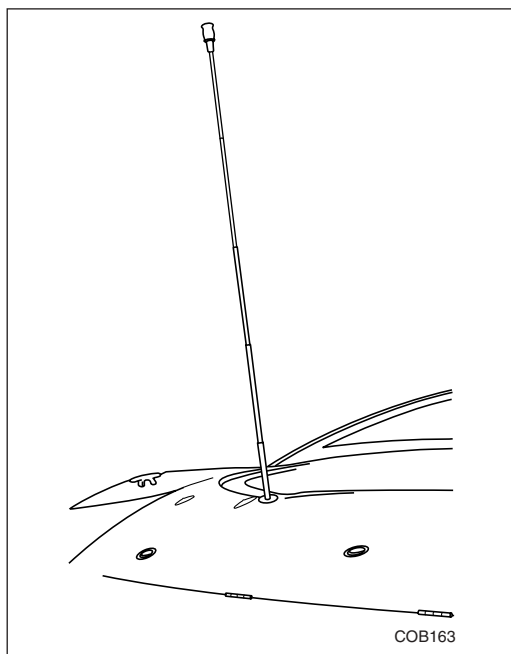

To activate, turn on the navigation light switch. The anchor light will first raise into position, then illuminate. When the light switch is turned off, the light will immediately turn off and after a 1.5 second computer check, the pole will automatically retract into its below-deck storage position. The top of the lens will be flush with the top of the deck ring. If the light does not retract automatically, do not force down, contact your Cobalt Dealer.

To operate the S.O.S. distress signal, turn on the anchor light and allow it to fully extend and illuminate. Wait a minimum of two seconds as the light runs a circuit check. Anytime thereafter, you may toggle the light switch (rapidly turning the light off and immediately back on). The light will start to flash the Morse code S.O.S. and continue flashing S.O.S. until it is toggled again. The light will then illuminate constantly. You may turn the anchor light off in either mode and it will retract automatically.



TELESCOPING BOARDING LADDER

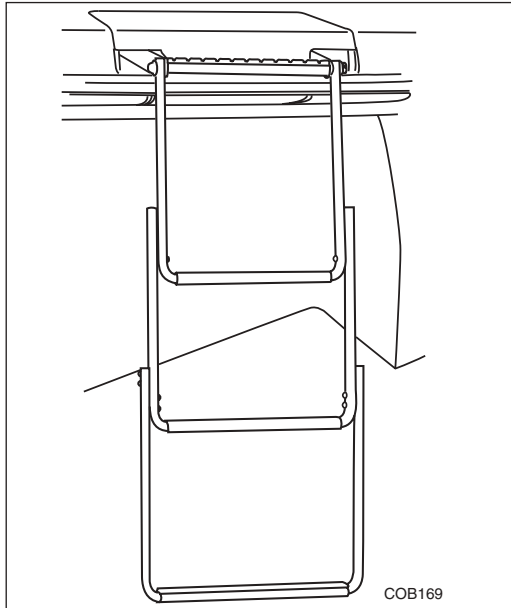

LADDER MUST ONLY BE USED WHILE THE ENGINE IS OFF. (See warning label section.) Be sure the ladder is raised and secured prior to starting engine. Exercise caution while using the ladder.



WARNING

DO NOT USE BOARDING LADDER WHILE ENGINE IS RUNNING.



CAUTION

THE STERN DRIVE UNIT HAS MANY SHARP EDGES, ESPECIALLY THE PROPELLER. EXERCISE CAUTION WHEN NEAR THE STERN DRIVE UNIT. ALWAYS MAKE SURE THE BOARDING LADDER IS PROPERLY STOWED AND THERE IS NO ONE IN THE AREA BEHIND THE BOAT BEFORE STARTING THE ENGINE AND ENGAGING THE SHIFT MECHANISM.

HEAD COMPARTMENT

1. Make sure the head compartment door assembly is closed and latched while the boat is underway. Do not allow door to swing freely.
2. For operation of the standard pump out, electric head or macerator, please check the manuals supplied in your owner's packet. Refer to page 69 of this manual for more information.

COCKPIT HEATER - OPTIONAL

To winterize, remove the two 5/8" cockpit heater hoses from the engine. Pump antifreeze into one hose until entire heater system is filled.



AIR COMPRESSOR

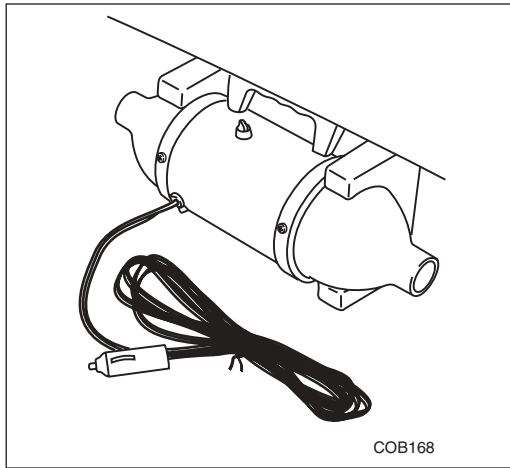

A high volume air pump is conveniently located in the aft sundeck storage compartment to inflate your favorite water toys. Plug into the accessory receptacle on the dash or in the air compressor area.

WINDLASS - OPTIONAL

The windlass allows labor free anchor deployment and retrieval.



NOTE

The windlass is designed to deploy and retrieve the rode and lift the anchor. It is not designed to hold the rode while anchored, as the brake may not hold securely. After the anchor is deployed, attach the rode to a cleat to hold the boat securely. A windlass uses a high level of electrical current under load; running the engine will help to keep the batteries charged while using the windlass.

The Windlass system gets its power from the ship's electrical system (12 VDC) via a control panel located in the port side storage compartment of the cockpit next to the battery switches. The knob on the panel must be depressed to energize the system denoted by the indicator light on the panel. The windlass can be operated at the driver's helm (indicator light must be illuminated) or from the foredeck. There are foot operated switches located under the anchor locker door.

The Windlass system can also be operated manually. In the anchor locker on the foredeck, you will find a crank housed in a storage pouch on the aft bulkhead of the locker. Please consult the operator's manual supplied with the Windlass system for proper operation of the system in the electric and manual modes.



FUEL ROUTING

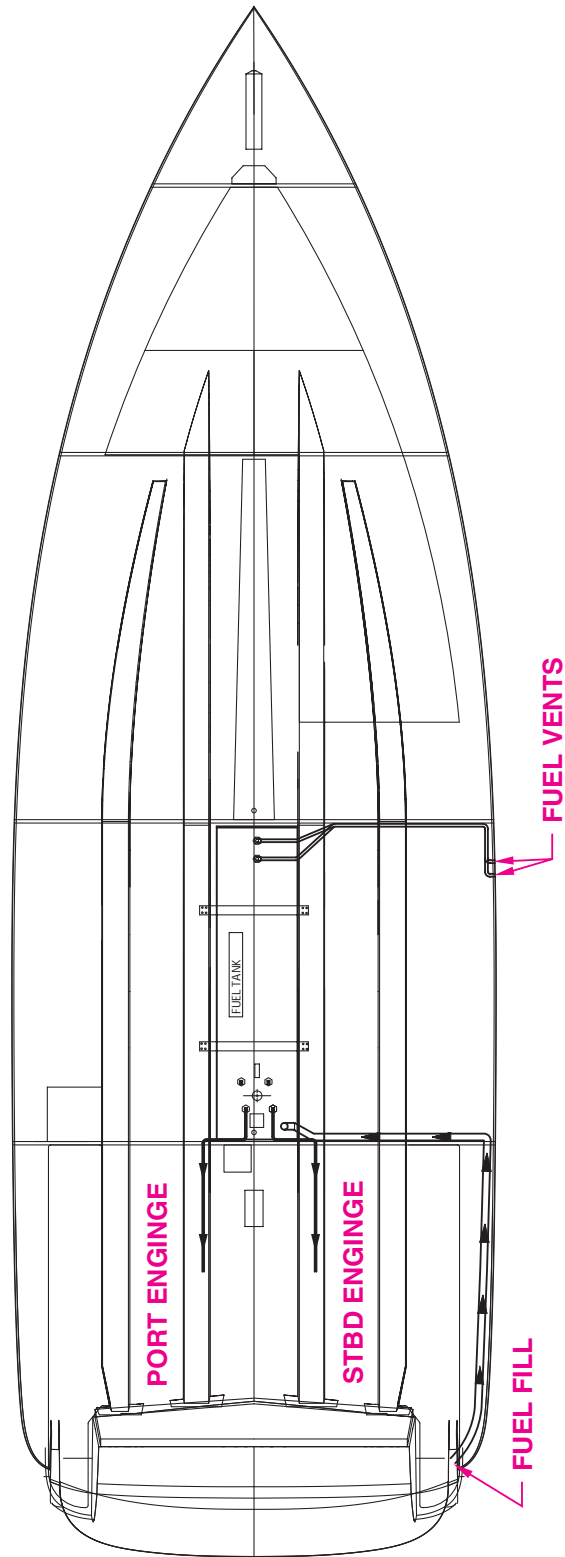

COB208



FRESH WATER PLUMBING

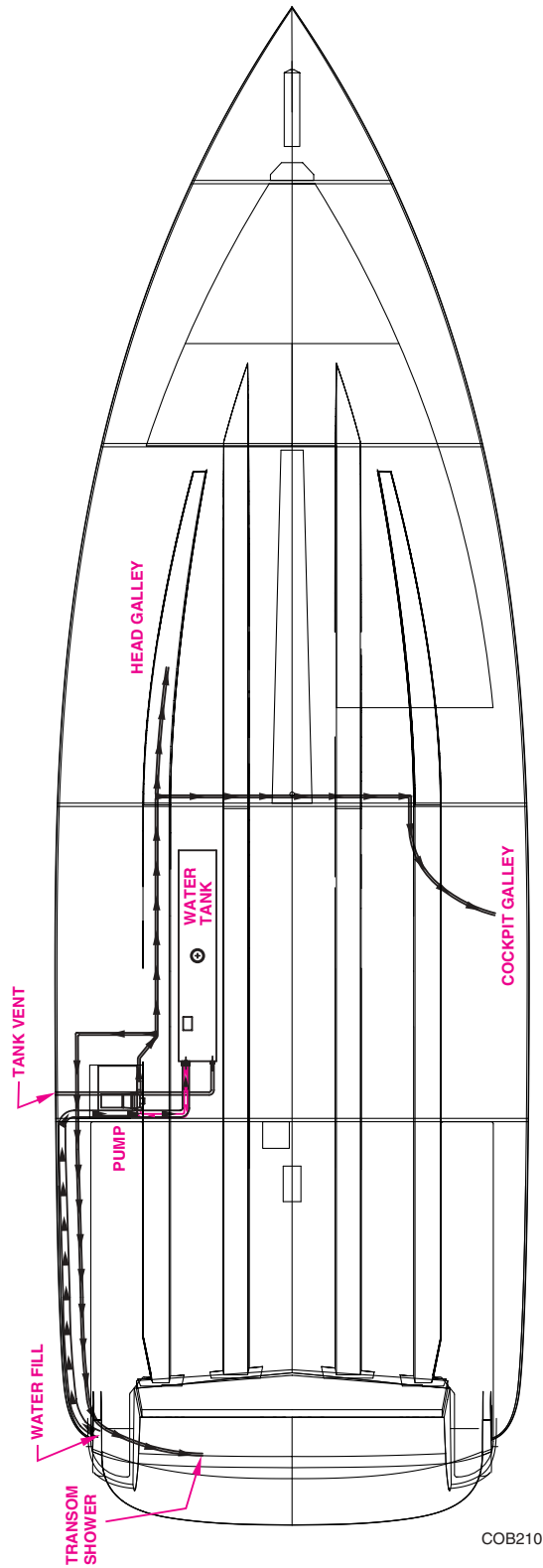



GRAY WATER PLUMBING

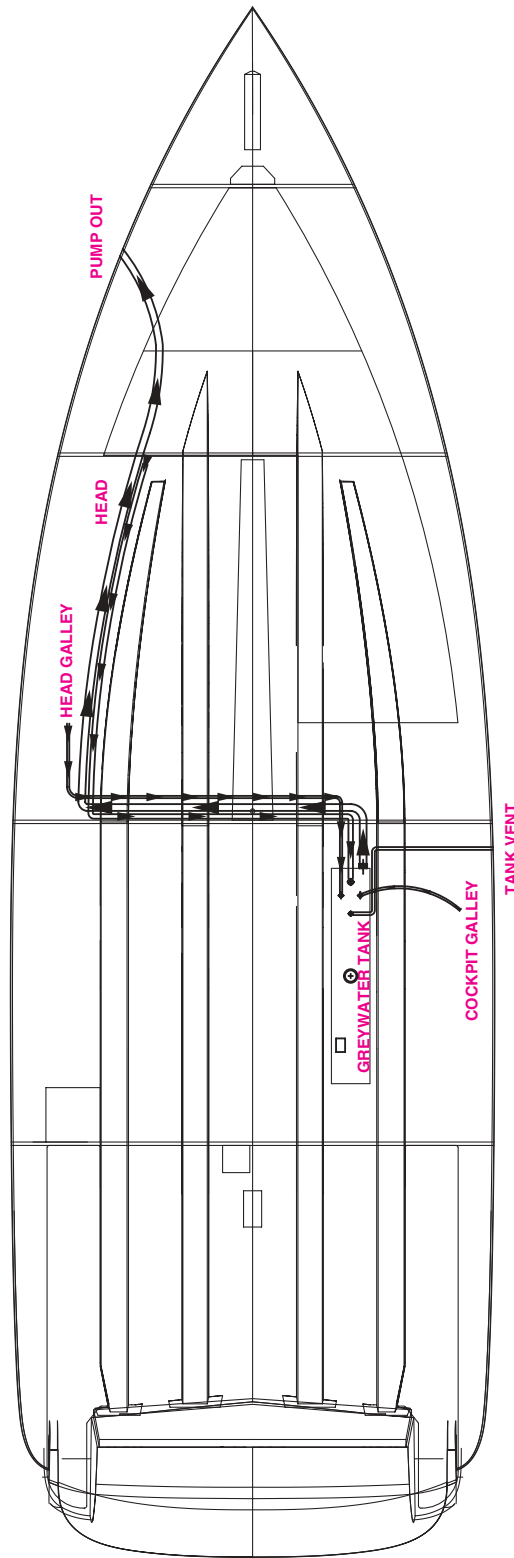

COB209



PROPELLER APPLICATION CHART

Model	Mfgr.	Engine	Drive	Fuel system	Std. Ratio	Optional Ratio	Php	Propeller Description	Mfgr. Part Number
282	MERC	6.2 MX MPI	BRAVO 1	MPI	1.65	1.65	320		
282	MERC	6.2 MX MPI	BRAVO 3	MPI	2.2	2.43	320		
282	MERC	496 MAG MPI	BRAVO 1	MPI	1.5	1.65	375	19 MIR RH	48-13700A46
282	MERC	496 MAG MPI	BRAVO 3	MPI	2	2.2	375	24'S B-3	48-823665A60/66A60
282	MERC	496 MAG HO	BRAVO 1	MPI	1.5	1.65	425		
282	MERC	496 MAG HO	BRAVO 3	MPI	1.81	2.2	425	22'S B-3	48-823663A60/64A60
282	MERC	496 MAG HO-XZ	BRAVO 1	MPI			425		
282	MERC	TWIN 4.3 L MPI	ALPHA	MPI	1.62	1.81	220		
282	MERC	TWIN 4.3 L MPI	BRAVO 3	MPI	2.2	2.43	220		
282	MERC	TWIN 5.0 L	ALPHA	2 BBL	1.62	1.81	220		
282	MERC	TWIN 5.0 L	BRAVO 1	2 BBL	1.65	1.65	220		
282	MERC	TWIN 5.0 L	BRAVO 3	2 BBL	2.2	2.43	220		
282	MERC	TWIN 5.7 L	ALPHA	2 BBL	1.47	1.62	250		
282	MERC	TWIN 5.7 L	BRAVO 1	2 BBL	1.65	1.65	250		
282	MERC	TWIN 5.7 L	BRAVO 3	2 BBL	2.2	2.43	250		
282	MERC	TWIN 5.0 L MPI	ALPHA	MPI	1.47	1.62	260		
282	MERC	TWIN 5.0 L MPI	BRAVO 1	MPI	1.65	1.65	260		
282	MERC	TWIN 5.0 L MPI	BRAVO 3	MPI	2.2	2.43	260	28'S B-3	48-823669A60/70A60
282	MERC	TWIN 350 MAG MPI	ALPHA	MPI	1.47	1.62	300		
282	MERC	TWIN 350 MAG MPI	BRAVO 1	MPI	1.5	1.65	300	19'S MIR	48-13701A46/00A46
282	MERC	TWIN 350 MAG MPI	BRAVO 3	MPI	2.0	2.2	300	26'S B-3	48-823667A60/68A60
282	MERC	TWIN 350 MAG MPI-HZN	BRAVO 3	MPI	2.0	2.2	300	26'S B-3	48-823667A60/68A60
282	MERC	TWIN 6.2 MX MPI	BRAVO 1	MPI	1.65	1.65	320		
282	MERC	TWIN 6.2 MX MPI	BRAVO 3	MPI	2.2	2.43	320	28'S B-3	48-823669A60/70A60
282	MERC	TWIN 496 MAG MPI	BRAVO 1	MPI	1.50	1.65	375		
282	MERC	TWIN 496 MAG MPI	BRAVO 3	MPI	1.81	2.2	375	28'S B-3	48-823669A60/70A60
282	VOLVO	5.7 GXi	SX	TBI	1.51	1.51	320		
282	VOLVO	5.7 GXi	DP	TBI	1.95	1.95	320		
282	VOLVO	8.1 Gi	DP	MFI	1.78	1.78	375	F5'S	3851495
282	VOLVO	8.1 GXi	DP	MFI	1.78	1.78	420	F5'S	3851495
282	VOLVO	TWIN 5.0 GL	SX	2 BBL	1.6	1.79	220		
282	VOLVO	TWIN 5.0 GL	DP	2 BBL	1.95	2.32	220		
282	VOLVO	TWIN 4.3 GXi	SX	TBI	1.79	1.89	225		
282	VOLVO	TWIN 4.3 GXi	DP	TBI	2.32	2.32	225		
282	VOLVO	TWIN 5.7 GL	SX	2 BBL	1.51	1.6	260		
282	VOLVO	TWIN 5.7 GL	DP	2 BBL	1.95	2.32	260		
282	VOLVO	TWIN 5.0 GXi	SX	TBI	1.6	1.79	270		
282	VOLVO	TWIN 5.0 GXi	DP	TBI	1.95	2.32	270	F6'S	3851496
282	VOLVO	TWIN 5.7 Gi	SX	TBI	1.51	1.51	280		
282	VOLVO	TWIN 5.7 Gi	DP	TBI	1.95	1.95	280	F7'S	3851497
282	VOLVO	TWIN 5.7 GXi	SX	TBI	1.51	1.51	320		
282	VOLVO	TWIN 5.7 GXi	DP	TBI	1.95	1.95	320	F8'S	3851498
282	VOLVO	TWIN 8.1 Gi	DP	MFI	1.78	1.78	375	F9'S	3851499



MODEL SPECIFIC INFORMATION

COBALT BOATS - OWNER'S MANUAL

293

LAYOUT AND SPECIFICATIONS

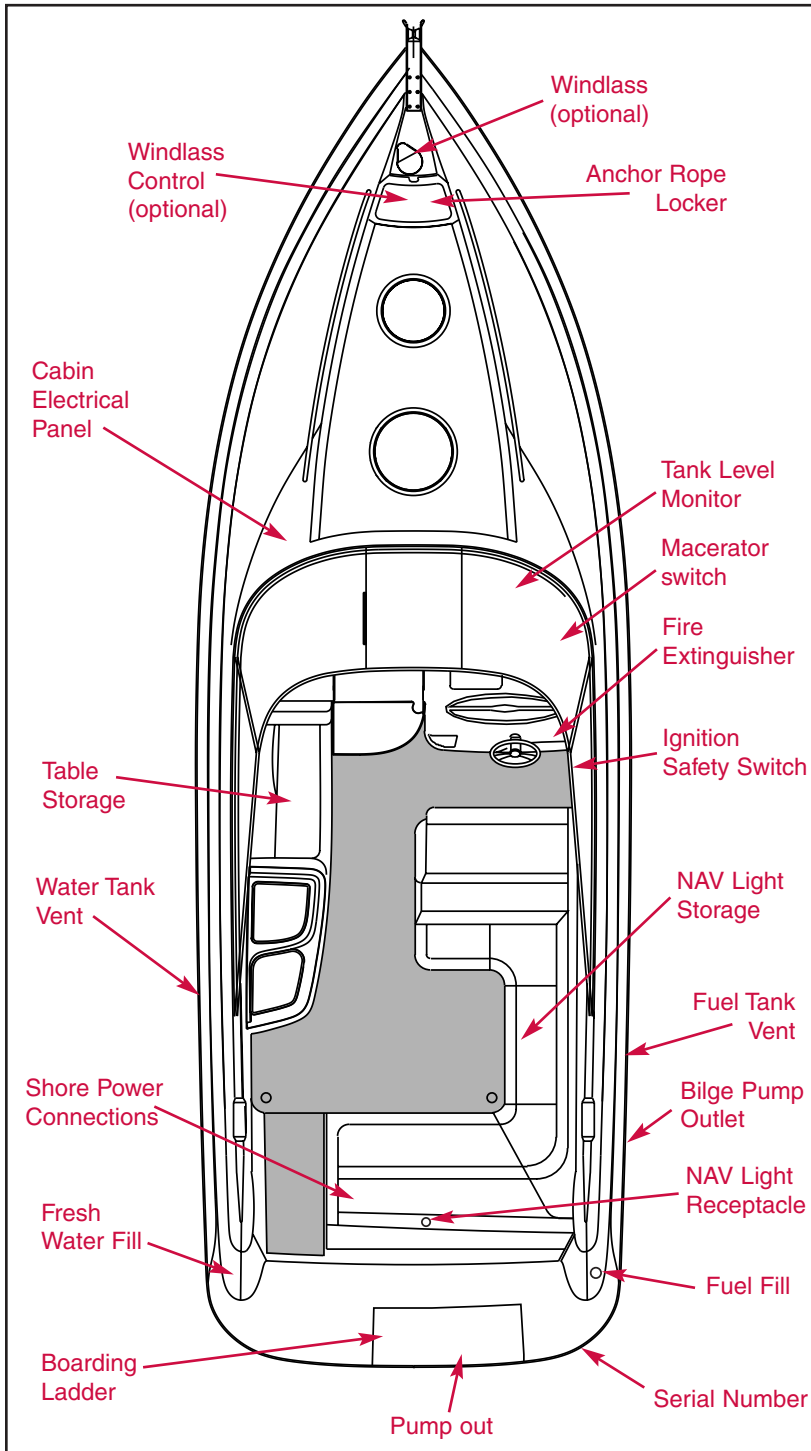

SPECIFICATIONS

Centerline(w/ anc roller)	.29'5"	9.1 m
Centerline(w/o anc roller)	28'10"	8.8 m
Beam	9' 6"	2.89 m
Fuel Capacity	111 gal.	420 l
Dry Weight(single)	.6950 lbs.	3051 kg
Dry Weight(twin eng.)	.7950 lbs.	3606 kg
Deadrise(transom)	.20 deg.	20 deg.
Draft(single, drive up)	.19"	48 cm
Draft(twin, drive up)	.21"	53 cm
Cockpit Freeboard	.53"	103 cm
Transom Height	.23"	60 cm
Bridge Clearance)	.75"	190 cm
Freshwater Capacity	.31 gal.	117 l
Waste Capacity	.25 gal.	95 l
Capacity	Yacht Certified	



CAPTAIN'S CHAIR ADJUSTMENT AND OPERATION

Your captain's chair has the flip-up position for greater visibility and maneuverability while docking. You can sit on the raised cushion or stand in front of the cushion.

The chair is adjustable fore and aft.

Fore and Aft Adjustment - A handle under the front lip of the seat allows the seat to move. Make sure the mechanism is properly engaged to prevent seat movement while the boat is underway.



WARNING

DRIVING WHILE STANDING UP IS AN EXTREMELY HAZARDOUS PRACTICE. DO NOT DRIVE WHILE STANDING AT SPEEDS GREATER THAN "IDLE SPEED."



CAUTION

ALL SEATS MUST BE IN A LOCKED/SECURED POSITION WHILE THE BOAT IS UNDERWAY.

CUDDY CABIN ACCESS DOOR

The sliding door assembly can be in the open or closed position while running. Make sure the door is secured in either the open or closed position. Do not allow to slide free.

INSTRUMENT PANEL

Single Engine Instrumentation

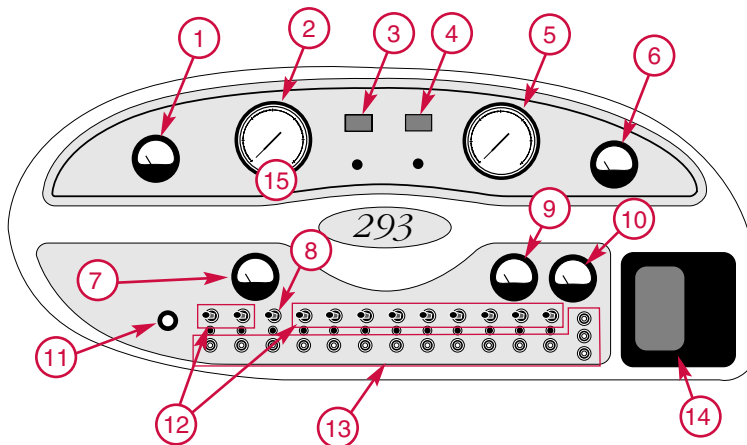

1. Fuel Gauge - shows approximate amount of fuel remaining in tank.
2. Speedometer (Miles Per Hour)
3. Depth Sounder - Your Cobalt is equipped with a depth sounder. To see your options - shallow, deep, keel depth and units - toggle switch to down position. To set each option to desired reading toggle switch to up position. Consult your Cobalt Dealer for further information.
4. Air/Water Temperature Gauge - Moving the toggle switch below the gauge allows you to go between air and water temperature readings. The gauge will display AIR and WATER to indicate which temperature source is in use.

5. Tachometer - (Revolutions Per Minute)
6. Trim Gauge - Shows the position of the drive unit in reference to the bottom of the boat.



7. Voltmeter - shows the condition of charge in the battery. It only indicates while the ignition is in the "ON" position. With the engine at idle or not running, it may show as low as 10 to 12 volts. With the engine running at cruising speeds and above, it should show 12 to 14 volts.
8. Three Position Exterior Light Switch NAV. position - navigation (running) lights, bow light and stern light. Center position - off. ANC. position - stern light only.



WARNING

NEVER OPERATE YOUR BOAT AT NIGHT WITHOUT ALL OF THE REQUIRED LIGHTS OPERATING. MAKE SURE LIGHTS ARE NOT BLOCKED BY CANVAS OR OTHER OBSTACLES.

9. Oil Pressure Gauge - Pressure can vary according to type of engine. It is normal for a hot engine to have low pressure at idle, (depending on type of oil, pressure may drop as low as 10 PSI at idle). Please consult the engine owner's manual supplied with your boat concerning the oil pressure the engine in your boat should attain.
10. Temperature Gauge - Temperature may fluctuate slightly while running. Maximum temperature may vary depending on type of engine.



CAUTION

SHOULD WATER TEMPERATURE REACH 180 DEGREES FAHRENHEIT, YOUR ENGINE IS OVERHEATING AND SHOULD BE CHECKED IMMEDIATELY FOR PROBABLE CAUSE.

Twin Engine Instrumentation

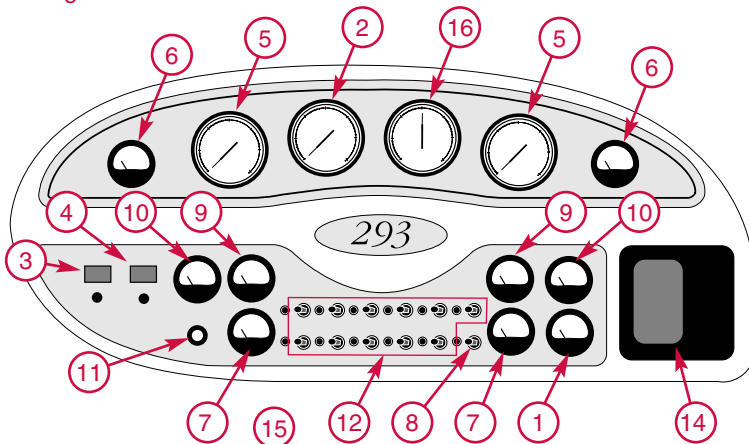

11. Dimmer Switch - Your Cobalt is equipped with a dimmer switch which controls the intensity of the dash lights including the compass light.
12. Two Position Switch - Controls equipment as labeled.
13. Circuit Breakers - Push to reset if necessary. If the button continues to pop out, consult your Authorized Cobalt Dealer.
14. GPS - Optional Global Positioning System

15. Motor box electric actuator - Controls motor box electrically. If battery is low or disconnected, the motor box can be raised manually. Simply grasp the lower forward edge of the assembly and raise. Use the safety support rod to support the assembly in the open position.

The motor box assembly is very heavy. Caution should be exercised when opening manually.

16. Synchronizer Gauge



TELESCOPING BOARDING LADDER

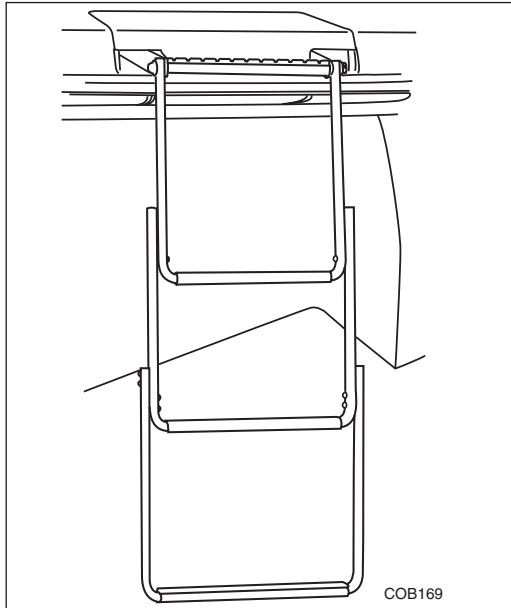

THIS LADDER MUST ONLY BE USED WHILE ENGINE IS OFF. (See warning label section). Be sure ladder is raised and secured prior to starting engine. Caution should be used while using this ladder.

Telescoping ladder is covered by ladder lid. Lift ladder lid to access ladder. Lift up on front of ladder to place overboard and telescope to full length. Use caution to prevent pinching fingers when stowing ladder.



WARNING

DO NOT USE BOARDING LADDER WHILE ENGINE IS RUNNING.



CAUTION

THE STERN DRIVE UNIT HAS MANY SHARP EDGES, ESPECIALLY THE PROPELLER. EXERCISE CAUTION WHEN NEAR THE STERN DRIVE UNIT. ALWAYS MAKE SURE THE BOARDING LADDER IS PROPERLY STOWED AND THERE IS NO ONE IN THE AREA BEHIND THE BOAT BEFORE STARTING THE ENGINE AND ENGAGING THE SHIFT MECHANISM.

DECK HATCHES

The deck hatches are manually operable. To open, simply release the one or two hasps on the edge of the hatch, make sure the support bracket adjusters are loose, and raise the hatch to the desired position and secure the adjusters.



CAUTION

DO NOT USE A RAISED HATCH FOR A SUPPORT OR HAND HOLD WHILE ON THE DECK. BE SURE HATCH IS FIRMLY SECURED WHILE UNDERWAY.

HEAD COMPARTMENT

1. Make sure the head compartment door assembly is closed and latched while the boat is underway. Do not allow to swing freely.
2. For operation of the toilet, please check the manuals supplied in your owner's packet. Refer to page 69 of this manual for information.



REFRIGERATOR - OPTIONAL

The refrigerator receives its power from the ship's electrical system (12 VDC). Inside the refrigerator is the thermostat control. The electrical system must be energized correctly at the 12 VDC/110 VAC control panel. The master 12 VDC switches must be turned on as well as the switch marked refrigerator.

BATTERY SWITCH OPERATION

Single Engine - Your Cobalt is equipped with a dual battery switch. With this switch off, nothing in the boat will operate with the exception of the automatic bilge pumps. Make sure the switch is in the "1" or "2" position. You can operate the boat with switch in the "both" position but not for extended periods.

Note: The purpose of dual batteries is to keep one as a spare. In the "both" position, you essentially have one larger battery and if a failure should occur with the electrical systems or either battery, both batteries will end up discharged.

Twin Engines - Your Cobalt is equipped with two dual battery switches. With this switches turned off nothing in the boat will operate with the exception of the automatic bilge pumps. Make sure the switches are in the "1" or "2" position. You can operate the boat with the switches in the "both" position but not for extended periods.

Note: The purpose of dual batteries is to keep one as a spare. In the "both" position, you essentially have one larger battery and if a failure should occur with the electrical systems or either battery, both batteries will end up discharged.

Dual battery switches are located under the aft starboard bench seat.

STARBOARD SWITCH CONTROLS POWER TO STARBOARD ENGINE.

- **Normal operation should be position 1.
- Position 1 connects battery 1 to starboard engine.
- Position 2 connects battery 2 to starboard engine.
- Position ALL connects batteries together and to starboard engine.
- Starboard Battery is directly wired to power all bilge pumps even with battery switch off.
- Starboard Battery also powers dash and the cabin 12VDC panel.

PORT SWITCH CONTROLS POWER TO PORT ENGINE SIMILAR TO STARBOARD.

- Normal operation should be position 2. This allows for 2 separate electrical systems.
- Starboard on battery 1 and port on battery 2.

EMERGENCY START:

- Turn battery switch to ALL.
- Do not turn switches off with engine running, as it could cause serious damage to electrical components.

EXTENDED STORAGE:

- Turn Battery switches off. Verify bilge pumps still function.



SHORE POWER - OPTIONAL

When your Cobalt is connected to shore power (110 VAC), any or all of the ship's electrical systems can be operated. The two 30-amp shore power cords must be plugged into the proper shore power receptacles and the boat receptacles located in the aft storage compartment. Energize the system at the cabin control panel by turning on the master switch(es) and then energize the appropriate switches. For example, to operate the battery charger, follow the above procedure and turn on the switch marked battery charger. With the battery charger operating, any of the 12 VDC systems; i.e., refrigerator, lighting, etc., can be used without fear of running the ship's batteries low.

The shore power system is protected by circuit breakers located in the glasses/bottle storage compartment directly behind the refrigerator on the port side. The breakers are in a panel at the back of the compartment. Note that when the shore power system is connected (110 VAC) and the correct switches are lined up at the cabin control panel, including the battery charger, the batteries in the boat will be charged. The position of the ship's battery switches (starboard side storage compartment) is irrelevant to the battery charging operation. However, the 12 VDC system in the boat will not operate unless the main battery switches are turned on.

For further information referencing the ship's shore power system, please consult your authorized Cobalt Dealer.

SHORE POWER DISTRIBUTION PANEL - OPTIONAL



CAUTION

THIS IS A SUMMARY ONLY AND DOES NOT EXPLAIN ALL OPERATION. BEFORE OPERATING THESE SYSTEMS, READ THE OWNERS MANUALS PROVIDED FOR EACH DEVICE. CONSULT QUALIFIED PERSONNEL IF YOU HAVE QUESTIONS.

GENERAL FUNCTION

The AC portion of distribution panel (black Marinetics panel #500472) receives AC power from the shore power cable, generator or inverter and distributes it through a double-pole main circuit breaker which in turn supplies the individual branch circuit breakers.

The DC portion of panel receives DC power via the battery selector switch and distributes power to the individual branch circuit breakers.

NORMAL OPERATION

Shore cords 1 and 2 plugged into shore power with "A/C source auxiliary power" switch on distribution panel set to "Shore 2." This allows use of all components as desired with shore 1 cord supplying power to the left column of breakers and shore 2 cord supplying power to the middle column of breakers.

- Verify the main safety breakers under the cockpit galley sink are turned on.
- Verify the reverse polarity light is off. If it is on, consult a qualified technician.
- Switch the top double-pole "AC main" breaker on the distribution panel to "on" and then the respective branch circuit breakers below it as needed.
- Voltage can be checked on voltmeter and total amperage will be displayed on ammeter.



USING ONLY “SHORE 1” POWER CORD

Shore 1 cord powers the left column of breakers on the panel. Any of these breakers may be used with only shore 1 cord plugged in.

The “A/C source auxiliary power” rotary switch located above the middle column of breakers selects the power source for the middle breakers. The choices are “shore 1” (pulls power from cord 1 to power middle breakers), “Off” (no power to breakers) or “shore 2” (pulls power from cord 2 to power middle breakers).

The “A/C source auxiliary power” switch on distribution panel can be set to “shore 1” to power the middle column of breakers in addition to the left column. In this configuration, all components can be used with power supplied from shore 1 cord up to a maximum of 30 amps.

GENERATOR - OPTIONAL



CAUTION

THIS IS A SUMMARY ONLY AND DOES NOT EXPLAIN ALL OPERATION. BEFORE OPERATING THESE SYSTEMS, READ THE OWNERS MANUALS PROVIDED FOR EACH DEVICE. CONSULT QUALIFIED PERSONNEL IF YOU HAVE QUESTIONS.

The generator is located in the cockpit floor storage area with a control panel at the helm and source selector switch at the Cabin Distribution Panel. The generator is used to provide A/C power when shore power is not available.

OPERATION

1. Make sure generator seacock (located forward of engine) is open
2. Turn Distribution Panel A/C main breakers off
3. Turn source selector switch to generator
4. Start generator (refer to generator owner manual) and turn on breakers, as desired
5. Do not operate generator during high speed operation



DANGER

CARBON MONOXIDE IS COLORLESS, ODORLESS AND DANGEROUS. ALL GASOLINE POWERED ENGINES AND GENERATORS EXHAUST CARBON MONOXIDE (CO). DIRECT AND PROLONGED EXPOSURE TO CO WILL CAUSE BRAIN DAMAGE OR DEATH. SIGNS OF EXPOSURE TO CO INCLUDE NAUSEA, DIZZINESS AND DROWSINESS. KEEP CABIN AND COCKPIT AREAS WELL VENTILATED. AVOID BLOCKAGE OF EXHAUST OUTLETS.



INVERTER/CHARGER - OPTIONAL



CAUTION

THIS IS A SUMMARY ONLY AND DOES NOT EXPLAIN ALL OPERATION. BEFORE OPERATING THESE SYSTEMS, READ THE OWNERS MANUALS PROVIDED FOR EACH DEVICE. CONSULT QUALIFIED PERSONNEL IF YOU HAVE QUESTIONS.



CAUTION

RISK OF ELECTRICAL SHOCK! INVERTER CAN STILL PROVIDE AC POWER EVEN IF ENGINE BATTERY SWITCHES ARE OFF. DISCONNECT ALL POWER SOURCES BEFORE SERVICING ELECTRICAL SYSTEM.

If an inverter/charger is installed, the charger will automatically charge batteries if connected to shore power and the light on the small remote panel near the distribution panel will be illuminated.

If the remote switch is “off,” the inverter will charge batteries when shore power is available, but will not provide A/C power if shore power is disconnected.

If the remote switch is “on,” the inverter will charge batteries when shore power is available and will automatically draw from battery bank and supply A/C power to the “shore 1” connection at distribution panel if the shore cord is disconnected. The middle column of breakers can also be powered by inverter if the “A/C source auxiliary power” switch is set to “shore 1.”

It is not recommended to use the inverter to power high amperage devices such as the hot water heater or air conditioner, as these components will quickly drain the battery bank.

BATTERY COMBINER OPERATION

The inverter/charger is designed with a separate 12VDC-battery bank system to provide 120VAC when shore power or generator is not available. The battery bank consists of (2) 12 VDC batteries located in the storage area fwd of the engine in the 293. These batteries can be connected to the main engine battery and charging system through a “pathmaker battery combiner.” The pathmaker has two primary functions: (1) It automatically parallels (connects together) multiple batteries when charging sources are available. (2) It automatically disconnects the starting battery from system loads when there are no active charging sources. This ensures the engine starting battery is always charged. In addition, by using the remote control switch located at the helm, all batteries can be paralleled for emergency starting.

When shore power is available, the inverter charger will automatically charge the inverter batteries first and then charge engine batteries via the pathmaker, even with battery switches off.

Normal position of toggle switches on pathmaker and remote are automatic. Pathmaker solenoids and inverter/charger are located on the bulkhead under the helm floor in the storage area aft of the steps.



EMERGENCY STARTING:

Momentarily press switch to “manual on” until green light is lit. The pathmaker then connects the batteries together for 5 minutes to provide maximum starting power.

DISABLING PATHMAKER:

Place the switch in the off “O” position. In this position, the battery banks are separated.

STOVE - OPTIONAL

The cabin-mounted, single burner, electric stove operates only on 110 VAC when the ship’s optional generator is running, inverter is being used, or the boat is connected to shore power with the appropriate switches energized.

SHOWER COMPARTMENT

With the ship’s water system turned on, the shower can be used by raising the nozzle of the sink faucet.

WATER SYSTEM

Your Cobalt is equipped with a 31-gallon capacity water system (37-gallons including hot water heater). The system is operated by a 12 VDC water pump located in the engine compartment. It is necessary for the ship’s batteries to be turned on and the appropriate switch on the cabin electrical panel to be energized for the water system to operate. Consult your Cobalt Dealer for winterization requirements.

To clean water tank, the manufacturer recommends inserting 1/4 cup of baking soda into the tank and allowing tank to stand for one day, then flush the tank twice. If this does not work replace baking soda with 2 tablespoons of bleach and repeat procedure.

WATER LEVEL INDICATOR

The indicator system shows the level of water in the freshwater tank (31-gallon capacity) and the waste holding tank (25-gallon capacity). The panel is a nine-light panel and indicates as follows:

FRESHWATER

Red light Empty
Amber light Mid
Green light Full

WASTE TANK

Red light Full
Amber light Mid
Green light Empty



NOTE

No indication is given if level is between “empty” and “mid.” If optional grey water system is installed indication is same as waste tank.

HOT WATER TANK - OPTIONAL

Your Cobalt maybe equipped with a six-gallon hot water heater. This unit operates in two modes. If your Cobalt is connected to shore power (110 VAC) simply energize the appropriate switches at the cabin control panel to turn on the 110 volt power and the switch marked “water heater.” This can be done with either the shore power or the optional generator.



During engine(s) operation, engine coolant (hot water) is circulated through a coil in the water heater, heating the fresh water. Note the hot water system as well as the entire fresh water system in your Cobalt must be winterized for proper storage.

BATTERY CHARGER AND ISOLATOR - OPTIONAL

Your Cobalt is equipped with a charging system. Anytime your boat is connected to shore power or the optional generator is running with the appropriate switches at the cabin panel energized, the battery charger will operate and keep both batteries fully charged.

In addition, the system includes a galvanic isolator system to help prevent corrosion of underwater gear. Please consult your Cobalt Dealer for further information in reference to these isolators.

WINDLASS - OPTIONAL

The windlass allows labor free anchor deployment and retrieval.



NOTE

The windlass is designed to deploy and retrieve the rode and lift the anchor. It is not designed to hold the rode while anchored, as the brake may not hold securely. After the anchor is deployed, attach the rode to a cleat to hold the boat securely. A windlass uses a high level of electrical current under load; running the engine will help to keep the batteries charged while using the windlass.

The Windlass system gets its power from the ship's electrical system (12 VDC) via a control panel located in the starboard side storage compartment of the cockpit next to the battery switches. The knob on the panel must be depressed to energize the system denoted by the indicator light on the panel. The windlass can be operated at the driver's helm (indicator light must be illuminated) or from the foredeck. There are foot operated switches located under the anchor locker door.

The Windlass system can also be operated manually. In the anchor locker on the foredeck, you will find a crank housed in a storage pouch on the aft bulkhead of the locker. Please consult the operator's manual supplied with the Windlass system for proper operation of the system in the electric and manual modes.



CAUTION

BE EXTREMELY CAREFUL WHEN ON THE FOREDECK. SEA/WIND CONDITIONS MAY MAKE USE OF AREAS OUTSIDE THE COCKPIT DANGEROUS.

AIR-CONDITIONING/HEATING - OPTIONAL

The air-conditioning system operates only on 110 VAC and will not operate unless the boat is connected to shore power or the optional generator is running. With the boat connected to shore power or with the optional generator running, it is necessary to energize the 110 VAC system at the cabin control panel and turn on the appropriate switch marked "air-conditioning." The controller for the air-conditioning is in the cabin on the starboard side in the area of the cedar lined closet. Please consult the owner's manual supplied with your Cobalt referencing the operation of the air-conditioning system.



NOTE

This is a heat pump system and will not only air-condition the cabin, but also supply heat on cold days. Marine air-conditioning heat pump systems must be winterized for proper storage.

GLOBAL POSITIONING SATELLITE (GPS) SYSTEM - OPTIONAL

The GPS system in your Cobalt performs many functions. The system can precisely tell you your location, form a trip record, a speed log, and many other functions. In addition, individual mapping chips can be purchased through your Cobalt Dealer for most lakes, rivers, and coastal areas of the United States and Canada. Please consult your Cobalt Dealer for further information referencing these chips. Take some time to thoroughly read and understand the manuals supplied with your GPS to take advantage of the system to its fullest capability.

WINDSHIELD HOOK

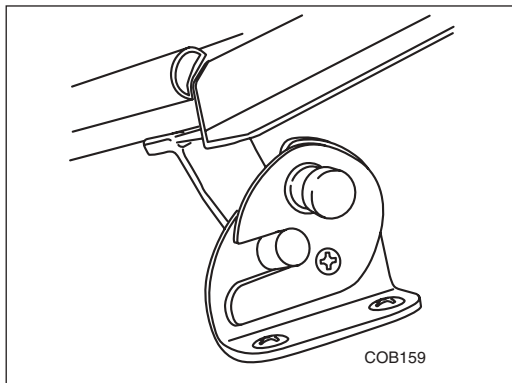

To open the windshield make sure the vertical slots in the mechanism are aligned. Swing the windshield open until the windshield post falls into the vertical slots and the mechanism locks.

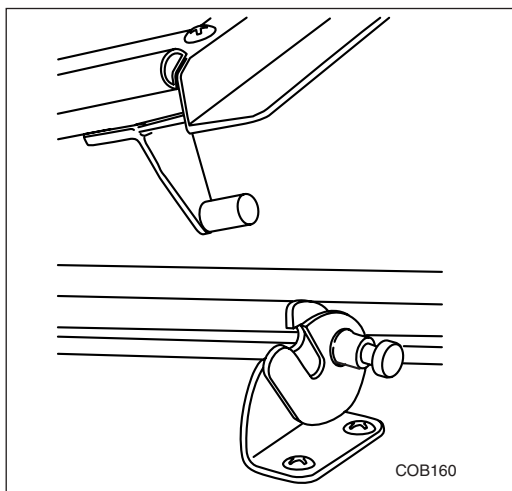

To close the windshield release the locking mechanism by pulling the forward-facing button. Swing the windshield into place.



ANCHOR LIGHT

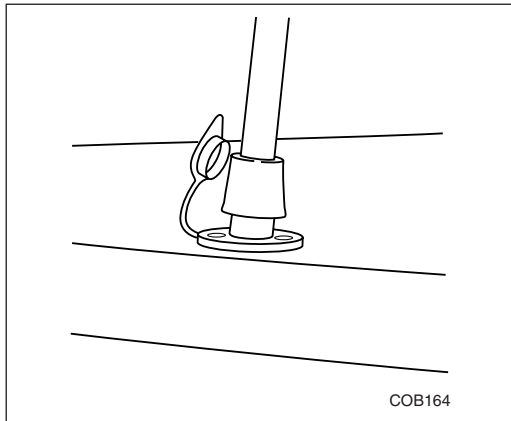

To install anchor light insert pole into socket and turn clockwise until it locks into place.

ROSEWOOD DASH (OPTIONAL) CARE

Your Rosewood veneer dash will maintain its natural beauty and high-gloss sheen when properly maintained.

- For routine cleaning wipe the wood surface with a damp soft cotton cloth. For thorough cleaning wash surface with a mild solution of soap and water, and dry with a soft cotton cloth.
- Wax or rubbing compound can be used occasionally when necessary.
- Apply liquid wax product lightly with your fingertips. Work from the center of the wood surface outward. Rub in a circular motion and stop about 1/4 inch from exterior edges of the wood. Remove wax with a clean soft cloth.
- For difficult-to-clean surfaces 3M Perfect-It III rubbing compound and a 3M “Type T” scrubbing pad can be used. Use rubbing compound carefully following manufacturer’s instructions.
- Do not use cleaners or polishes containing alcohol, ammonia, abrasives, oily emollients or petroleum-based materials.
- Avoid saturating edges of wood laminate with polish or wax. In some instances foam-backed tape used in manufacturing will absorb and retain these substances and result in premature fading and/or discoloration of your Rosewood dash. If cleaners or waxes come in contact with edges of the wood laminate, clean the surface immediately with a mild solution of soap and water.

MOTOR BOX ASSEMBLY

Electric – The electric motor box assembly is controlled by a switch on the dash. If you experience a battery failure, the assembly can be opened manually.



COCKPIT DINETTE TABLE WITH FILLER CUSHIONS - OPTIONAL

Table – Remove the long table leg from storage area and insert into floor receptacle.

Remove the table from storage area and slide on to the leg.

Filler Cushions – Remove the short table leg from storage area and insert into floor receptacle. Remove the table from storage area and slide on to the leg. Place the two filler cushions on the tabletop.

COCKPIT HEATER - OPTIONAL

To winterize, remove the two 5/8" cockpit heater hoses from the engine. Pump antifreeze into one hose until entire heater system is filled.

PERFECT PASS - OPTIONAL

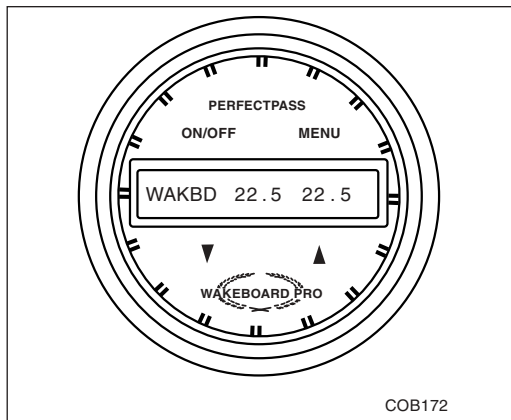

To operate the Perfect Pass speed control system set desired speed on Perfect Pass. Once your boat reaches the set speed Perfect Pass takes over and holds the speed constant. For additional operating information refer to operator's manual.

AIR COMPRESSOR

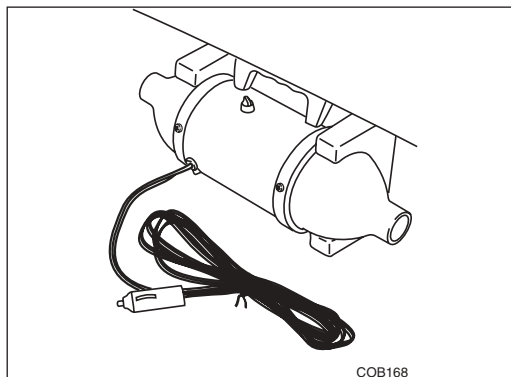

A high volume air pump is conveniently located in the aft deck storage compartment to inflate your favorite water toys. Plug into the accessory receptacle on the dash or in the air compressor area.



FUEL ROUTING

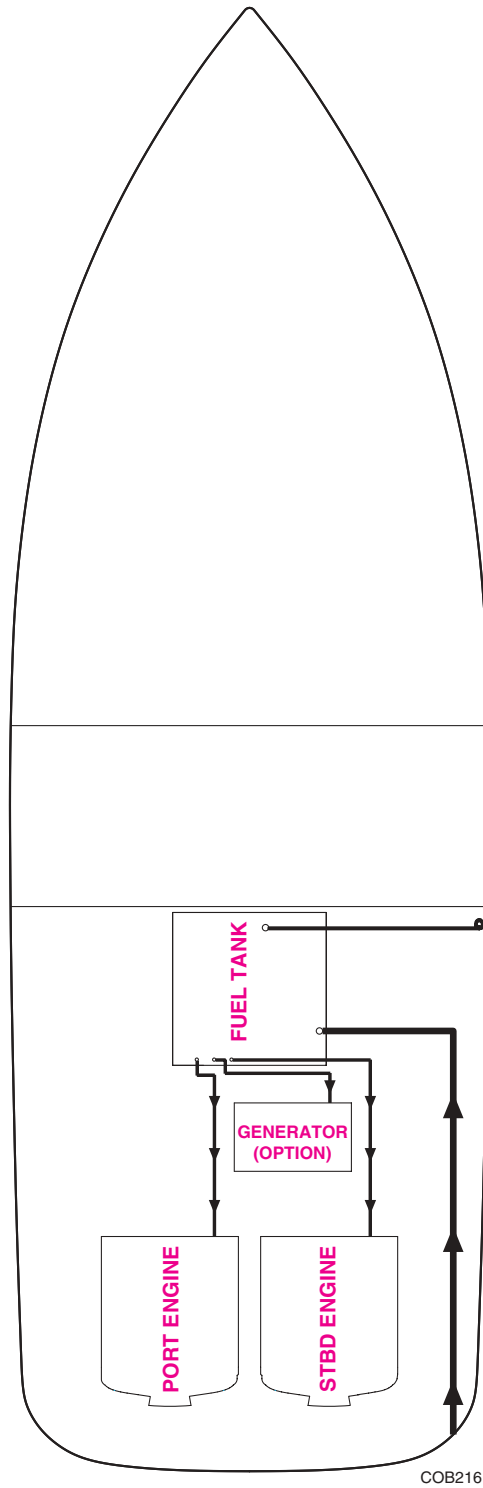



FRESH WATER PLUMBING

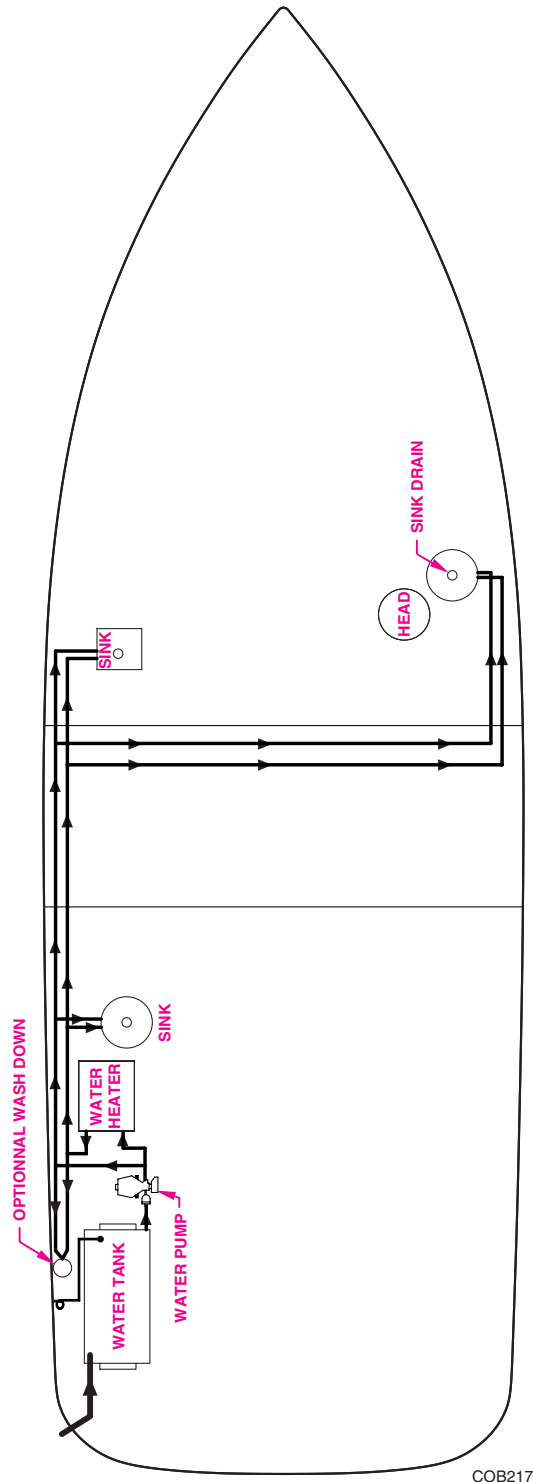

COB217



GRAY WATER PLUMBING

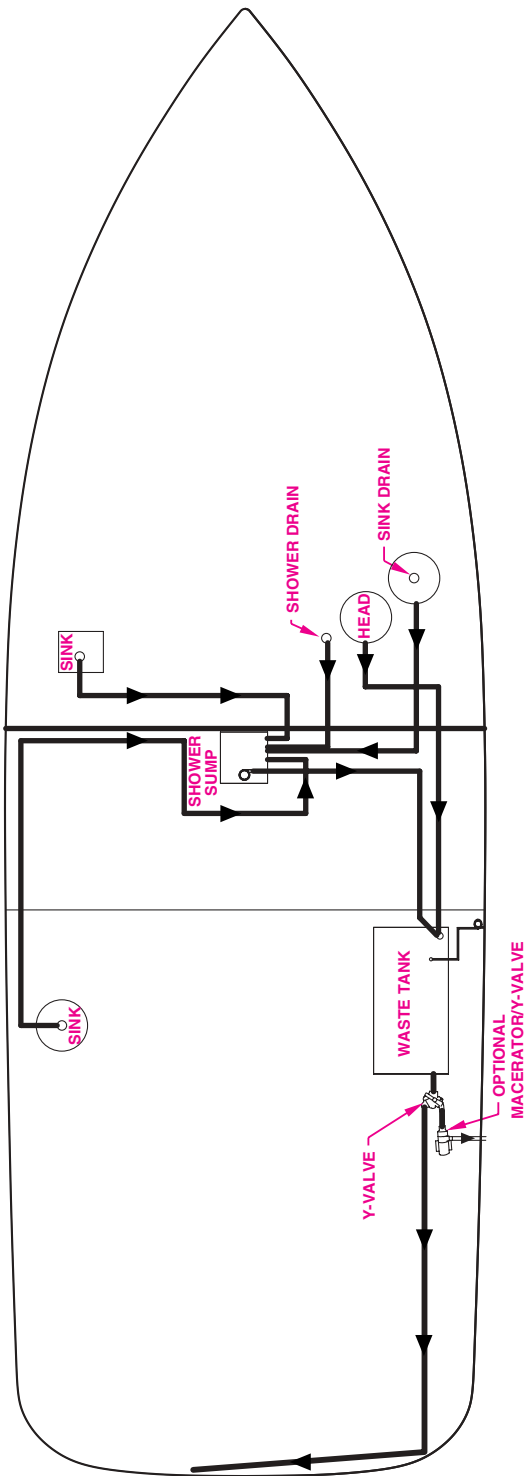

COB218



PROPELLER APPLICATION CHART

Model	Mfgr.	Engine	Drive	Fuel system	Std. Ratio	Optional Ratio	Php	Propeller Description	Mfgr. Part Number
293	MERC	6.2 MX MPI	BRAVO 1	MPI	1.65	1.65	320	21'S OFSH 4BL	48-825903A46/02A46
293	MERC	6.2 MX MPI	BRAVO 3	MPI	2.2	2.43	320	28'S B-3	48-823669A60/70A60
293	MERC	496 MAG MPI	BRAVO 1	MPI	1.5	1.65	375		
293	MERC	496 MAG MPI	BRAVO 3	MPI	1.81	2.2	375	22'S B-3	48-823663A60/64A60
293	MERC	496 MAG HO	BRAVO 1	MPI	1.5	1.65	425		
293	MERC	496 MAG HO	BRAVO 3	MPI	1.81	2.2	425	22'S B-3	48-823663A60/64A60
293	MERC	496 MAG HO-XZ	BRAVO 1	MPI			425		
293	MERC	TWIN 4.3 L MPI	ALPHA	MPI	1.62	1.81	220		
293	MERC	TWIN 4.3 L MPI	BRAVO 3	MPI	2.2	2.43	220		
293	MERC	TWIN 5.0 L	ALPHA	2 BBL	1.62	1.81	220		
293	MERC	TWIN 5.0 L	BRAVO 1	2 BBL	1.65	1.65	220		
293	MERC	TWIN 5.0 L	BRAVO 3	2 BBL	2.2	2.43	220	26'S B-3	48-823667A60/68A60
293	MERC	TWIN 5.7 L	ALPHA	2 BBL	1.47	1.62	250		
293	MERC	TWIN 5.7 L	BRAVO 1	2 BBL	1.65	1.65	250		
293	MERC	TWIN 5.7 L	BRAVO 3	2 BBL	2.2	2.43	250		
293	MERC	TWIN 5.0 L MPI	ALPHA	MPI	1.47	1.62	260		
293	MERC	TWIN 5.0 L MPI	BRAVO 1	MPI	1.65	1.65	260	19'S MIR	48-13701A46/00A46
293	MERC	TWIN 5.0 L MPI	BRAVO 3	MPI	2.2	2.43	260	28'S B-3	48-823669A60/70A60
293	MERC	TWIN 350 MAG MPI	ALPHA	MPI	1.47	1.62	300		
293	MERC	TWIN 350 MAG MPI	BRAVO 1	MPI	1.5	1.65	300	19'S OFSH 4BL	48-825901A46/00A46
293	MERC	TWIN 350 MAG MPI	BRAVO 3	MPI	2.0	2.2	300	26'S B-3	48-823667A60/68A60
293	MERC	TWIN 350 MAG MPI-HZN	BRAVO 3	MPI	2.0	2.2	300	26'S B-3	48-823667A60/68A60
293	MERC	TWIN 6.2 MX MPI	BRAVO 1	MPI	1.65	1.65	320		
293	MERC	TWIN 6.2 MX MPI	BRAVO 3	MPI	2.2	2.43	320	28'S B-3	48-823669A60/70A60
293	VOLVO	5.7 GXi	SX	TBI	1.51	1.51	320		
293	VOLVO	5.7 GXi	DP	TBI	1.95	1.95	320		
293	VOLVO	8.1 Gi	DP	MFI	1.78	1.78	375		
293	VOLVO	8.1 GXi	DP	MFI	1.78	1.78	420		
293	VOLVO	TWIN 5.0 GL	SX	2 BBL	1.6	1.79	220		
293	VOLVO	TWIN 5.0 GL	DP	2 BBL	1.95	2.32	220	F6'S	3851496
293	VOLVO	TWIN 4.3 GXi	SX	TBI	1.79	1.89	225		
293	VOLVO	TWIN 4.3 GXi	DP	TBI	2.32	2.32	225	F8'S	3851498
293	VOLVO	TWIN 5.7 GL	SX	2 BBL	1.51	1.6	260		
293	VOLVO	TWIN 5.7 GL	DP	2 BBL	1.95	2.32	260		
293	VOLVO	TWIN 5.0 GXi	SX	TBI	1.6	1.79	270		
293	VOLVO	TWIN 5.0 GXi	DP	TBI	1.95	2.32	270	F6'S	3851496
293	VOLVO	TWIN 5.7 Gi	SX	TBI	1.51	1.51	280		
293	VOLVO	TWIN 5.7 Gi	DP	TBI	1.95	1.95	280	F6'S	3851496
293	VOLVO	TWIN 5.7 GXi	SX	TBI	1.51	1.51	320		
293	VOLVO	TWIN 5.7 GXi	DP	TBI	1.95	1.95	320	F7'S	3851497



COBALT BOATS

P.O. Box 29 • Neodesha, KS 66757 • 800-468-5764 • www.cobaltboats.com